



February 18, 2019

California American Water
511 Forest Lodge Rd, Suite 100
Pacific Grove, CA 93950
ATTN: Donald Monette
Jay V. Drewry
Email: donald.monette@amwater.com
Jay.Drewry@amwater.com

Re: **Fitch Park ASR Wells 5 & 6; Responses to RFI dated 2-15-19**

Dear Mr. Drewry,

Thank you for your phone call on Friday afternoon. We are appreciative of your due diligence in evaluating Hal Hays Construction's proposal, and we hope to be the selected partner for this project.

Below, please find our official responses to the five (5) clarifications that you requested.

1. You requested HHCI to remove the "red-lined" PF-3 to remove the 30% contingency mark-up on each bid item.

HHCI Response: Summary Page PF-3 has been revised and now only includes base bid items excluding contingencies (Attachment 1).

2. You inquired about the \$20,000 "allowance for pipe and valves" under the "Exceptions" section of our original proposal.

HHCI Response: This was a clerical error. As discussed, the work associated with pipe and valves on this project will far exceed \$20,000. Please disregard this allowance and we have revised that page and it is attached (Attachment 2).

3. We looked at HHCI's bid item #68 "Complete control system...", you wanted to confirm

HHCI Response: Bid Item #68 – HHCI and Telstar held a very in-depth scoping meeting this morning, and both HHCI and Telstar are confident that we have sufficient monies allocated to this line item for the required work. If you would like to have a conference call to go over this in greater detail, both HHCI and Telstar will make ourselves available.

4. You requested a P&ID from our DOR (LSCE) for the Disinfection Building.

HHCI Response: Disinfection Building P&ID drawing - Drawings M-2 and P&ID I-1 are attached (Attachment 3a and 3b).

Proposal; and Proposer has not sought by collusion to obtain for itself any advantage over any other Proposer or over Owner.

P-4 CONTRACT PRICE

4.01 Proposer will complete the Work in accordance with the Contract Documents for the following price(s):

A. COST OF THE WORK

1. The Cost of all Work other than Unit Price Work shall be determined as provided in Paragraph 10.01 of the General Conditions, as revised or amended by the Supplementary Conditions and shall include the following amounts subject to increases or decreases for changes in Work as provided for in Article 8 of the Agreement

2. Lump Sum Fees

- a. Design Professional Services - Preliminary Design up to and Including Issuing of the Design Memorandum.

\$ 231,318.00

- b. Design Professional Services – Preliminary Design Completion through Final Design Phases.

\$ 393,240.00

- c. Design Professional Services – Construction/Operational Phase

\$ 335,412.00

- d. Pre-Construction Services during Design Phase

\$ 196,621.00

- e. **Total construction costs: includes Bid Form, Construction Supervision and Superintendence.**

\$ 4,768,205.00

- f. Cost of Bond Premiums (Based on construction estimate):

\$ 44,051.00

Premium unit Price \$ 8.00 / \$ 1,000.00

Range: \$ 4,000,000 to \$ 8,000,000

TOTAL LUMP SUM (a. + b. + c. + d. + e. + f.):

\$ 5,968,847.50

8. *The anticipated number and depth of all soil borings, if any, required after award of contract.*

For the geotechnical, our subconsultant Pacific Crest Engineering Inc. will explore, sample and classify surface and subsurface soils by drilling **4-6 exploratory borings** across the project area. Using Cone Penetrometer Test (CPT) soundings and in conjunction with subsurface borings, they will be able to evaluate the density and strength characteristics of the soil profile to the depths explored and obtain samples at selected depths within planned foundation areas.

At least one boring in the proximity of the proposed Percolation Basin shall be drilled and converted to an infiltration test hole and tested for infiltration characteristics. We have assumed one day of testing to be performed in accordance with the “Native Soil Assessment for Small Infiltration Based Stormwater Control Measures” guidelines prepared by Earth Systems Pacific for the Central Coast Low Impact Development Initiative. **The anticipated test depth is expected to range from approximately 3 to 5 feet below bottom of design pond elevation.**

The exploratory borings/soundings will range in **depth from 10 to 20 feet**, however, at least one CPT sounding will be extended to a depth of 50 feet to quantitatively address liquefaction and/or dynamic compaction potential beneath the project site. Soil samples will be obtained at selected depths within selected test borings. The test borings will be backfilled with soil cuttings upon completion of drilling.

9. *Specifics of any exceptions, which are taken to items requested in this document. If no exceptions are taken, it is not necessary to reiterate the information in the Scope of Services Required.*

The following items represent **HHCI’s exceptions and clarifications:**

- Permit Fees will be reimbursed by the owner
- Handling and disposal of any Hazardous materials is not included
- Contractor furnish and installs: transformer pad, primary and secondary conduits, meter main switchboard.
- PG&E furnish and installs: transformer, primary/secondary wires, utility meter
- Per addendum 5 Section 4, the generator can be max 80 horsepower / 480 KVa
- Landscaping shall consist of hydroseed of the areas outside of pavement and building areas to restore all disturbed earth to healthy, native, drought tolerant vegetation. The hydroseed mix and supplier shall be approved by the Owner. The hydroseed mix will be a native, drought-tolerant variety that does not require permanent irrigation nor mowing after the fescue is properly established. The hydroseed shall be either Heritage Mix, Native Ornamental Fine Fescue Mix, or California Bay Area Wildflower Mix, or others if directed by the Owner. Installation of hydroseed shall be completed by a Licensed Landscape Contractor. Installation shall include: weed eradication of native soil six weeks and three weeks prior hydroseed planting – required watering and chemicals to kills weeds; soil preparation and amendment using fertilizers; application of hydroseed mix; temporary watering and weed removal for at least three months, or longer, to establish the seed mix.

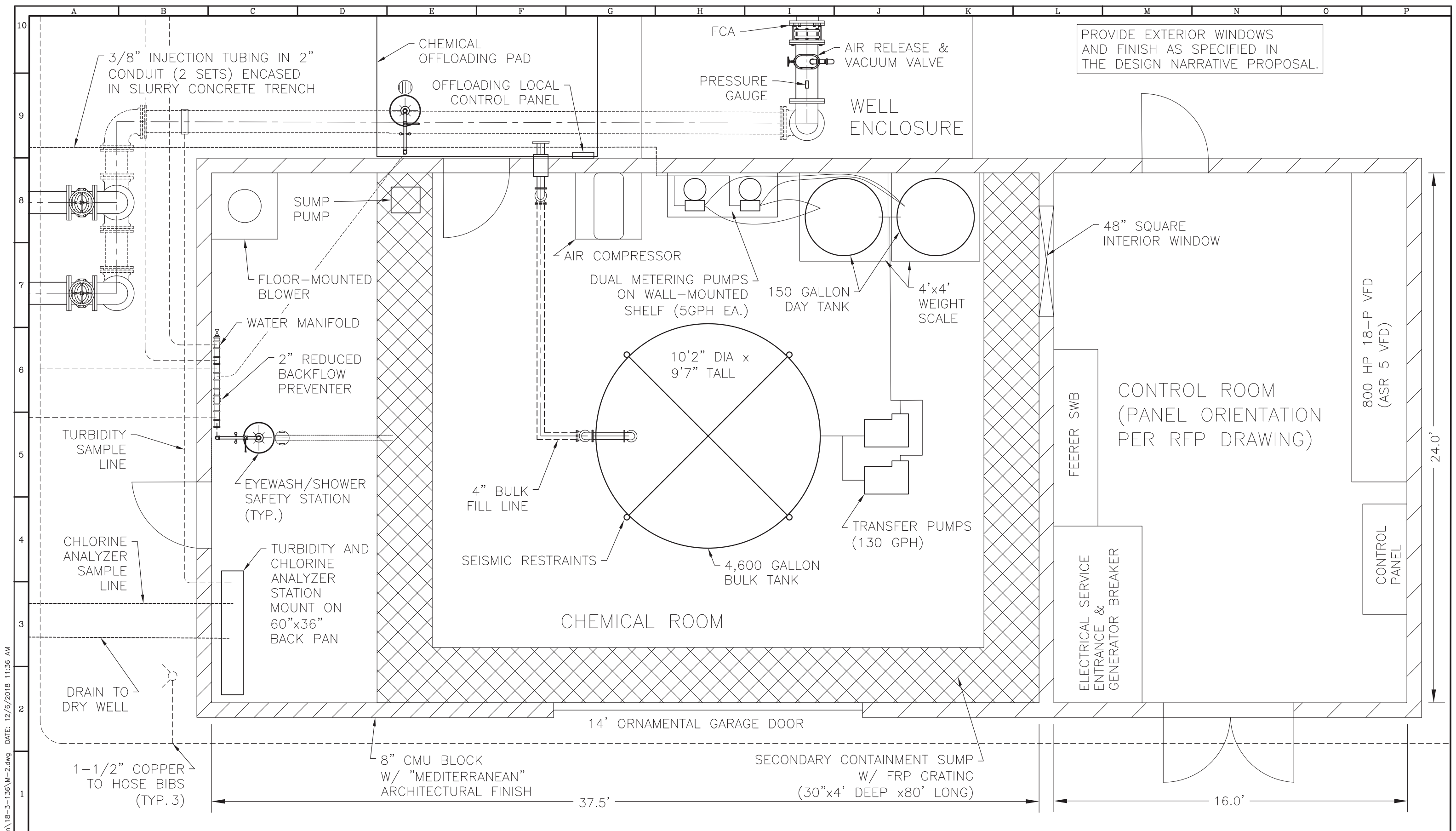

PROVIDE EXTERIOR WINDOWS AND FINISH AS SPECIFIED IN THE DESIGN NARRATIVE PROPOSAL.

CAD FILE: G:\Projects\Col-Am\18-3-136\M-2.dwg DATE: 12/6/2018 11:36 AM

DATE: DECEMBER 2018

LINE IS 2 INCHES AT FULL SIZE (IF NOT 2"-SCALE ACCORDINGLY)

FILE: M-2.DWG
 DRAWN: ABC/GRG
 DESIGNED: JMS
 CHECKED: WAG
 CHECKED:

NOT FOR CONSTRUCTION FOR PROPOSAL ONLY

NOT FOR CONSTRUCTION FOR PROPOSAL ONLY

Luhdorff & Scalmanini
 Consulting Engineers
 500 First Street
 Woodland, California

REVISIONS					
ZONE	REV.	DESCRIPTION	BY	DATE	APP.

CALIFORNIA AMERICAN WATER
FITCH PARK ASR WELLS 5 AND 6
 ABOVE GROUND FACILITIES

SUBMITTED: _____ DATE: _____
 SUBMITTAL APPROVED: _____ DATE: _____

CHEMICAL & ELECTRICAL BUILDING LAYOUT (ASR 5)

SCALE: 1"=4'

DRAWING NUMBER: **M-2**

SHEET NUMBER: **6 OF 7**

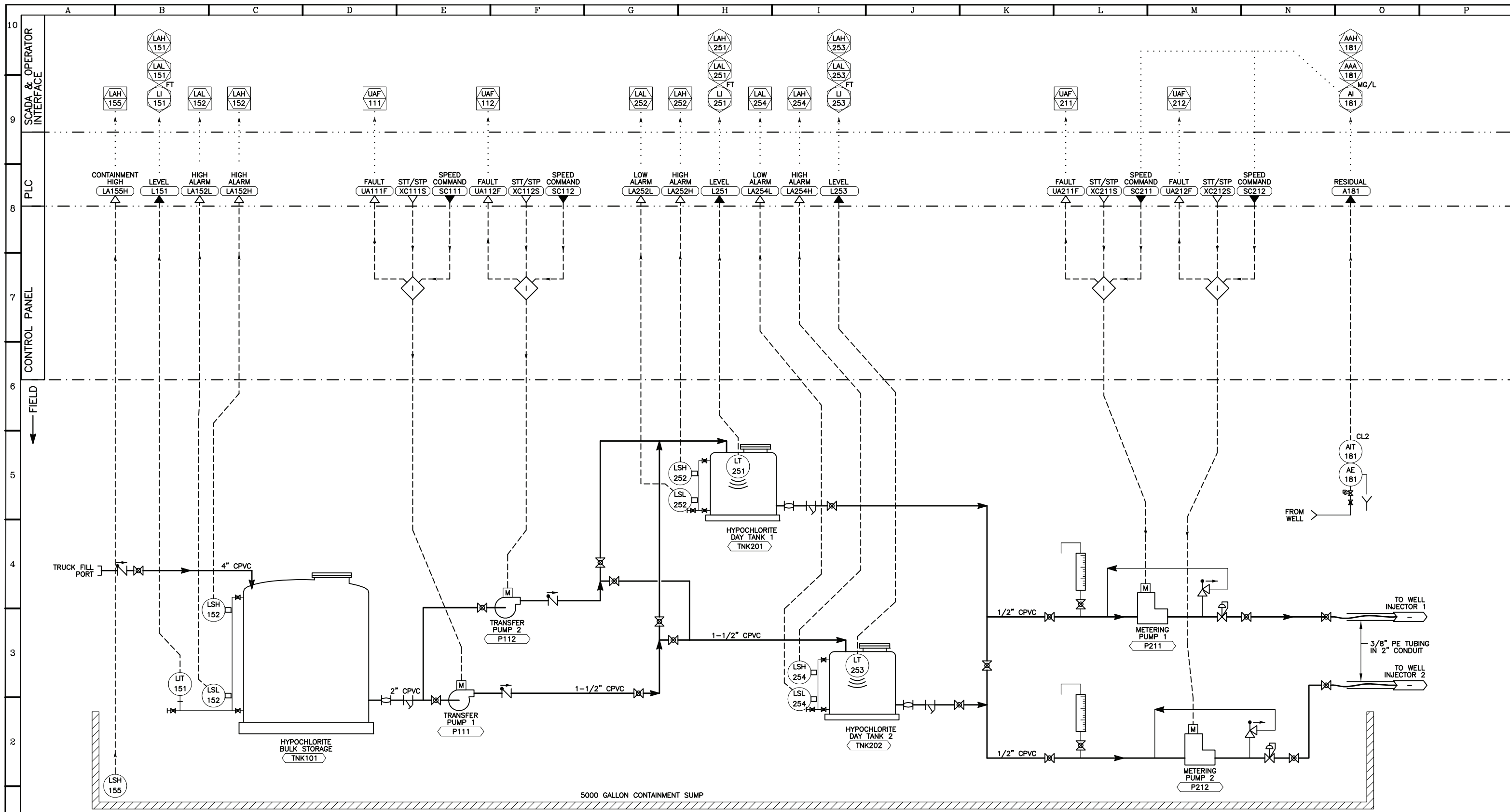

SODIUM HYPOCHLORITE P&ID

DATE: NOVEMBER 2018

FILE G-1.DWG
 DRAWN_NIK
 DESIGNED_TPF
 CHECKED_TPF
 CHECKED

LINE IS 2 INCHES
 AT FULL SIZE
 (IF NOT 2"-SCALE ACCORDINGLY)

NOT FOR
 CONSTRUCTION
 FOR
 PROPOSAL
 ONLY



REVISIONS					
ZONE	REV.	DESCRIPTION	BY	DATE	APP.

CALIFORNIA AMERICAN WATER
FITCH PARK ASR WELLS 5 AND 6
ABOVE GROUND FACILITIES

SUBMITTED: _____ DATE: _____
 SUBMITTAL APPROVED: _____ DATE: _____

INSTRUMENTATION
 HYPOCHLORITE SYSTEM
 P&ID

SCALE
 NO SCALE

DRAWING NUMBER
 1-1

SHEET NUMBER
 7 OF 7