

EXHIBIT 14-A

**Aquifer Storage and Recovery (ASR)
Management & Operations Agreement
between**

**California American Water
and**

Monterey Peninsula Water Management District

This Aquifer Storage and Recovery (ASR) Management & Operations Agreement (hereafter the "Agreement") between California American Water (hereafter "Cal-Am"), and Monterey Peninsula Water Management District (hereafter "Water Management District" or "District") is entered into as of the date last written below.

R E C I T A L S

WHEREAS, Cal-Am is an investor owned, public utility providing water service to the Monterey Peninsula; and

WHEREAS, the Water Management District is a public agency, authorized in 1977 by the California Legislature (Chapter 527 of the Statutes of 1977, as amended, found at West's Water Law Appendix, Section 118-1, et seq.). The voters of the Monterey Peninsula ratified creation of the Water Management District in June 1978. The District holds comprehensive authority to integrate management of the ground and surface water resources in the Monterey Peninsula area; and

WHEREAS, the Monterey Peninsula has an insufficient supply of water supplies available to it, and whereas this lack of water supply has been exacerbated by the effects of State Water Resources Control Board (SWRCB) Order WR 95-10, and the listing of the California red-legged frog and steelhead as threatened species under the federal Endangered Species Act; and

WHEREAS, Cal-Am and the Water Management District desire to define and clarify means by which they may cooperate and operate Aquifer Storage and Recovery facilities to augment the supply of water available to the Monterey Peninsula for the benefit of Cal-Am's rate payers, and the constituents of the Water Management District; and

WHEREAS, Cal-Am and the Water Management District have a mutual desire to expand and clarify the operations of existing Aquifer Storage and Recovery facilities, and to accelerate implementation future ASR facilities now planned as part of its Coastal Water Project;

WHEREAS, the California Department of Health Services has requested that an Agreement between Cal-Am and the Water Management District clarify and define responsibilities relating to the long-term operation of the Santa Margarita Well;

NOW, THEREFORE, BE IT RESOLVED the parties hereby enter into this Aquifer Storage and Recovery (ASR) Management & Operations Agreement as follows:

1. **Purpose.** This Agreement is intended to set forth general facts and assumptions concerning Aquifer Storage and Recovery (ASR) facilities and operations. This Agreement clarifies areas of joint effort and cooperation between the parties to facilitate present and future actions. The Parties agree to cooperate in order to optimize the creation and operation of the Existing ASR Facilities for present use and benefit to the ratepayers of Cal-Am, and the constituents of the Water Management District. The Parties agree to further cooperate to facilitate expansion of Existing ASR Facilities and to plan for the operation and use of Future ASR Facilities.
2. **Parties.** The sole parties to this Agreement are California American Water (hereafter "Cal-Am") and Monterey Peninsula Water Management District (hereafter "Water Management District" or "District").
3. **ASR Facilities.** Any reference in this Agreement to ASR Facilities shall mean all pumps, motors, piping and appurtenant ASR equipment located outside the points of connection to the Cal-Am water distribution system piping. This reference shall include land and rights of way in the City of Seaside and upon former Fort Ord lands relating to existing ASR facilities. The Water Management District shall solely and exclusively own all ASR Facilities, which ownership shall be inclusive of any rights pertaining to permits issued in relation to those ASR facilities. The parties agree to meet and confer, and engage in joint decision-making with respect to any capital improvement, facility modification or maintenance effort for the ASR Facilities.
4. **Associated ASR Facilities.** The term "Associated ASR Facilities" shall refer to all pipeline modifications, regulating station modifications and booster pump modifications installed within the Cal-Am water distribution system (including all points of connection, but excluding ASR Facilities as defined above, located outside the points of connection) and operated in connection with the Existing ASR. Cal-Am shall solely and exclusively own all Associated ASR Facilities, which ownership shall be inclusive of any rights pertaining to permits issued in relation to those Associated ASR facilities. The parties agree to meet and confer, and engage in joint decision-making with respect to any capital improvement, facility modification or maintenance effort for the Associated ASR Facilities.
5. **ASR Operator.** Cal-Am shall be the sole operator for all ASR Facilities and all Associated ASR Facilities, except as described in the Santa Margarita Test Injection Well (SMTIW) Aquifer Storage and Recovery (ASR) System, Operation and Maintenance Manual, a copy of which is attached to this Agreement as Exhibit A. Operations shall conform to all requirements set by the California Public Utilities Commission (CPUC) and the Department of Health Services (DHS) to meet the needs of the Cal-Am service area. Operations shall further conform to the water supply budget set by the Water Management District.
6. **ASR Operations.** References in this Agreement to ASR Operations shall mean activities undertaken in accord with the Santa Margarita Test Injection Well (SMTIW) Aquifer Storage and Recovery (ASR) System, Operation and Maintenance Manual, a copy of which is attached to this Agreement as Exhibit A. The Operation and Maintenance Manual may be modified from time to time by the written agreement of the Parties. Any such modification shall be made an exhibit to this Agreement. The term ASR Operations shall refer to both injection and recovery activities, shall refer to both Existing ASR and Future ASR, shall refer to both ASR Facilities and Associated ASR Facilities, and shall refer to both Future ASR Facilities and Future

Associated ASR Facilities, as those terms are defined by this Agreement. The Operations and Maintenance Manual shall define and designate the sole operator for the SMTIW. With respect to Future ASR, the Operation and Maintenance Manual shall be jointly devised, and modified from time to time by the parties.

7. **Existing ASR.** The term "Existing ASR" shall refer to the existing Santa Margarita Test Injection Well ASR facility (SMTIW), existing appurtenant on-site and off-site facilities, and related lands held by the Water Management District and Cal-Am. Existing ASR shall constitute both ASR Facilities and Associated ASR Facilities as those terms are defined in this Agreement. Existing ASR shall not include any facilities defined as Future ASR, except as may be provided by an addendum or amendment to this Agreement.
8. **Future ASR.** The term "Future ASR" shall refer to all planned Future ASR Facilities that will support future expansion of ASR Operations by the Water Management District and Cal-Am. Future ASR shall be comprised of both Future ASR Facilities and Future Associated ASR Facilities, as those terms may be defined in an amendment or addendum to this Agreement.
9. **Water Rights.** Cal-Am and the Water Management District agree to jointly cooperate and support each other's efforts to obtain and hold water rights from the SWRCB associated with ASR Operations. Cal-Am and the Water Management District further agree to jointly cooperate and support each other's efforts to extract and use water associated with ASR Operations. Cooperative efforts shall extend to both the existing ASR, ASR Facilities, Associated ASR Facilities, as well as Future ASR, Future ASR Facilities and Future Associated ASR Facilities. This Agreement, however, shall not affect or define the right or interest of either Party to store water in the Seaside Groundwater Basin.
10. **Permits.** Cal-Am and the Water Management District shall cooperate in the acquisition of all permits or approvals required for ASR Operations. The parties agree that they shall mutually cooperate and support each other's efforts pursuant to this paragraph, as may relate to Existing ASR and Future ASR, as well as to ASR Facilities and Associated ASR Facilities.
11. **Planning & Construction.** Cal-Am shall be the lead entity related to the planning and construction of all Associated ASR Facilities. The Water Management District shall be the lead entity related to the planning and construction of all ASR Facilities. The parties agree to jointly investigate means to minimize expenses of both ASR Facilities and Associated ASR Facilities relating to property acquisition, ownership, construction, and debt issuance.
12. **Long Term License & Franchise.** The Water Management District shall issue to Cal-Am a twenty (20) year term license to operate all ASR Facilities. The license shall recognize Cal-Am as the ASR Operator, with operational control over all ASR Facilities and all Associated ASR Facilities, provided those operations conform to the water supply budget set by the Water Management District. This license shall be in the form of a franchise, and it shall be irrevocable during its term, provided all Cal-Am is in compliance with all terms and conditions of this Agreement.
13. **Water Charges.** The Parties shall not charge or impose any fee or other expense upon each other, except as otherwise provided for in this Agreement, for the use of the ASR Facilities or the Associated ASR Facilities.

14. **Water Use.** All water produced from storage by either the ASR Facilities or the Associated ASR Facilities shall be held exclusively for the benefit of customers of Cal-Am.
15. **ASR Expenses.** All costs associated with operation of the ASR Facilities or the Associated ASR Facilities, including but not limited to costs of administration, operation, maintenance, repair, replacement, and insurance shall be borne by Cal-Am. Cal-Am shall further reimburse the Water Management District actual and necessary costs it may incur related to the ASR Facilities or the Associated ASR Facilities.
16. **Extraordinary Use of ASR Facilities.** Where the ASR Facilities are utilized by Cal-Am in lieu of operating other water production facilities, and when this operation does not relate to the recovery of water as part of the ASR Operations, then Cal-Am shall pay to the Water Management District for any costs it may incur with respect to the in lieu operation, including but not limited to costs of administration, operation, maintenance, repair and replacement.
17. **Effective Date.** This Agreement shall take effect on _____, 2005.
18. **Renewal Option.** To the extent ASR Facilities or Associated ASR Facilities are constructed having a usable life that exceeds the term of the license and franchise set by Section 12 above, Cal-Am shall have the option to extend and renew this Agreement to coincide with the remaining usable life of those ASR Facilities or Associated ASR Facilities, whichever has the longer remaining usable life. Notice of Cal-Am's intent to exercise this Renewal Option shall be communicated to the Water Management District, in writing, no less than one hundred eighty (180) days prior to the date referenced in Section 12. Cal-Am shall include a statement as to the remaining usable life of those ASR Facilities or Associated ASR Facilities in that notice. The Parties agree to meet and confer, and engage in joint decision-making with respect to determining any question regarding the remaining usable life of either the ASR Facilities or Associated ASR Facilities.
19. **Termination.** The term of this Agreement shall be co-terminus with the term of the License & Franchise set forth in accord with Paragraph 12.
20. **Limitation.** It is understood by the parties that all Agreements, obligations, debts and liabilities of Cal-Am do not constitute the Agreements, obligations, debts and/or liabilities of the Water Management District, its officers, agents and employees. Further, it is understood by the parties that all Agreements, obligations, debts and liabilities of the Water Management District do not constitute the Agreements, obligations, debts and/or liabilities of Cal-Am, its officers, agents and employees.
21. **Arbitration.** In case any disagreement, difference, or controversy shall arise between Cal-Am and the Water Management District with respect to any matter in relation to or arising out of or under this Agreement, whether as to the construction or operation thereof, or the respective rights and liabilities of Cal-Am or the Water Management District, and the parties cannot mutually agree as to the resolution thereof, then such disagreement, difference, or controversy shall be determined by arbitration under the commercial arbitration rules of the American Arbitration Association or upon such other rules as the Parties may agree. The submission to arbitration in accordance with the requirements of this section of any and all agreements, differences, or controversies that may arise hereunder is made a condition precedent to the institution of any action or appeal at law or in equity with respect to the controversy involved.

The award by the arbitrators shall have the same force and effect and may be filed and entered, as a judgment of the Superior Court of the State of California and shall be subject to appellate review upon the same terms and conditions as the law permits for judgments of Superior Courts. A "Prevailing Party" shall be determined in the Arbitration, and the prevailing party shall be entitled to reasonable attorney's fees and costs incurred, and accrued interest on any unpaid balance that may be due. Costs shall include the cost of any expert employed in the preparation or presentation of any evidence. All costs incurred and reasonable attorney fees shall be considered costs recoverable in that proceeding, and be included in any award.

22. **Entire Agreement.** This document represents the entire Agreement between the parties, and supersedes any prior written or oral negotiations and representations between the parties.

IN WITNESS WHEREOF, the parties hereto have executed this Agreement:

U/WMD/Gen 2005/ASR Management & Operations Agreement (4-8-05)- Draft #5(3)

**SANTA MARGARITA TEST INJECTION WELL (SMTIW)
AQUIFER STORAGE AND RECOVERY (ASR)
SYSTEM**

OPERATION AND MAINTENANCE MANUAL

CALIFORNIA AMERICAN WATER

APRIL 2005

**SANTA MARGARITA TEST INJECTION WELL (SMTIW)
AQUIFER STORAGE AND RECOVERY (ASR) SYSTEM**

OPERATING AND MAINTENANCE MANUAL

April 2005

CONTENTS

1.0 INTRODUCTION

I. Scope and Purpose.....1

2.0 SMTIW-ASR SYSTEM DESCRIPTION

I. Operation and Control Strategy2
 A. Injection
 B. Extraction

II. Primary Components3

III. Piping Schematic
 Extraction pumping to Ord Grove Treatment Plant.....4

IV. Valve Locations.....4

V. *Proposed* Extraction System Piping Schematic
 Extraction pumping to Hilby Tank.....4

VI. *Proposed* Plan for Pipeline Connection To Hilby Tank.....4

3.0 OPERATION

I. Injection Procedures.....5
 A. Startup/Shutdown
 B. Monitoring
 C. Alarm Conditions
 D. Emergency Procedures

II. Extraction Procedures-Existing Piping System to Ord Grove Plant.....7
 A. Startup/Shutdown
 B. Monitoring
 C. Alarm Conditions
 D. Emergency Procedures

III. <u>Proposed</u> Extraction Procedures –Future Pipeline to Hilby Tank.....	8
A. Startup/Shutdown	
B. Monitoring	
C. Alarm Conditions	
D. Emergency Procedures	

4.0 MAINTENANCE.

I. Daily/ Weekly.....	10
A. Injection System	
B. Extraction System	
II. Periodic.....	10
A. Injection System	
B. Extraction System	

5.0 WELL AND AQUIFER PERFORMANCE MONITORING AND MAINTENANCE

I. ASR System Performance Evaluation.....	11
A. Assessment of DBP occurrence and fate in aquifer.	
B. Evaluation/adjustment of long term injection rates and backflushing frequency.	
II. Well Screen Maintenance.....	11
III. Well Backflushing and Redevelopment.....	11

FIGURES- (FOLLOWING PAGE 4)

- Figure-1 Piping Schematic for Existing SMTIW-ASR System
- Figure-2 Valve Locations for Existing SMTIW-ASR System (Ord Grove Ave.)
- Figure-3 Valve Locations for Existing SMTIW-ASR System (General Jim Moore Blvd.)
- Figure-4 Piping Schematic for Proposed Hilby Tank Connection

TABLES

Table-1 Primary Components for the SMTIW-ASR System.....	6
Table-2 Valve Identification and Sequencing for ASR Operations.....	6

APPENDIX A

Contact Phone Numbers

APPENDIX B

Project Description for Proposed Hilby Tank Pipeline Connection

**SANTA MARGARITA TEST INJECTION WELL (SMTIW)
AQUIFER STORAGE AND RECOVERY (ASR) SYSTEM**

OPERATING AND MAINTENANCE MANUAL

April 2005

1.0 INTRODUCTION

The Santa Margarita Test Injection Well (SMTIW) was designed and constructed to serve as part of an Aquifer Storage and Recovery (ASR) system. During the rainy season when treated water is available from Carmel River sources, potable water from the California American Water (CAW) distribution system will be injected into the well. During the summer and fall when the Monterey area is typically relying entirely on groundwater withdrawals, the well will be available as a source of potable water that can be pumped directly to the distribution system under certain monitoring protocols. Operation of the ASR system is a joint effort between the Monterey Peninsula Water Management District (MPWMD) and CAW, under permitting authority of the California Department of Health Services (DHS).

Scope, and Purpose

On November 30, 2004, CAW submitted an Operations Plan for the Santa Margarita Well to DHS along with other requested information. Following that submittal, a consensus was reached between MPWMD and CAW staff that a more procedural document was needed. As a result, the following document was prepared to be a guide and reference for CAW operators in their daily operation of the SMTIW injection and extraction systems. It contains only information and protocols specific to the SMTIW-ASR system, and its focus is only on the information that may be needed by CAW operators in the field. Though MPWMD plays a critical role in the operation of the system, this document only delineates those areas of responsibility and does not provide additional detail.

This manual is intended to be a working document that will be continually updated as the system is expanded or modified, or to reflect changes in operational procedures or areas of responsibility.

2.0 SMTIW-ASR SYSTEM DESCRIPTION

I. Operation and Control Strategy

During the rainy season, typically December through May, the SMTIW will be operated in Injection mode to store surplus Carmel River Aquifer water for future use. During the dry season, typically June through October, the SMTIW will be operated in Extraction mode and be used as a water supply source for the Monterey system.

Piping currently connects the SMTIW to the CAW distribution system at the Luzern Well site and the Paralta Well site. Control wiring currently exists between the SMTIW panel and the panel at the Paralta well site. (When constructed, a proposed piping connection will also connect the SMTIW to the CAW distribution system at the Hilby Tank.

A. Injection

Once distribution system valves are set properly, potable water is injected into the SMTIW from the CAW distribution system via the ASR Booster pump located at the Luzern Well. The pump is operated manually from a switch at the Luzern Well Control Panel.

B. Extraction

When the SMTIW is used as a supply source, the SMTIW pump is under automatic control by the PLC settings on the Paralta Well panel. The SMTIW is only used when the Paralta Well is shut down, and vice versa, so the SMTIW is under exactly the same ON/OFF control logic as the Paralta Well.

Water from the SMTIW is pumped to the Ord Grove Ozone Treatment plant for removal of any hydrogen sulfide and final chlorination prior to distribution. A variable frequency drive (VFD) on the SMTIW well ensures that the pumped flow from the well does not exceed the Ord Grove Treatment Plant capacity. The VFD is controlled manually at the SMTIW control panel.

II. Primary Components

Table-1 Primary Components for the SMTIW-ASR System.

A. ASR Booster Pump	
Location	Luzern Well Site
Type	Standard close-coupled Centrifugal
Motor Size	100 HP
Motor Drive	Single Speed
Power Supply	480 V, 3 PH
Backup Power	Portable Generator
Rated Capacity	2,000 GPM @ approx. 150 ft TDH
Controls	Manual, Switch at Luzern Panel
Discharge Piping Diameter, Luzern Well to SMTIW	12 inch
Approximate Injection Test Flow (2004 season)	Approximately 600-1,450 gpm
Design Injection Flow (best long-term performance)	1,000 gpm
Backflushing Frequency	weekly
B. SMTIW Pump	
Location	SMTIW site
Type	Vertical Turbine
Motor Size	400 HP
Motor Drive	Variable Frequency Drive (VFD) Adjusted to match pump output to Ord Grove Treatment Plant Output
Power Supply	480 V, 3 PH
Backup Power	Off-site portable generator. No backup power facilities on-site.
Rated Capacity	2,600 gpm @ approx. 425 ft TDH
Average Extraction Flow (2004 season)	Approximately 1,570 gpm
ON/OFF Control	Automatic (PLC)- switch at Paralta Panel
VFD	Manual rheostat at SMTIW control panel.
Discharge Piping Diameter	12 inch
Typical Backflush Flow (2004 season)	1,700- 2,600 gpm

III. Existing Piping Schematic
Extraction pumping to Ord Grove Treatment Plant
(Please refer to Figure-1.)

IV. Existing Valve Locations
(Please refer to Figure-2 and Figure-3.)

V. Proposed Extraction System Piping Schematic (Extraction pumping to Hilby Tank)
(Please refer to Figure-4.)

VI. Proposed Plan for Pipeline Connection To Hilby Tank
(Please refer to Appendix B for description of proposed project.)

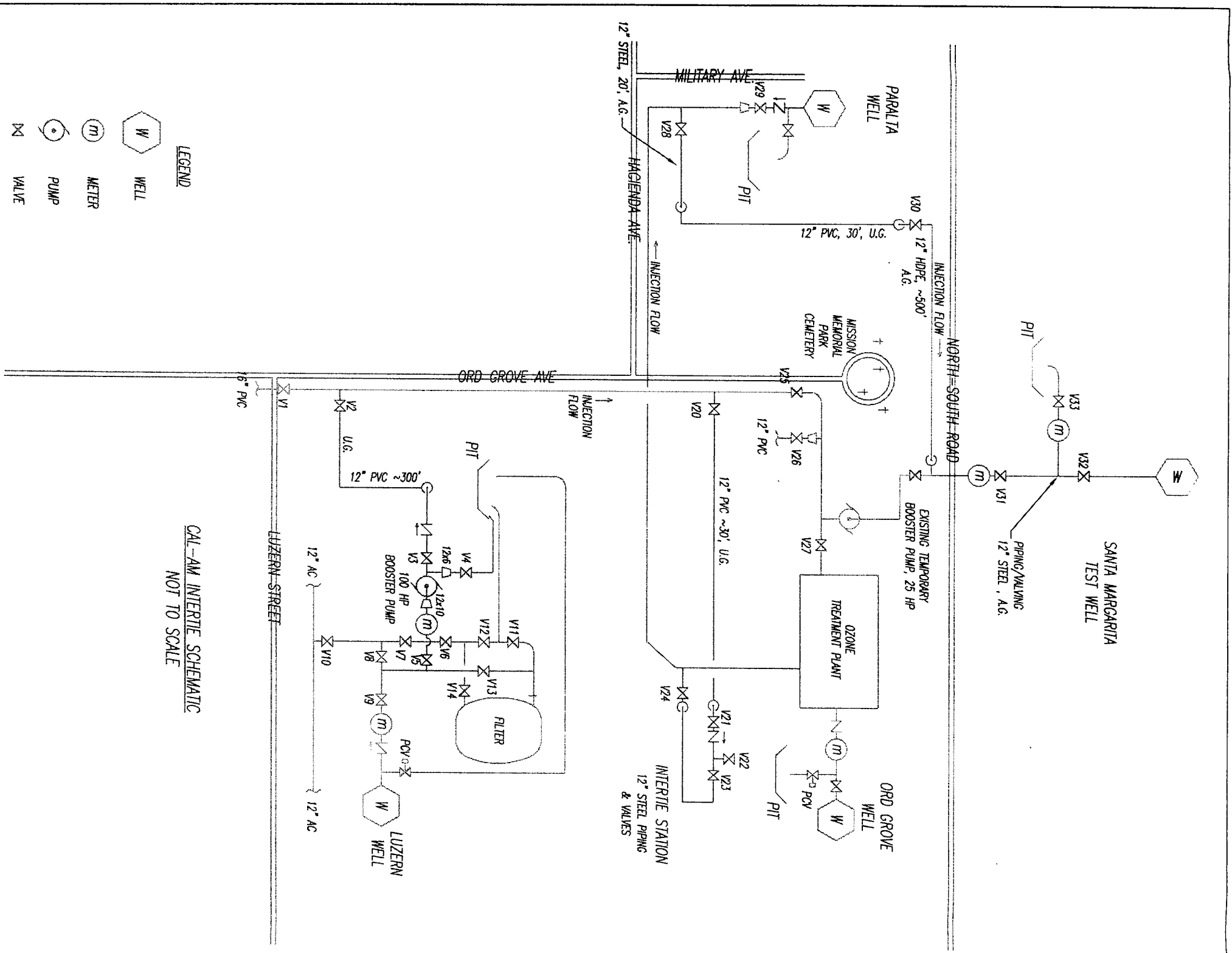

CAL-AM INTERTIE SCHEMATIC
NOT TO SCALE

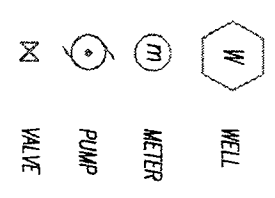

VALVE IDENTIFICATION & SEQUENCING FOR ASR OPERATIONS

VALVE NO.	TYPE	CONDITION	INSTALLATION	LOCATION/FACILITY	NORMAL CAL-AM POSITION (SUMMER)	ASR POSITION	ASR STARTUP SEQUENCE	ASR SHUTDOWN SEQUENCE
V1	BF	E	U	Ord Grove/Luzern	0	X	5	19
V2	G	N	U	Ord Grove/Luzern	X	0	21	12
V3	OSY	N	A	Luzern	X	0	23	13
V4	OSY	N	A	Luzern	X	0/X	25*	1*
V5	G	N	U	Luzern	X	0	22	14
V6	G	E	A	Luzern	0	X	10	15
V7	G	E	A	Luzern	0	0	-	-
V8	G	E	A	Luzern	X	X	-	-
V9	G	E	A	Luzern	0	X	6	16
V10	G	E	U	Luzern	0	0	-	-
V11	G	E	A	Luzern	X/0	X	8	-
V12	G	E	A	Luzern	0	X	9	-
V13	G	E	A	Luzern	0	X	7	17
V14	G	E	A	Luzern	0	0	11	18
V20	G	N	U	Ord Grove/Hacienda	X	0	16	7
V21	OSY	N	A	Hacienda Intertie	X	0	17	8
V22	OSY	N	A	Hacienda Intertie	X	X	18	11
V23	OSY	N	A	Hacienda Intertie	X	0	19	10
V24	G	N	U	Hacienda Intertie	X	0	20	9
V25	BF	E	U	Ord Grove/Cemetery	0	X	1	20
V26	G	E	U	Ord Grove/Cemetery	0	X	2	21
V27	G	E	U	03 Treatment Plant	0	X	3	22
V28	G	N	A	Paralta	X	0	15	6
V29	BF	E	A	Paralta	0	X	4	-
V30	G	N	U	Paralta	0	0	14	5
V31	G	N	A	SMW	X	0	13	4
V32	G	N	A	SMW	X	X/0	-	3
V33	G	N	A	SMW	X	0/X	12	-
PUMP	-	-	A	Luzern	OFF	ON*	24*	2*

TYPE: BF=BUZZERFLY, G=GATE, OSY=OUTSIDE STEM & YOKE
 CONDITION: E=EXISTING, N=NEW
 INSTALLATION: A=ABOVEGROUND, U=UNDERGROUND
 VALVE POSITION: 0=OPEN, X=CLOSED

OWNER: SMTIW
 DESIGNED: [Signature]
 DRAWN: [Signature]

padre
 REGISTERED PROFESSIONAL ENGINEER
 No. 51981
 State of California
 REGISTERED PROFESSIONAL ENGINEER
 No. 51981
 State of California

PROJECT NO.: [Blank]
 SCALE: [Blank]

Figure-1
Piping Schematic for Existing SMTIW-ASR System

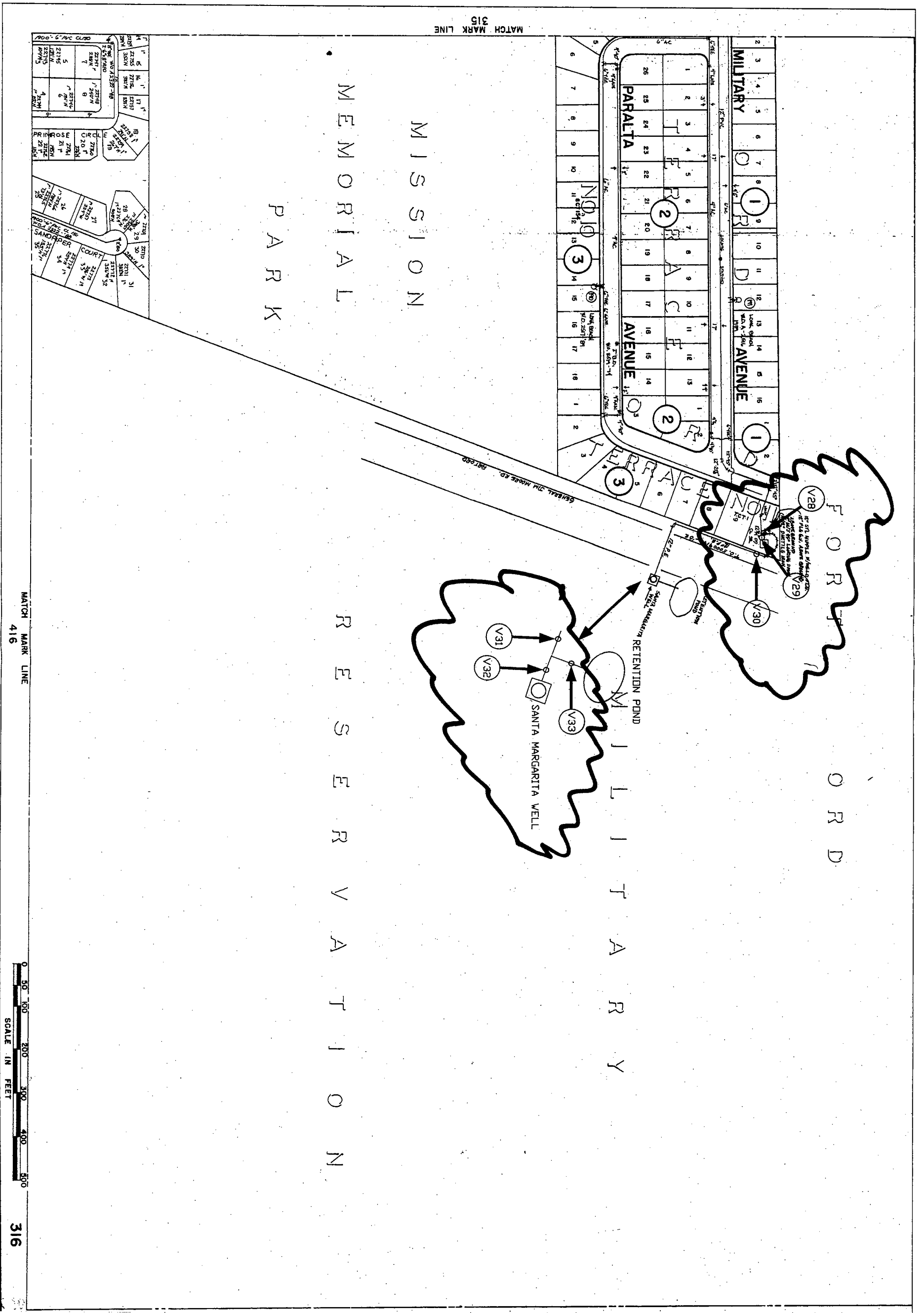

Figure-3
Valve Locations for Existing SMTIW-ASR System

3.0 OPERATION

I. INJECTION PROCEDURES

Injection operation is when potable water from the CAW distribution system is pumped back into the SMTIW. This typically happens during the period from December through May.

A. Startup/Shutdown

All startup and shutdown shall be coordinated with MPWMD. After initial startup, temporary shutdown and restart will be required periodically (approximately weekly) as needed for backflushing of the well. This will be also be directed by MPWMD.

MPWMD contact - Joe Oliver , phone 831-658-5640, cell 915-9031.

The specific startup sequence is as follows:

a.) Startup:

1. MPWMD notifies CAW that it is ready to proceed with injection operations.
2. CAW operators check valves V-1 through V-30 as shown in Table-1 (below) and verify that they are in the "ASR Position". A piping schematic and a map showing the location of each valve are provided in the previous section (Chapter 2).
3. MPWMD adjusts V31, V32, and V33 as required. Operation of these valves will not be the responsibility of CAW operators.
4. Once all valves are set correctly, a CAW operator starts the ASR Booster pump from the control panel located at the Luzern Well site.

b.) Shutdown (reverse of startup sequence):

1. MPWMD notifies CAW that it intends to stop injection operations.
2. A CAW operator shuts down the ASR Booster pump from the control panel located at the Luzern Well site.
3. CAW operators re-position valves V-1 through V-30 as shown in Table-1 (below) and verify that they are in the "Normal CAW Position (Summer)". A piping schematic and a map showing the location of each valve are provided in the previous section (Chapter 2).
4. MPWMD will adjust V31, V32, and V33 as required.

B. Monitoring

There are no additional monitoring responsibilities for CAW operators for the Injection operation. MPWMD may continue to evaluate water quality of injected water as part of the ongoing testing program.

C. Alarm Conditions

There are no additional alarm conditions. Notify MPWMD of booster pump failure. Repair or replace pump as necessary.

D. Emergency Procedures

General CAW emergency protocols apply. **Call 911 for Medical, Fire, or Law Enforcement Emergency.** Follow CAW standard procedures for main breaks or other system emergencies. Notify MPWMD of any emergency that would affect injection operations.

TABLE-2 VALVE IDENTIFICATION & SEQUENCING FOR ASR OPERATIONS

VALVE NO.	TYPE	CONDITION	INSTALLATION	LOCATION/FACILITY	EXTRACTION	INJECTION		
					NORMAL CAW POSTION (SUMMER)	ASR POSTION	ASR STARTUP SEQUENCE	ASR SHUTDOWN SEQUENCE
V1	BF	E	U	Ord Grove@Luzern	0	X	5	19
V2	G	N	U	Ord Grove@Luzern	X	0	21	12
V3	OSY	N	A	Luzern	X	0	23	13
V4	OSY	N	A	Luzern	X	0/X	25*	1*
V5	G	N	U	Luzern	X	0	22	14
V6	G	E	A	Luzern	0	X	10	15
V7	G	E	A	Luzern	0	0	-	-
V8	G	E	A	Luzern	X	X	-	-
V9	G	E	A	Luzern	0	X	6	16
V10	G	E	U	Luzern	0	0	-	-
V11	G	E	A	Luzern	X/0	X	8	-
V12	G	E	A	Luzern	X/0	X	9	-
V13	G	E	A	Luzern	0	X	7	17
V14	G	E	A	Luzern	0	0	11	18
V20	G	N	U	Ord Grove@Hacienda	X	0	16	7
V21	OSY	N	A	Hacienda Intertie	X	0	17	8
V22	OSY	N	A	Hacienda Intertie	X	X	18	11
V23	OSY	N	A	Hacienda Intertie	X	0	19	10
V24	G	N	U	Hacienda Intertie	X	0	20	9
V25	BF	E	U	Ord Grove@Cemetery	0	X	1	20
V26	G	E	U	Ord Grove@Cemetery	0	X	2	21
V27	G	E	U	O3 Treatment Plant	0	X	3	22
V28	G	N	A	Paralta	X	0	15	6
V29	BF	E	A	Paralta	0	X	4	-
V30	G	N	U	Paralta	0	0	14	5
V31	G	N	A	SMW	X	0	13	4
V32	G	N	A	SMW	X	X/0	-	3
V33	G	N	A	SMW	X	0/X	12	-
PUMP	-	-	A	Luzern	OFF	ON*	24*	2*

MPWIND ONLY

MPWIND ONLY

TYPE: BF=BUTTERFLY, G=GATE, OSY=OUTSIDE STEM & YOKE

CONDITION: E=EXISTING, N=NEW

INSTALLATION: A=ABOVEGROUND, U=UNDERGROUND

VALVE POSTION: 0=OPEN, X=CLOSED

**PLEASE REFER TO PREVIOUS SECTION FOR PIPING SCHEMATIC AND MAP SHOWING VALVE LOCATIONS

II. EXTRACTION PROCEDURES -Existing system using Ord Grove Treatment Plant
Extraction is when the SMTIW is used as a water source for the Monterey system. This occurs during the dry season, typically June through October.

A. Startup/Shutdown

All startup and shutdown shall be coordinated with MPWMD.

MPWMD contact - Joe Oliver , phone 831-658-5640, cell 915-9031.

The specific startup and shutdown sequences are as follows:

a.) Startup:

1. MPWMD notifies CAW that it may begin pumping from the SMTIW.
2. CAW operators check valves V-1 through V-30 as shown in Table-1 (below) and verify that they are in the "Normal CAW Position". A piping schematic and a map showing the location of each valve are provided in the previous section (Chapter 2).
3. MPWMD will adjust V31, V32, and V33 as required. Operation of these valves will not be the responsibility of CAW operators.
4. At the Paralta Well site, a CAW operator closes the discharge valve on the Paralta Well and opens the valve on the SMTIW pipe connecting to the CAW distribution system.
5. CAW operators will rewire contacts in Paralta Well Panel so that the SMTIW can be operated remotely in AUTO mode from the Paralta Well Panel using the same control logic as the Paralta Well.
6. Coordinate with MPWMD to set the VFD on the SMTIW pump to match current Ord Grove Treatment Plant output.
7. After the VFD on the SMTIW pump has been adjusted satisfactorily, a CAW operator places the SMTIW starter switch in the AUTO position at the Paralta Well Panel

b.) Shutdown (reverse of startup sequence):

1. MPWMD notifies CAW that it must stop pumping from the SMTIW, or alternatively, CAW decides to discontinue pumping based on system demand conditions.
2. A CAW operator shuts down the SMTIW pump at the Paralta Well control panel.
3. At the Paralta Well site, a CAW operator opens the valve on the Paralta Well discharge and closes the valve on the SMTIW piping connection to the distribution system
4. A CAW operator re-configures the connections in the Paralta Well control panel so that the Paralta Well pump will be under control of the PLC.
5. A CAW operator places the Paralta Well starter switch in the AUTO position at the Paralta Well Panel.

B. Monitoring

Since the SMTIW will be operated as a supply well in place of the Paralta Well, all routine water quality monitoring of the finished water prior to distribution will be in accordance with the existing Ord Grove Treatment Plant operating permit with the Department of Health Services (DHS). There are no additional routine monitoring responsibilities for CAW operators for the SMTIW Extraction operation.

Additional monitoring for Disinfection Byproducts (DBPs) is required as part of the DHS operating permit for the SMTIW. Sample collection, analysis, and submittal will continue to be under the direction of Leslie Jordan, CAW Water Quality Supervisor (phone 646-3258). CAW operators will not be routinely involved in sample collection for DBPs, unless directed by Leslie Jordan otherwise.

In addition, MPWMD may continue to take samples to evaluate water quality of the extracted water as part of its ongoing testing program.

C. Alarm Conditions

Alarm conditions for disinfectant residual or pump failure are the same as for the Ord Grove Treatment Plant.

There are no other alarm conditions.

Notify MPWMD of well pump failure.

D. Emergency Procedures

General CAW emergency protocols apply.

Call 911 for Medical, Fire, or Law Enforcement Emergency.

Follow CAW standard procedures for leaks, equipment failure, or loss of power.

III. PROPOSED EXTRACTION PROCEDURES -Future connection to Hilby Tank *(To be finalized in accordance with as-built configuration)*

A. Startup/Shutdown

The proposed procedures will be the same as the current procedures, EXCEPT for the following:

- 1. Instead of operating the valve at the intertie to the Paralta Well, operators will operate a valve on the Hilby Pipeline.*
- 2. The PLC On/Off controls will be configured to respond to tank level at the Hilby Tank and to interlock the hypochlorite feed pump.*
- 3. To avoid on/off pump cycling, the PLC controls will also be programmed to provide automatic adjustment of the VFD on the SMTIW pump via input from the Hilby tank sensor.*

B. Monitoring

The proposed procedures will be the same as the current procedures, EXCEPT for the following:

- 1. When required, distribution system samples will be taken at the outlet to Hilby Tank.*

C. Alarm Conditions

The proposed configuration will have the following Alarm conditions that will shut down the SMTIW pump:

- 1. Tank High Level, Hilby Tank.*
- 2. SMTIW Hypochlorite Feed Pump Fail*

D. Emergency Procedures

The proposed procedures will be the same as the current procedures, EXCEPT for the following:

- 1. If distribution system monitoring at the outlet to Hilby Tank detects DBPs in excess of the MCLs, the SMTIW pump will be shut down and the system will be reconfigured for Extraction through the Ord Grove Treatment Plant, as described in Part II.*

4.0 MAINTENANCE

The majority of the maintenance procedures for the SMTIW-ASR System are covered under routine maintenance practices for the Paralta Well, or in the Operation and Maintenance Manual for the Ord Grove Treatment Plant. Listed here are only the additional responsibilities that arise from the SMTIW-ASR system.

I. Daily

A. Injection System

1. Visually inspect all above-ground piping and valves for leaks or damage and repair if necessary.
2. Inspect ASR Booster Pump seals, adapters, and connections for leaks.
3. Watch and listen to ASR Booster Pump and note any overheating, excess vibration, or unusual noises indicating bearing wear. Schedule repairs as required.

B. Extraction System

1. Visually inspect all above-ground piping and valves for leaks or damage, and schedule repairs as necessary. Notify MPWMD of any abnormal conditions observed at the SMTIW wellhead.
2. Watch and listen to SMTIW Pump Motor and note any overheating, excess vibration, or unusual noises indicating bearing wear. Notify MPWMD of any abnormal conditions.
3. Inspect control panel for any signs of damage. Notify MPWMD of any abnormal conditions.
- 4.

Proposed Configuration Only:

5. *Verify operation of hypochlorite feed system.*
6. *Verify chemical metering pump discharge rate.*
7. *Verify that the chlorine residual is within range.*
8. *Check supply of hypochlorite solution in storage tank. Order more as needed.*
9. *Check entire feed system for leaks or spills and clean-up as necessary.*

II. Periodic

A. Injection System

1. Thoroughly clean and inspect ASR Booster Pump and Motor at end of season and replace parts according to manufacturers maintenance schedule.

B. Extraction System

1. Periodic / annual maintenance of the SMTIW Pump and motor will be coordinated by MPWMD. CAW operators will not routinely be involved.
- 2.

Proposed Configuration Only:

3. *On a monthly basis, CAW operator shall visually inspect above-ground Hilby Pipeline for any signs of leaks, damage, or vandalism.*

5.0 WELL AND AQUIFER PERFORMANCE MONITORING AND MAINTENANCE

CAW Operators will have no additional routine tasks in this area.

I. ASR System Performance Evaluation

Ongoing evaluation of the ASR system performance will be conducted by the MPWMD with input from the CAW Engineering staff and outside consultants. CAW operators will have no direct involvement in this process.

A. Assessment of DBP occurrence and fate in aquifer.

MPWMD and its consultants will coordinate and direct as necessary. CAW will collect and submit DBP samples from the distribution system in accordance with DHS requirements.

B. Evaluation/adjustment of long term injection rates and backflushing frequency.

MPWMD and its consultants will coordinate and direct as necessary.

II. Well Screen Maintenance

MPWMD and its consultants will coordinate and direct as necessary.

III. Well Backflushing and Redevelopment

MPWMD and its consultants will coordinate and direct as necessary.

APPENDIX A.

**SANTA MARGARITA TEST INJECTION WELL
OPERATION AND MAINTENANCE**

CONTACT PHONE NUMBERS

FOR MEDICAL OR LAW ENFORCEMENT EMERGENCY, DIAL 911

Agency/Person	Title	Phone
Monterey Peninsula Water Management District (MPWMD)		
Joe Oliver	Water Resources Manager	658-5640; cell 915- 9031
Tom Lindberg	Associate Hydrologist	958-5642; cell 915- 5978
California American Water Operators		
Craig Evans	Production Foreman	646-3250; cell 236-7497
Mike Magretto	Operations Supervisor	646-3220; cell 236-7530
Dave Schroeder	Production Foreman	646-3254; cell 236-7498
Other Involved Personnel		
Aman Gonzalez	CAW Operations Engineer	646-3261; cell 236-6828
Leslie Jordan	CAW Water Quality Supervisor	646-3258; cell 236-7533
David Norris	CAW Operations Engineering Consultant	659-9230
Jan Sweigert	Engineer, Department of Health Services	655-6939
Steve Tanner	Engineering Consultant, Padre Associates	805-683-1233

APPENDIX B.

PROJECT DESCRIPTION FOR PROPOSED HILBY TANK PIPELINE CONNECTION

a) SMITW Intertie Pipeline Route Design (Attachment A), prepared by Padre Associates, dated September 21, 2004.

b) SMITW Intertie Pipeline Route Design (Figures 1-3), prepared by Padre Associates, dated August, 2004.

c) Santa Margarita Pipeline Project (Sheets 1 and 2), prepared by CAW dated October 2004.

**ATTACHMENT A
SMITW INTERTIE PIPELINE ROUTE DESIGN**

Station	Pipeline Location (ft. east of fence)	Distance G.I.F. to E.P. (feet)	Comments
1+00	3	70	Begin 16" HDPE, SDR 13.5 w.l. Replace exist 12" tee with 12" cross
			Install 12x16 reducer (C.I., FxF) on south and Air Vac valve
			Install 16" Flg. Adaptor on w.l. (see Figure 2)
1+95	3		Trim branches on 14' pine (green paint spot on trunk)
2+15	3-6		Trim branches on 12" pine (tree row is 12' E of c.l.f.)
3+45	3-6		(Opposite abandoned mausoleum box)
4+00	3-6		Trim branches on 12" pine
4+20	3-6	75	(Opposite roadway in cemetery)
7+50	3-6		Trim juniper branches
8+40	3-6		Trim juniper branches - 20" tree with green and yellow spot
9+00	3-6		Trim juniper branches
9+25	3-6	80	(End of cemetery property)
10+00	6-18		Start transition of w.l. to east side of tree row
10+75	35-40		Transition complete to east side of trees
11+00	35-40		(Grade of w.l. route begins to drop below elevation of GJM Boulevard)
11+25	35-40		(Opposite wood power pole) Possible pulling location.
11+75	40-45		Heavy brush near fence - avoid this area
13+75	40-45	100	Low spot in line - install 3" blowoff
14+00	35-40		Trim tree branches. Begin transition back to fence.
14+50	10-20		Complete transition back to fence (no more trees)
15+00	15-20	70	(Grade rising. Approaching elevation of GJM Boulevard)
16+25	10-12	55	(Grade even with GJM Boulevard. Iceplant with no trees)
20+00	3-6	38	Trim tree branches near fence for access.
20+75	3-10	38	(Curb for San Pablo Avenue begins)
20+85	12	37	Begin U.G. transition of w.l. to cross San Pablo, if necessary.
21+40	12	0	Pavement of San Pablo begins.
22+00	12	0	pavement of San Pablo ends.
22+10	12	39	Begin transition to bring w.l. aboveground
22+25	12	40	w.l. aboveground; transition towards fence.
23+00	3-6	40	Trim solo juniper tree (high point of GJM) Install Air Vac valve
25+00	3-20	40	(iceplant area)

Station	Flange Location (feet of pipe)	Station E.P. (feet)	Comments
25+75	3-20	40	Potential HDPE assy. location. (Begin City of Seaside well parcel)
26+20	10-15	40	Begin U.G. transition of w.l. for well site access.
26+60	10-15	40	Return U.G. w.l. to A.G. (transition)
26+80	10-15	40	w.l. aboveground
27+15	5-15	40	Possible high point / location of Air Vac valve
27+20	3-6	40	(End of Seaside well parcel)
28+15	3-6	40	(Drainage ditch conn. to Seaside well blowoff)
29+75	3-6	39	(Opposite large transmission tower to east)
30+00	3-6	39	Iceplant area - no trees
35+00	15-20	38	Slight side hill slope, use 6x6 posts to keep w.l. up at 20' o.c. for 100'
35+50	15-20	38	Possible high point for Air Vac
39+50	15	38	(Opposite large transmission tower to east)
39+90	3-6	38	2 large bushes - transition towards fence and trim bushes as needed.
40+25	3-6	36	Begin AC curb for Broadway Avenue intersection.
41+25	3-6	36	(Cast iron C.B. in curb here on GJM Boulevard)
41+75	10-15	36	Dense bushes next to fence, bring w.l. 10 to 15 feet out into iceplant area.
42+00	20-25	35	Broadway intersection. Either directionally bore or trench. Pavement width is approximately 90', four lanes of traffic, two lanes each way. See Figure 3 for general area plan.
42+25	20	36	Two large Monterey Cypress trees
42+30	20-25	0	Begin pavement of Broadway (w.l. 3' U.G.)
43+20	20-25	0	End pavement of Broadway (w.l. 3' U.G.)
43+80	20-25	32	Transition w.l. to aboveground
44+20	20	32	Large concrete blocks (3) across infield area (traffic control ?)
44+50	20	32	Two large trees @ 12' from fence, stay out 20' until Station 44+75
45+00	20-15	32	Begin transition towards fence.
45+50	5-10	32	Grade depression near fence begins, stay 5 to 10 feet from fence. GJM Boulevard begins to rise above w.l. grade.
46+35	5-10	35	(Opposite 35 MPH sign and 8" pine trees)
47+00	10	37	(GJM Boulevard begins to curve to east)
47+50	10	39	Good spot for pulling or fusion equipment/HDPE assembly.
47+75	10	46	(Opposite large transmission tower to east.)
50+00	10-20	77	(GJM turnout on shoulder, 35 MPH sign.) Install Air Vac valve.
51+85	20	100+	Begin poison oak area.
52+50	20	100+	End poison oak area.

Station	Proposed Depth (ft)	Existing Depth (ft)	Comments
54+00	10-15	100+	Hill starts to rise steeply.
57+90	10-15	100+	(Opposite large transmission tower to east.)
58+75	15-20	100+	Peak of hill, locate Air Vac valve @ high point.
60+20	10-15	100+	South edge of City of Seaside Tank parcel. Side hill slope will require 6x6 posts installed @ 20' O.C. for 100'.
65+20	10-15	100+	(Opposite large transmission tower to east.)
65+50	10-15	90	Light iceplant area.
66+35	10-15	90	Scrub Oak near Fence, trim if needed.
67+55	10-15	90	Begin U.G. transition of w.l.
67+75	10-15	0	Begin pavement of Hilby Avenue.
68+00	10-15	0	Install 16" flange adaptor, 90° elbow, and conc. thrust block. Join to 16" w.l. section routed to Hilby tanks. End of HDPE line.

Notes:

AG aboveground
CLF chain link fence
pvmt pavement
GJM General Jim Moore Boulevard
c.i. cast iron
HDPE High Density Polyethylene Pipe
ug underground
w.l. water line

U:\Joel\wp\sscinj\2005\20-2354 techmemo.091404_joedits21sep04.doc

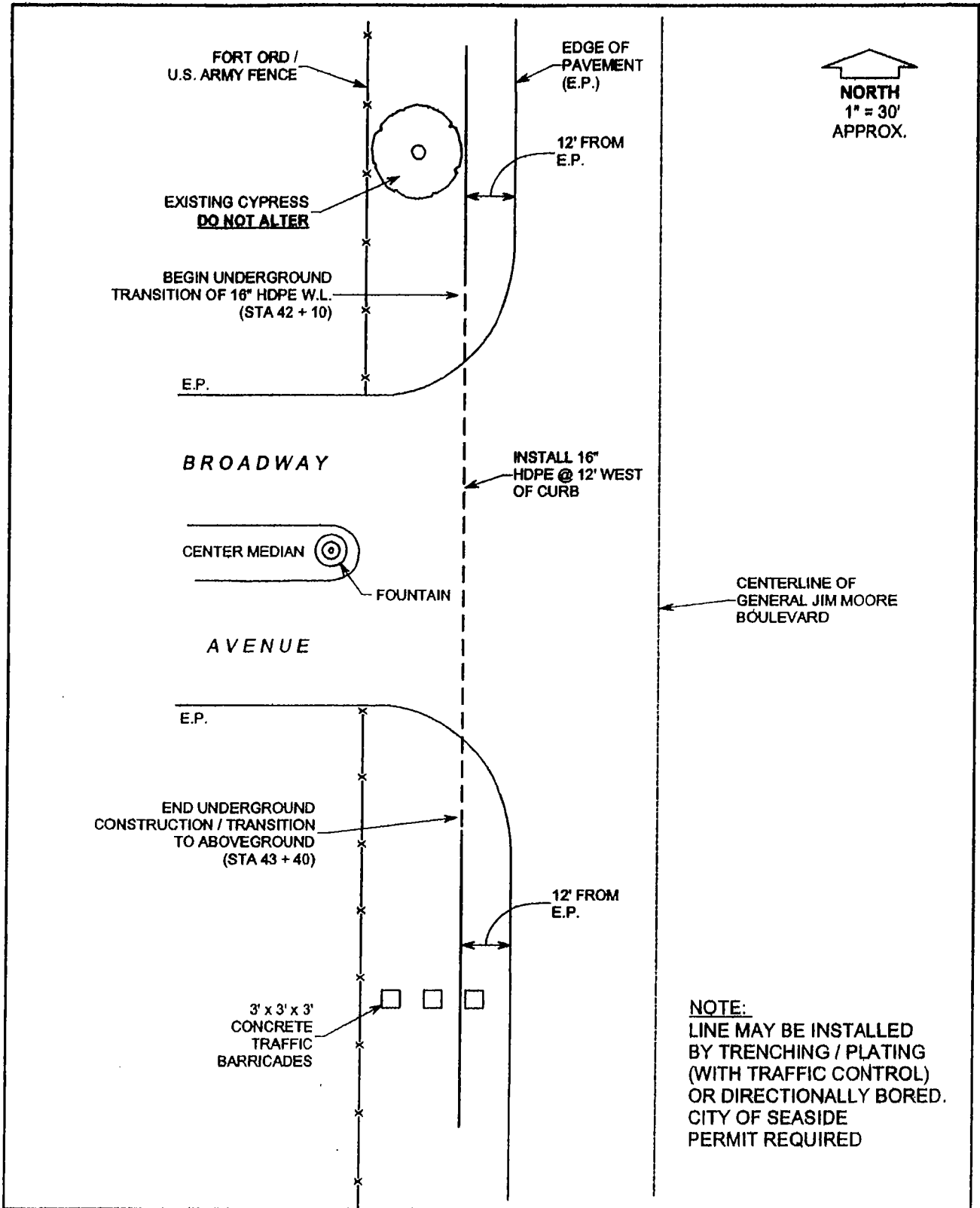

HDPE CROSSING OF BROADWAY AVENUE
 FIGURE 3

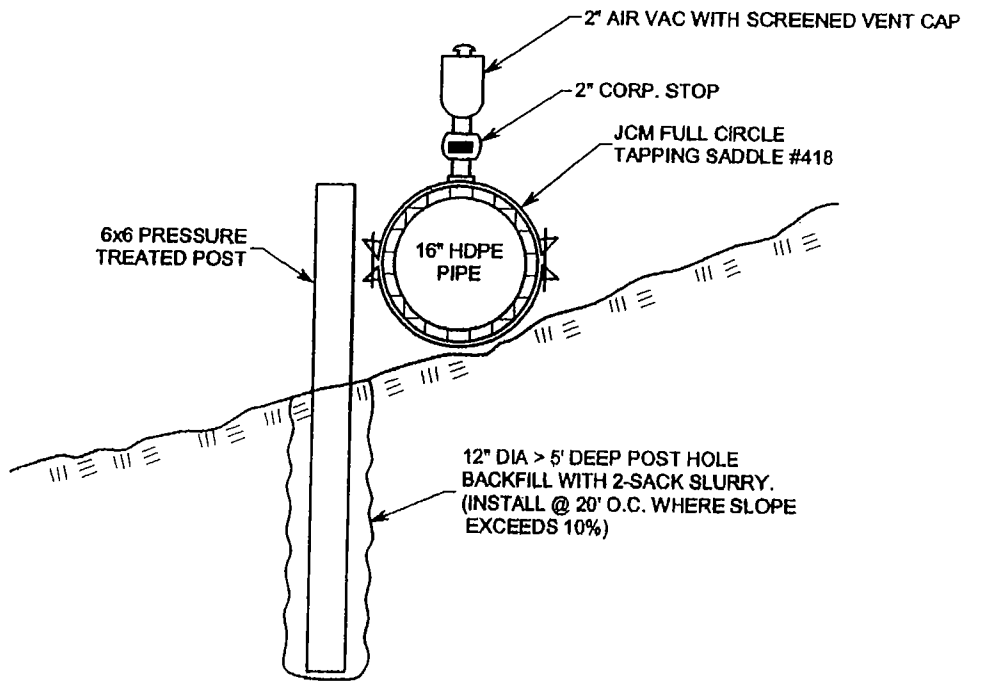
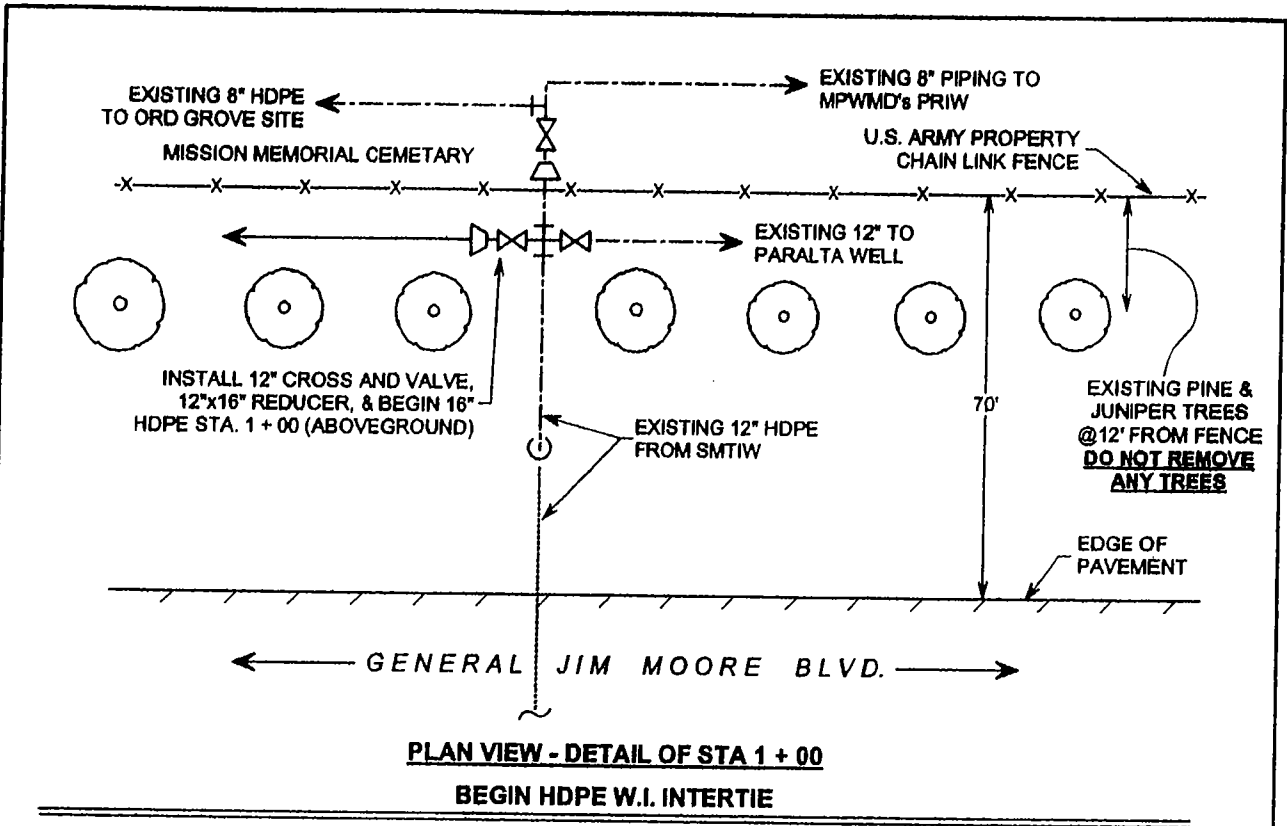

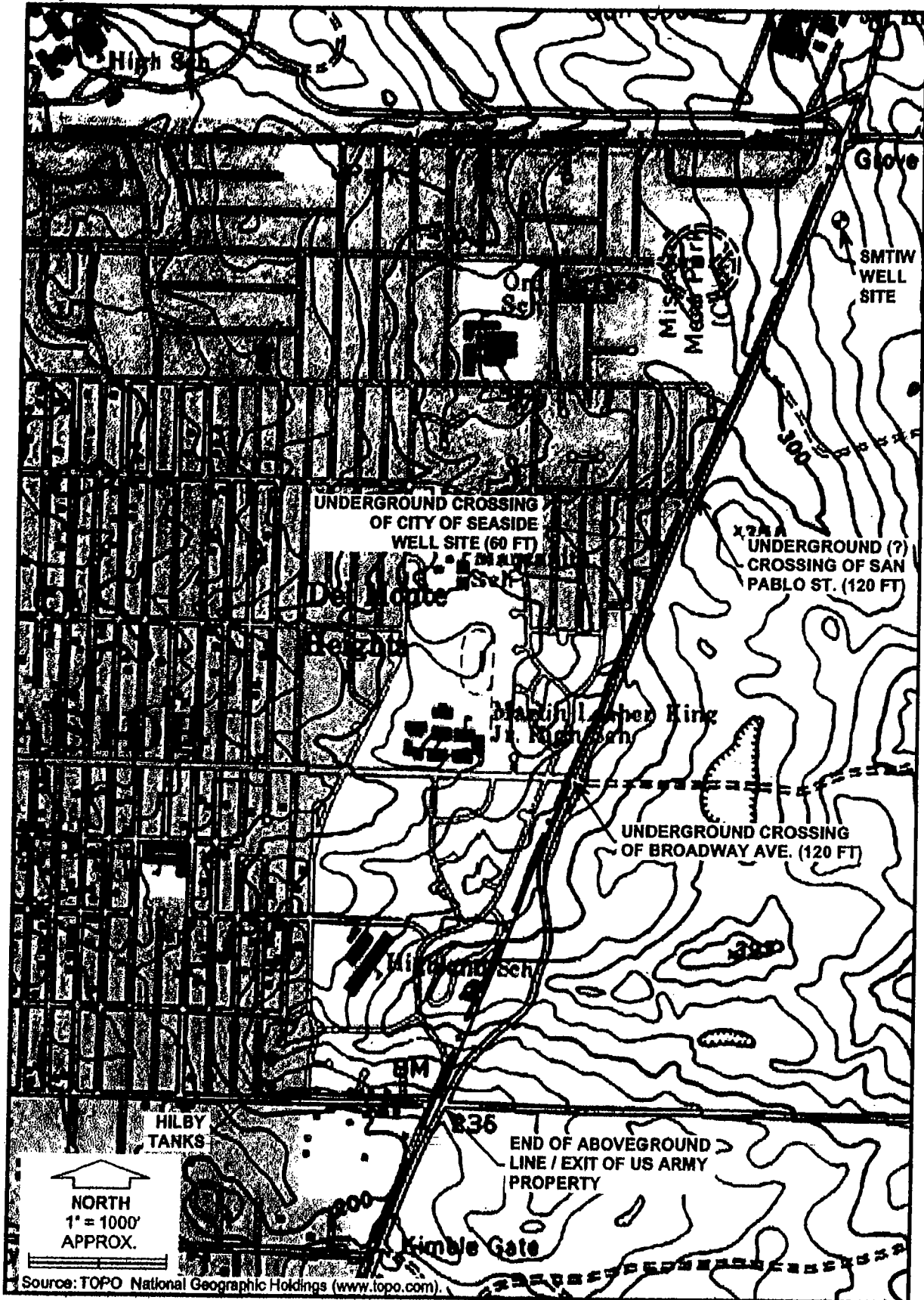

FILENAME: X

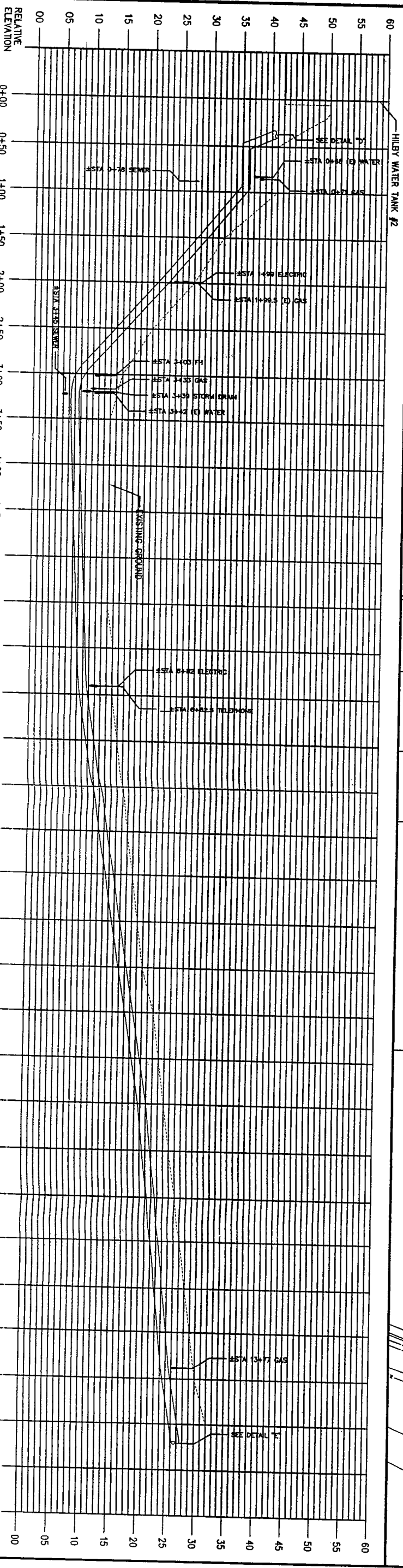

Yosemite Street to Hilby
(0+00 - 3+50)

PROFILE VIEW
1" = 50'

Hilby Avenue to General Jim Moore Road
(3+50 - 14+50)

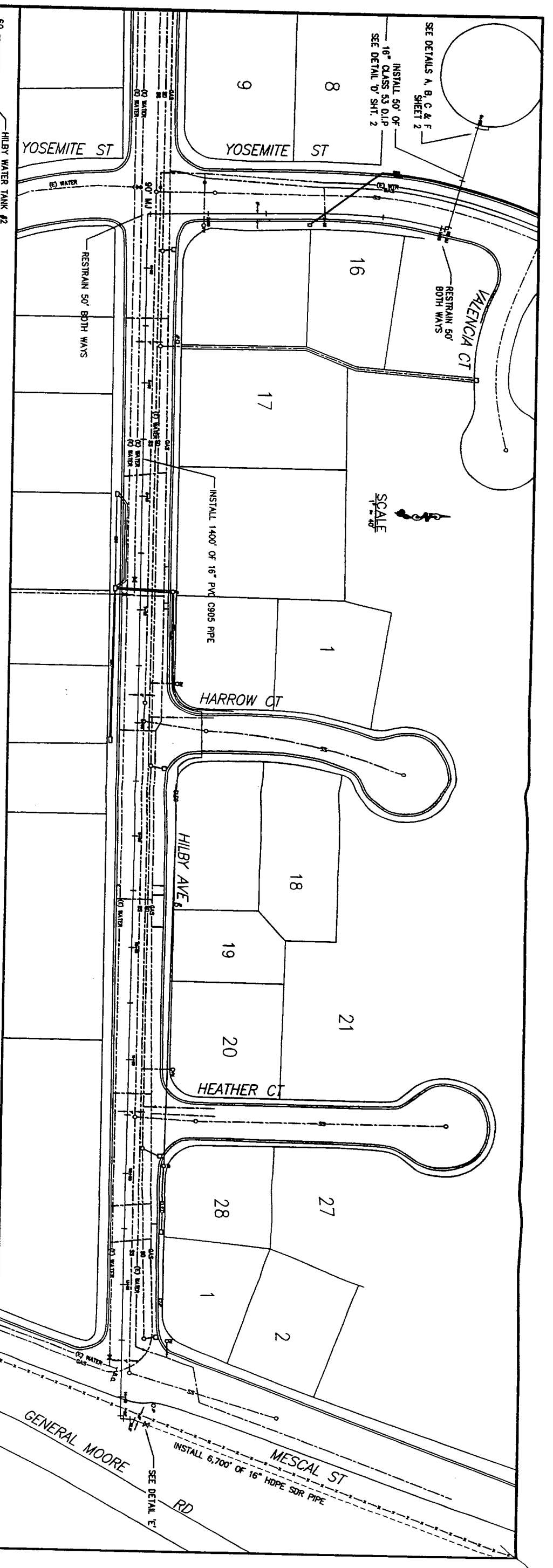

50 Roggeville Dr., Sta. 100, Monterey, Ca. 93912

REV	DESCRIPTION	BY	DATE	APPR

DATE	DESCRIPTION	BY	DATE
OCTOBER 2004	JPC		
	GLH		
	D.N.		
	FRED FEIZOLLAHI	X	

SANTA MARGARITA PIPELINE PROJECT
SEASIDE, CALIFORNIA
SANTA MARGARITA WELL TO HILBY TANK



PROJECT NUMBER: 0540
SHEET NO: X
OF 2

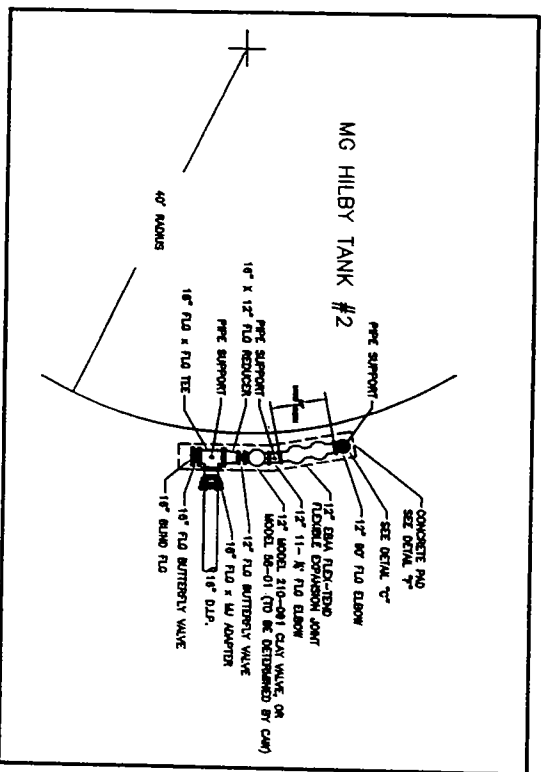

DETAIL A
NO SCALE

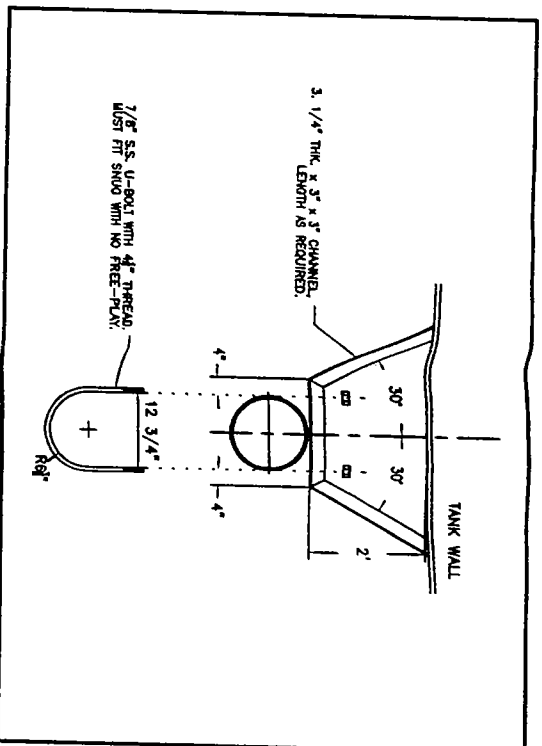

DETAIL B
PIPE BRACKET
NO SCALE

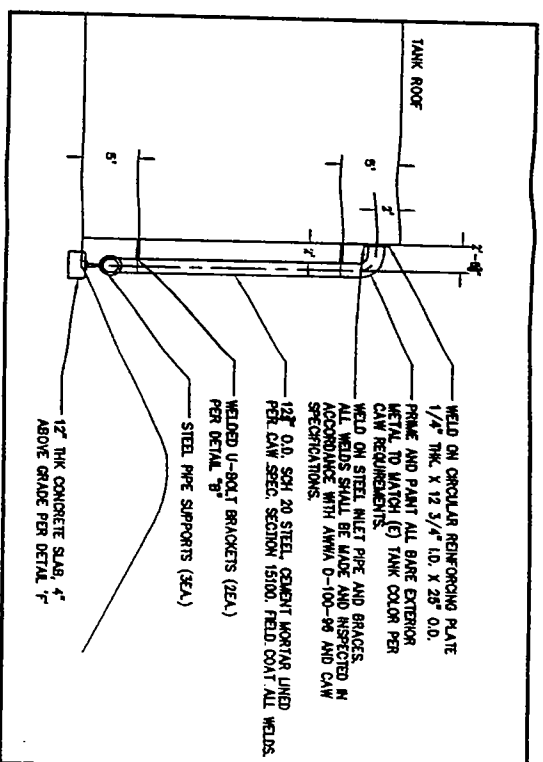

DETAIL C
WELDED STEEL INLET PIPE
NO SCALE

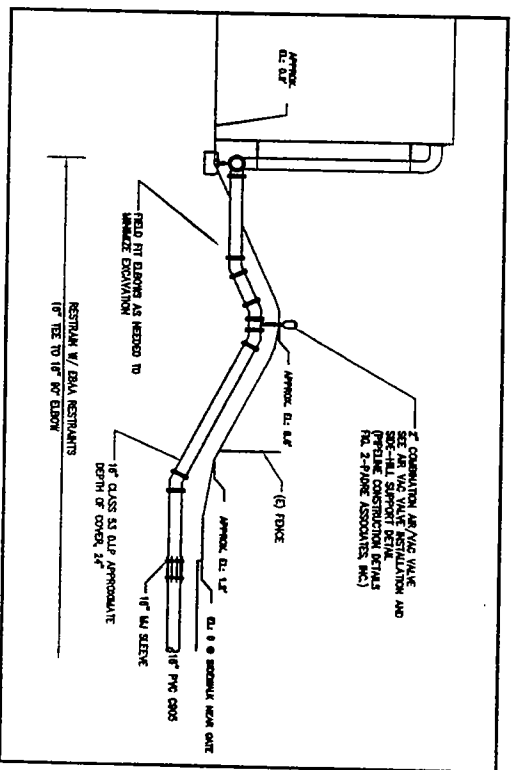

DETAIL D
1\"/>

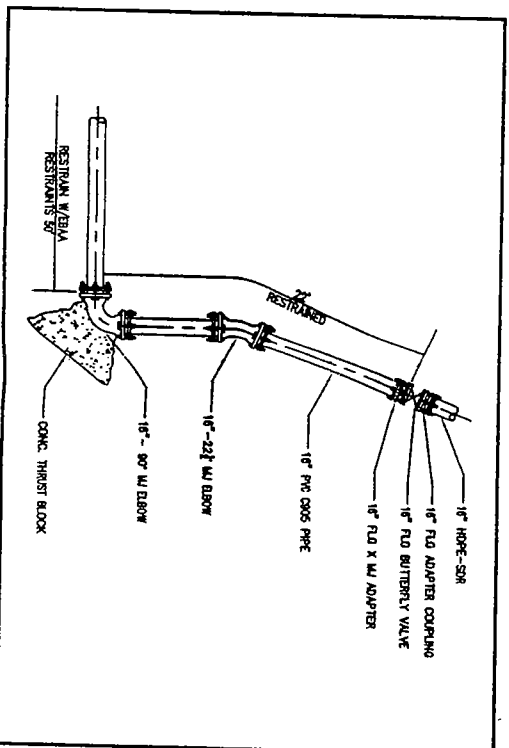

DETAIL E
NO SCALE

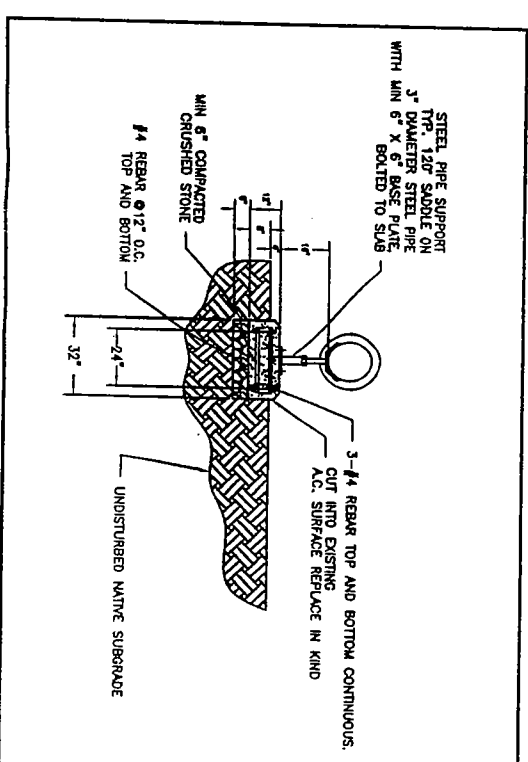

DETAIL F
CONCRETE SLAB AND PIPE SUPPORT
NO SCALE

FLRWAVE X



Monterey Division
80 Roggeville Dr., Sta. 100, Monterey, Ca. 93942

REV	DESCRIPTION	BY	DATE	APP

DATE	PROJECT NAME
OCTOBER 2004 <td>SANTA MARGARITA PIPELINE PROJECT-DETAILS</td>	SANTA MARGARITA PIPELINE PROJECT-DETAILS
DESIGNED BY	DATE
GLH.	
D.N.	
APPROVED BY	DATE
FRED FEIZOLLAHI	

SCALE	AS SHOWN

