

ADDENDUM No. 4

TO THE

AQUIFER STORAGE AND RECOVERY PROJECT ENVIRONMENTAL IMPACT REPORT/ENVIRONMENTAL ASSESSMENT

FOR THE

BACKFLUSH BASIN EXPANSION

July 11, 2018

Prepared for
Monterey Peninsula Water Management District

Prepared by
Denise Duffy and Associates



EXHIBIT 16-A

Addendum No. 4 to the ASR EIR/EA
Backflush Basin Expansion

This page is intentionally blank.

EXHIBIT 16-A

Addendum No. 4 to the ASR EIR/EA
Backflush Basin Expansion

TABLE OF CONTENTS

I. Introduction 1
II. Project Location 2
III. Project Description..... 2
IV. Comparison to the Conditions Listed in CEQA Guidelines Section15162 3
V. Changes to the Project..... 4

LIST OF FIGURES

1. Location Map..... 6
2. Site Plan 7
3. Surrounding Land Uses..... 8

LIST OF ATTACHMENTS

1. Initial Study Checklist for the Backflush Basin Modification to Support Addendum No. 4 to the ASR EIR/EA
2. Air Quality and GHG Calculations Spreadsheets dated July 5, 2018
3. Geotechnical Investigation for New Electrical & Chemical Feed Building prepared by Pacific Crest Engineering as Amended by Update Letter dated February 23, 2018
4. Approved MMRP for the Aquifer Storage and Recovery Project
5. Bid Drawings for Santa Margarita ASR Facility Site Expansion, prepared by MAC Design Associates and Pueblo Water Resources, dated May 25, 2018

EXHIBIT 16-A

Addendum No. 4 to the ASR EIR/EA
Backflush Basin Expansion

This page is intentionally blank.

EXHIBIT 16-A

Addendum No. 4 to the ASR EIR/EA
Backflush Basin Expansion

I. INTRODUCTION

Pursuant to the California Environmental Quality Act, California Public Resources Code Sections 21000 et seq. (CEQA) and the California Environmental Quality Act Guidelines, Title 14, Chapter 3 of the California Code of Regulations (CEQA Guidelines), and in cooperation with other affected agencies and entities, the Monterey Peninsula Water Management District (MPWMD) has prepared this Addendum to the Final Environmental Impact Report/Environmental Assessment for the Monterey Peninsula Water Management District Phase 1 Aquifer Storage and Recovery (ASR) Project (EIR/EA), certified by MPWMD's Board of Directors on August 21, 2006, as modified by:

- Addendum No. 1 to the ASR EIR/EA, which addressed full implementation of ASR Phase 2 and was adopted by MPWMD's Board of Directors on April 16, 2012;
- Addendum No. 2 to the ASR EIR/EA, which addressed the addition of the Hilby Pump Station and was adopted by MPWMD's Board of Directors on June 20, 2016; and,
- Addendum No. 3 to the ASR EIR/EA, which addressed the Monterey Pipeline and was adopted by MPWMD's Board of Directors on February 22, 2017.

MPWMD has prepared this Addendum to the ASR EIR/EA to address the effects of constructing and operating the proposed Backflush Basin Expansion, which would constitute a change to the ASR Project. This Addendum evaluates the proposed expansion of the existing backflush basin at the ASR Santa Margarita site, to accommodate the increased backflush water from nearby existing and planned ASR wells.

The ASR Project entails diversion of "excess" Carmel River winter flows, as allowed under water rights permits issued by the State Water Resources Control Board, which is then treated and transmitted via the CalAm distribution system to specially-constructed injection/recovery wells, known as ASR wells, in the Seaside Groundwater Basin and injected under an authorization from the Environmental Protection Agency (EPA). The excess water is diverted by CalAm wells only during periods when flows in the Carmel River exceed fisheries bypass flow requirements. After treatment to potable drinking water standards, water is then conveyed through CalAm's distribution system to ASR facilities (injection wells) to recharge the over-pumped Seaside Groundwater Basin. Available storage capacity in the Seaside Groundwater Basin serves as an underground reservoir for the diverted water. Water is then pumped back out from the Seaside Groundwater Basin in dry periods to help reduce pumping-related impacts on the Carmel River. This "conjunctive use" more efficiently utilizes local water resources to improve the reliability of the community's water supply while reducing the environmental impacts to the Carmel River and Seaside Groundwater Basins.

This Addendum evaluates whether construction and operation of the proposed expansion of the backflush basin would result in a new significant impact, or an impact that is substantially more severe than the impacts disclosed in the ASR EIR/EA as amended. This Addendum is supported by **Attachment 1, Initial Study Checklist for the Backflush Basin Expansion**, which concludes the following in accordance with CEQA Guidelines Section 15464:

- No new or previously unidentified adverse significant impacts would result from the construction and operation of the Backflush Basin Modification.

EXHIBIT 16-A

Addendum No. 4 to the ASR EIR/EA
Backflush Basin Expansion

- The proposed Backflush Basin Expansion would not result in a substantial increase in the severity of the impacts identified in the ASR EIR/EA.

MPWMD's Board of Directors will consider this Addendum, along with the certified ASR EIR/EA and its Addenda, prior to making a decision on any approvals pertaining to the proposed Backflush Basin Expansion.

II. PROJECT LOCATION

The existing ASR backflush basin is located in the City of Seaside, southeast of the intersection of General Jim Moore Boulevard and Eucalyptus Road, in an area known as the Santa Margarita Site. **Figure 1. Location Map** shows the location of the facility within the City of Seaside.

III. PROJECT DESCRIPTION

The project involves the expansion of the existing backflush basin to accommodate the increased backflush water from the existing ASR facility at Seaside Middle School and a planned ASR facility at Fitch Park. The Addendum to the MPWMD Aquifer Storage and Recovery Project Phase 1 EIR/EA dated April 2012, identified a backflush pit at Seaside Middle School; this backflush pit was never built at the Middle School site. Backflush water is conveyed from ASR Wells 3 and 4 located the Seaside Middle School site to the existing Santa Margarita backflush pit. The Proposed Project would allow the backflush pit that was proposed at the Seaside Middle School to be built at the Santa Margarita site via an expansion of the existing backflush pit. Additionally, CalAm is planning on construction ASR Wells 5 and 6 at the future Fitch Park site¹. Due to land constraint, a backflush basin cannot fit at that site and backflush water will be conveyed to the Santa Margarita site. The Santa Margarita backflush basin is being expanded in lieu of constructing a separate 240,000-gallon backflush basin at Seaside Middle School and Fitch Park sites². To accommodate the increased backflush water on a schedule that is operationally feasible, the backflush basin would be expanded to increase backflush capacity to approximately 750,000-gallon capacity.

Other than providing additional capacity, the expansion of the backflush basin would not change operations of the ASR Project. The Santa Margarita site is currently 1.1 acres, MPWMD proposes to expand this site to approximately 1.9 acres.

New and revised facilities are identified below based upon details from MPWMD and the basis of design information:

- Grading and contouring to facilitate construction and improve access;
- Second driveway on General Jim Moore Boulevard to facilitate Operations and Maintenance activities during construction and major maintenance activities;
- Backflush basin expansion, as noted above;

¹ ASR Wells 5 and 6 facilities are evaluated in the Monterey Peninsula Water Supply Project EIR.

² Draft ASR EIR/EA dated March 2006 identifies a 240,000-gallon backflush percolation pit, located in the southwest corner of the Santa Margarita site. The terms backflush pit, backflush percolation pit and backflush basin are equivalent.

EXHIBIT 16-A

Addendum No. 4 to the ASR EIR/EA
Backflush Basin Expansion

- New frontage fence; and
- Two new sound walls, not currently proposed, included in anticipation of future works.

Together, these components comprise the Backflush Basin Expansion, or Proposed Project.

Typical earth moving equipment will be used during construction of works including clearing and trenching. All deleterious material and soil must remain onsite due to unexploded ordnance concerns.

Construction is anticipated to begin in August 2018 and will last a maximum of four months. Construction will occur Monday through Friday from 7am to 7pm.

It is estimated that four (4) workers will be required onsite during construction. They would generate eight (8) one-way trips per day. Materials and equipment will also be delivered to the site; however, these deliveries would be minimal (estimated to be about 5 deliveries for the duration of construction). Construction workers will access the site from the existing driveway and will park onsite. Traffic control will be required during the installation of the driveway. Traffic controls will include, at a minimum, measures to ensure safety of pedestrians and bicyclists on General Jim Moore Boulevard.

IV. COMPARISON TO THE CONDITIONS LISTED IN CEQA GUIDELINES SECTION 15162

This Addendum has been prepared pursuant to CEQA Guidelines Section 15164, which states: "A lead agency or responsible agency shall prepare an addendum to a previously certified EIR if some changes or additions are necessary but none of the conditions described in Section 15162 calling for preparation of a subsequent EIR have occurred." CEQA Guidelines Section 15162 establishes the following criteria for the preparation of a Supplemental EIR.

- 1) Substantial changes are proposed in the project which will require major revisions of the previous EIR or negative declaration due to the involvement of new significant environmental effects or a substantial increase in the severity of previously identified significant effects;
- 2) Substantial changes occur with respect to the circumstances under which the project is undertaken which will require major revisions of the previous EIR or negative declaration due to the involvement of new significant environmental effects or a substantial increase in the severity of previously identified significant effects; or
- 3) New information of substantial importance, which was not known and could not have been known with the exercise of reasonable diligence at the time the previous EIR was certified as complete or the negative declaration was adopted, shows any of the following:
 - a) The project will have one or more significant effects not discussed in the previous EIR or negative declaration;
 - b) Significant effects previously examined will be substantially more severe than shown in the previous EIR;
 - c) Mitigation measures or alternatives previously found not to be feasible would in fact be feasible and would substantially reduce one or more significant effects of the project, but the project proponents decline to adopt the mitigation measure or alternative; or

EXHIBIT 16-A

Addendum No. 4 to the ASR EIR/EA
Backflush Basin Expansion

- d) Mitigation measures or alternatives which are considerably different from those analyzed in the previous EIR would substantially reduce one or more significant effects on the environment, but the project proponents decline to adopt the mitigation measure or alternative.

The following discussion summarizes the reasons why a subsequent or supplemental EIR, pursuant to CEQA Guidelines Section 15162, is not required in connection with approvals for the proposed Backflush Basin Expansion and why an addendum is appropriate.

V. CHANGES TO THE PROJECT

1. Project Background

The ASR EIR/EA and its Addenda did not contemplate the Expansion of the Backflush Basin. The full ASR EIR/EA can be accessed on the MPWMD website, more specifically, online at the following address: <http://www.mpwmd.net/wp-content/uploads/2015/08/MPWMD-Draft-EIR-EA-3-06.pdf>

Addendum No. 1 to that document can be found online at the following address: http://www.mpwmd.net/asd/board/boardpacket/2012/20120416/16/item16_exh16b.pdf, Addendum No. 2 can be found here: <http://www.mpwmd.net/asd/board/boardpacket/2016/20160620/16/Item-16-Exh-A.pdf>, and Addendum No. 3 can be found here: [http://www.mcwd.org/docs/agenda_minutes/2016-04-18_board/Item%209-C%20-%20FINAL%20PUBLIC%20REVIEW%20RUWAP%20Shared%20Pipeline%20Addendum_%20No3_March%202020%20\(2\).pdf](http://www.mcwd.org/docs/agenda_minutes/2016-04-18_board/Item%209-C%20-%20FINAL%20PUBLIC%20REVIEW%20RUWAP%20Shared%20Pipeline%20Addendum_%20No3_March%202020%20(2).pdf).

2. Environmental Effects

As detailed in **Attachment 1, Initial Study Checklist for the Backflush Basin Expansion**, the proposed Backflush Basin Expansion would not result in any new significant environmental effects that cannot be mitigated with existing, previously identified mitigation measures in the ASR EIR/EA and its Addenda. In addition, the proposed Backflush Basin Expansion would not substantially increase the severity of environmental effects identified in the ASR EIR/EA and its Addenda.

3. New Information

No new information of substantial importance has been identified or presented to MPWMD such that the ASR Project would result in: 1) significant environmental effects not identified in the ASR EIR/EA and its Addenda, or 2) more severe environmental effects than described in the ASR EIR/EA and its Addenda, or 3) require mitigation measures which were previously determined not to be feasible, or mitigation measures that are considerably different from those recommended in the ASR EIR/EA and its Addenda.

4. Conclusion

Section 15164 of the CEQA Guidelines states that a lead agency or responsible agency shall prepare an addendum to a previously certified EIR if some changes or additions are necessary but none of the conditions described in Section 15162 calling for preparation of a subsequent EIR have occurred. Based on the information in this Addendum, MPWMD has determined that:

EXHIBIT 16-A

Addendum No. 4 to the ASR EIR/EA
Backflush Basin Expansion

- No new significant environmental effects or a substantial increase in the severity of previously identified significant effects would occur as a result of the construction and operation of the Backflush Basin Expansion;
- No substantial changes have occurred or would occur with respect to the circumstances under which the ASR Project was originally undertaken, which would require major revisions to the previously certified ASR EIR/EA due to the involvement of new significant environmental effects or a substantial increase in the severity of previously identified significant effects; and
- No new information of substantial importance has been received or discovered, which was not known and could not have been known with the exercise of reasonable diligence at the time the previous ASR EIR/EA and its Addenda were certified as complete.

EXHIBIT 16-A

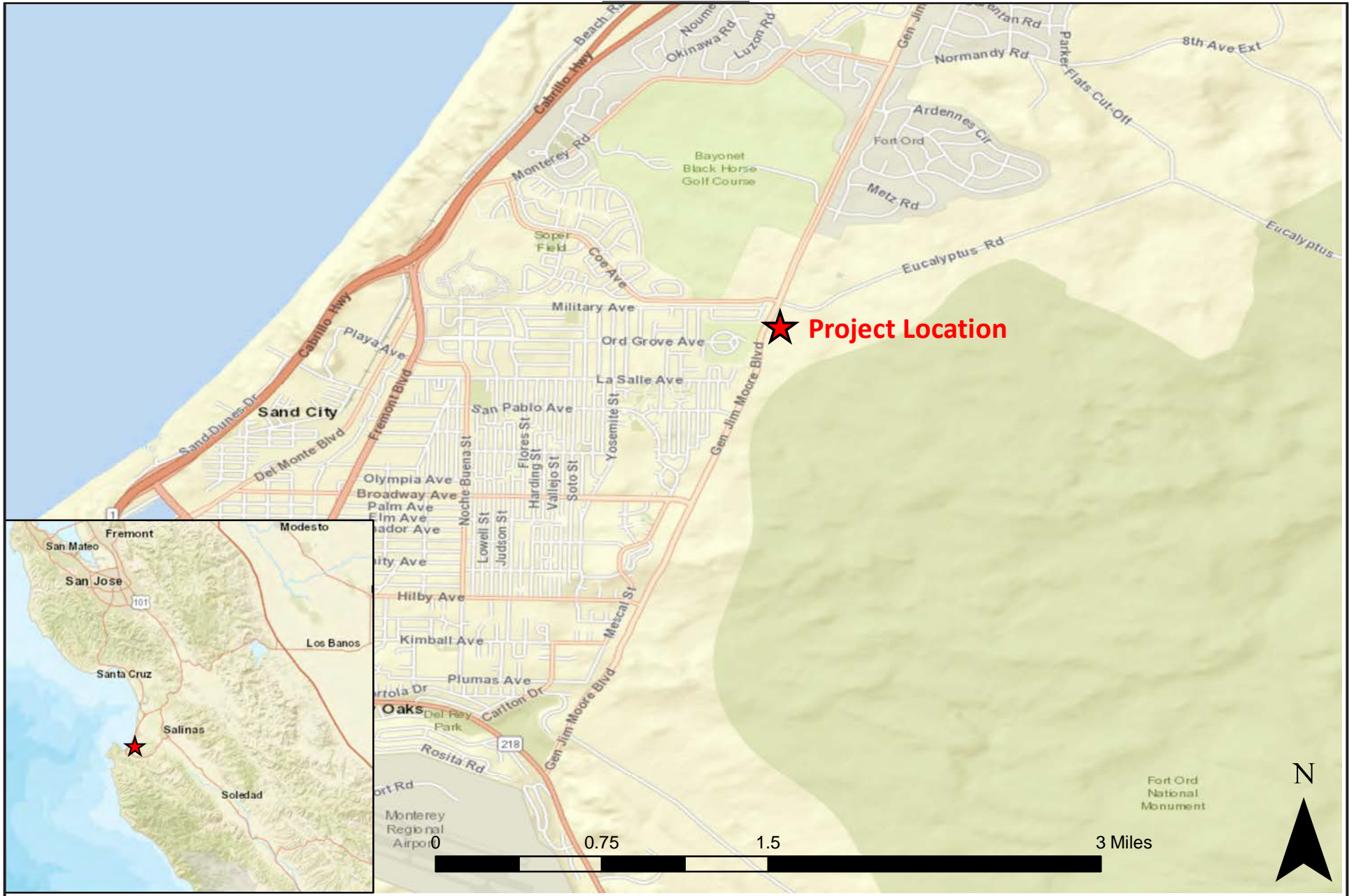

Location Map

July 2018

Addendum No. 4 to the Aquifer Storage and Recovery EIR/EA
Backflush Basin Modifications

Figure
1

EXHIBIT 16-A



Site Plan

July 2018

Addendum No. 4 to the Aquifer Storage and Recovery EIR/EA
Backflush Basin Modifications

Figure
2



Surrounding Land Uses

July 2018

Addendum No. 4 to the Aquifer Storage and Recovery EIR/EA
Backflush Basin Modifications

Figure
3

EXHIBIT 16-A

Backflush Basin Expansion

ATTACHMENT 1

**INITIAL STUDY CHECKLIST FOR THE BACKFLUSH BASIN EXPANSION TO
SUPPORT ADDENDUM NO. 4 TO THE ASR EIR/EA**

EXHIBIT 16-A

Backflush Basin Expansion

This page is intentionally blank.

EXHIBIT 16-A

Initial Study Checklist
Backflush Basin Expansion

I. PROJECT DATA

Project Title: Backflush Basin Expansion

Lead Agency Name and Address: Monterey Peninsula Water Management District (MPWMD), 5 Harris Court, Building G, Monterey, CA 93940, Mailing Address is: PO Box 85, Monterey, CA 93942-0085

Contact Person and Phone Number: Maureen Hamilton, (831) 658-5622

Project Proponents: Monterey Peninsula Water Management District (MPWMD)

Project Location: The proposed Backflush Basin Expansion would be located at the existing Santa Margarita ASR Site, which is southeast of the intersection of General Jim Moore Boulevard and Eucalyptus Road in the City of Seaside.

City of Seaside General Plan Designation: Low Density Single Family Residential¹

Zoning: Single Family Residential (RS-8)

Project Description: MPWMD proposes to expand the existing Backflush Basin to a capacity of 750,000 gallons. In addition, the following site modification will be made in connection with the Backflush Basin expansion:

- Grading and contouring to facilitate construction and improve access;
- Second driveway on General Jim Moore Boulevard to facilitate Operations and Maintenance activities during construction and major maintenance activities;
- Backflush basin expansion, as noted above;
- New frontage fence; and
- Two new sound walls; not currently proposed, included in anticipation of future works.

Together, these components comprise the Backflush Basin Expansion, or Proposed Project.

Surrounding Land Uses:

- North: Eucalyptus Road followed by open space
- South: Open space
- East: Open space
- West: General Jim Moore Boulevard followed by residential and a cemetery

¹ This parcel is currently designated as Low Density Single Family Residential in the 2003 Seaside General Plan, however, it is designated as "Future Specific Plan" in *Figure 6. General Plan Designations* in the Draft Seaside 2040 General Plan. The Final Seaside 2040 General Plan is expected to be released in late 2018.

EXHIBIT 16-A

Initial Study Checklist
Backflush Basin Expansion

II. ENVIRONMENTAL FACTORS POTENTIALLY AFFECTED

All of the following environmental factors identified below are discussed within **Section III. Evaluation of Environmental Impacts**. Those that are checked were found to be areas that the full implementation of the proposed Backflush Basin Modification may significantly impact without mitigation. Sources used for analysis of environmental effects are listed in **Section IV. References**.

- | | | |
|---|---|---|
| <input type="checkbox"/> Aesthetics | <input type="checkbox"/> Agricultural Resources | <input type="checkbox"/> Air Quality |
| <input type="checkbox"/> Biological Resources | <input checked="" type="checkbox"/> Cultural Resources | <input type="checkbox"/> Geology and Soils |
| <input type="checkbox"/> Greenhouse Gas Emissions | <input checked="" type="checkbox"/> Hazards and Hazardous Materials | <input type="checkbox"/> Hydrology and Water Quality |
| <input type="checkbox"/> Land Use and Planning | <input type="checkbox"/> Mineral Resources | <input type="checkbox"/> Noise |
| <input type="checkbox"/> Population and Housing | <input type="checkbox"/> Public Services | <input type="checkbox"/> Recreation |
| <input type="checkbox"/> Transportation and Traffic | <input type="checkbox"/> Utilities and Service Systems | <input type="checkbox"/> Mandatory Findings of Significance |

III. EVALUATION OF ENVIRONMENTAL IMPACTS

1. Aesthetics

EXISTING SETTING

The existing site is located in a disturbed area, south east of the intersection of General Jim Moore Boulevard and Eucalyptus Road in the City of Seaside. The Proposed Project site is not visible from Highway 1 or located near a designated scenic vista. The Proposed Project site is located on the Former Fort Ord. The existing Santa Margarita site is a water infrastructure facility. The surrounding area is primarily open space. The visual quality of the site is considered medium, as it is surrounding primarily by open space which is characteristic of the region’s natural visual amenities. The overall visual sensitivity of the site is considered low, as there are existing water infrastructure facilities within the Proposed Project site.

CHECKLIST

	Potentially Significant Impact	Less than Significant with Mitigation Incorporated	Less than Significant Impact	No Impact
Would the project:				
a) Have a substantial adverse effect on a scenic vista?	<input type="checkbox"/>	<input type="checkbox"/>	<input checked="" type="checkbox"/>	<input type="checkbox"/>
b) Substantially damage scenic resources, including, but not limited to, trees, rock outcroppings, and historic buildings within a state scenic highway?	<input type="checkbox"/>	<input type="checkbox"/>	<input checked="" type="checkbox"/>	<input type="checkbox"/>
c) Substantially degrade the existing visual character or quality of the site and its surroundings?	<input type="checkbox"/>	<input type="checkbox"/>	<input checked="" type="checkbox"/>	<input type="checkbox"/>
d) Create a new source of substantial light or glare which would adversely affect day or nighttime views in the area?	<input type="checkbox"/>	<input type="checkbox"/>	<input type="checkbox"/>	<input checked="" type="checkbox"/>

EXHIBIT 16-A

Initial Study Checklist
Backflush Basin Expansion

SUMMARY OF IMPACTS IN PREVIOUS DOCUMENTS

- The ASR EIR/EA identified less than significant impacts related to scenic views, degradation of visual character, creation of light and glare during construction activities, and alteration of existing visual character. The ASR EIR/EA identified a significant impact resulting from creation of new light and glare associated with well operation that would be reduced to less than significant with implementation of *Mitigation Measure VIS-3: Incorporate Light-Reduction Measures into the Plan and Design of Exterior Lighting at Well Site*.
- Addendum No. 1 to the ASR EIR/EA also identified a potentially significant impact would result from implementation of ASR Phase 2 related to the creation of new light and glare at the well site, however, this impact would be reduced to less than significant with the implementation of *Mitigation Measure VIS-3: Incorporate Light-Reduction Measures into the Plan and Design of Exterior Lighting at Well Site*.
- Addendum No. 2 to the ARS EIR/EA did not identify any potentially significant aesthetic impacts related to the construction and operation of the Hilby Pump Station.
- Addendum No. 3 to the ARS EIR/EA did not identify any additional potentially significant aesthetic impacts related to the Monterey Pipeline Re-Alignment.

DISCUSSION

Construction of the Backflush Basin Expansion would last approximately four months. The stockpiled soil⁴ generated by excavation of the backflush basin expansion and contouring of the site, the fence, and the sound walls, would be the above ground components of the Proposed Project that would be visible from a public right of way after construction.

a, b) Less Than Significant Impact. The proposed Backflush Basin Expansion are not located within a scenic highway corridor. The Proposed Project site is located in an area that offers a scenic vista of the Former Fort Ord to the east, which contains rolling hills vegetated with coastal chaparral.

The soil stockpile would be approximately five (5) feet in height and would be located behind the existing electrical building. The soil stockpile is likely to become revegetated with local plant species over time. The proposed fence would be less than ten (10) feet in height and has been designed in consultation with City of Seaside staff for attractiveness and aesthetic compatibility with future land use. The fence would be minimally visible to motorists and pedestrians traveling on General Jim Moore Boulevard due to the topography of the site. The sound walls would be up to sixteen feet in height. They would be set back a distance from General Jim Moore Boulevard. The final height and material of the proposed sound walls would be approved by the City of Seaside prior to their construction. The proposed concrete driveway and clearing of low-lying vegetation would be located at ground level and would therefore be minimally visible from motorist and pedestrians traveling on General Jim Moore Boulevard. For these reasons the Proposed Project will have a less than significant impact to scenic vista and scenic resources.

c) Less than Significant Impact. The Backflush Basin Expansion would result in minimal changes to the visual character of the proposed site, as the existing site is currently disturbed and contains water infrastructure facilities. The proposed modifications would result in a maximum disturbed area of 1.9 acres during construction. After construction is complete, minimal change to the visual character of the

⁴ Due to the potential for hazardous materials within excavated soil, the Fort Ord Reuse Authority (FORA) requires that all soil generated onsite must remain on the parcel.

EXHIBIT 16-A

Initial Study Checklist
Backflush Basin Expansion

site will be evident, as the expansion of the backflush basin does not involve any above-ground structures. This impact is considered to be less than significant.

d) No Impact. The Proposed Project would not introduce any new sources of light and glare, as no new lighting is proposed as part of the project. The Backflush Basin Expansion would have no impact on day or nighttime views due to light or glare.

CONCLUSION

The proposed Backflush Basin Expansion would not result in any new significant impacts or cause an increase in severity of any significant impacts identified in the ASR EIR/EA related to aesthetic resources.

2. Agricultural Resources

EXISTING SETTING

The proposed Backflush Basin Expansion and its surrounding area do not contain agricultural or forest lands.

CHECKLIST

In determining whether impacts to agricultural resources are significant environmental effects, lead agencies may refer to the California Agricultural Land Evaluation and Site Assessment Model (1997) prepared by the California Dept. of Conservation as an optional model to use in assessing impacts on agriculture and farmland. In determining whether impacts to forest resources, including timberland, are significant environmental effects, lead agencies may refer to information compiled by the California Department of Forestry and Fire Protection regarding the state’s inventory of forest land, including the Forest and Range Assessment Project and the Forest Legacy Assessment project; and forest carbon measurement methodology provided in Forest Protocols adopted by the California Air Resources Board. Would the project:	Potentially Significant Impact	Less than Significant with Mitigation Incorporated	Less than Significant Impact	No Impact
a) Convert Prime Farmland, Unique Farmland, or Farmland of Statewide Importance (Farmland), as shown on the maps prepared pursuant to the Farmland Mapping and Monitoring Program of the California Resources Agency, to non-agricultural use?	<input type="checkbox"/>	<input type="checkbox"/>	<input type="checkbox"/>	<input checked="" type="checkbox"/>
b) Conflict with existing zoning for agricultural use, or a Williamson Act contract?	<input type="checkbox"/>	<input type="checkbox"/>	<input type="checkbox"/>	<input checked="" type="checkbox"/>
c) Conflict with existing zoning for, or cause rezoning of, forest land (as defined in Public Resources Code section 12220(g)), timberland (as defined by Public Resources Code section 4526), or timberland zoned Timberland Production (as defined by Government Code section 51104(g))?	<input type="checkbox"/>	<input type="checkbox"/>	<input type="checkbox"/>	<input checked="" type="checkbox"/>
d) Result in the loss of forest land or conversion of forest land to non-forest use?	<input type="checkbox"/>	<input type="checkbox"/>	<input type="checkbox"/>	<input checked="" type="checkbox"/>
e) Involve other changes in the existing environment which, due to their location or nature, could result in conversion of	<input type="checkbox"/>	<input type="checkbox"/>	<input type="checkbox"/>	<input checked="" type="checkbox"/>

EXHIBIT 16-A

Initial Study Checklist
Backflush Basin Expansion

<p>In determining whether impacts to agricultural resources are significant environmental effects, lead agencies may refer to the California Agricultural Land Evaluation and Site Assessment Model (1997) prepared by the California Dept. of Conservation as an optional model to use in assessing impacts on agriculture and farmland. In determining whether impacts to forest resources, including timberland, are significant environmental effects, lead agencies may refer to information compiled by the California Department of Forestry and Fire Protection regarding the state’s inventory of forest land, including the Forest and Range Assessment Project and the Forest Legacy Assessment project; and forest carbon measurement methodology provided in Forest Protocols adopted by the California Air Resources Board. Would the project:</p>	<p>Potentially Significant Impact</p>	<p>Less than Significant with Mitigation Incorporated</p>	<p>Less than Significant Impact</p>	<p>No Impact</p>
<p>Farmland, to non-agricultural use or conversion of forest land to non-forest use?</p>				

SUMMARY OF IMPACTS IN PREVIOUS DOCUMENTS

- No impacts to agricultural resources were identified in the ASR EIR/EA.
- No impacts to agricultural resources were identified in Addendum No. 1 to the ASR EIR/EA resulting from the implementation of ASR Phase 2.
- Addendum No. 2 to the ASR EIR/EA did not identify any potentially significant impacts to agricultural resources resulting from the construction and operation of the Hilby Pump Station.
- Addendum No. 3 to the ASR EIR/EA did not identify any potentially significant impacts to agricultural resources related to the Monterey Pipeline Re-Alignment.

DISCUSSION

a-e) No Impact. The proposed Backflush Basin Expansion site and its surrounding area do not contain agricultural or forest lands. The proposed Backflush Basin Expansion would not convert prime, unique, or farmland of statewide importance to non-agricultural use or involve any other changes that would result in the conversion of farmland, impact a Williamson Act contract, or disrupt any agricultural operations (Monterey County, 2010a). The proposed Backflush Basin Expansion would not convert forest land or timberland or involve any other changes that would result in the conversion or loss of forest land.

CONCLUSION

The proposed Backflush Basin Expansion would not result in any new significant impacts or cause an increase in severity of any significant impacts identified in the ASR EIR/EA related to agricultural resources.

3. Air Quality

EXISTING SETTING

The proposed Backflush Basin Expansion would be located in the North Central Coast Air Basin (Air Basin). The Air Basin covers an area of 5,159 square miles along the central coast of California and is generally bounded by the Monterey Bay to the west, the Santa Cruz Mountains to the northwest, the Diablo Range on the northeast (Denise Duffy and Associates, 2015).

EXHIBIT 16-A

Initial Study Checklist
Backflush Basin Expansion

The proposed Backflush Basin Expansion area typically has average maximum and minimum winter (i.e., January) temperatures of 60 degrees Fahrenheit (°F) and 43 °F, respectively, while average summer (i.e., July) maximum and minimum temperatures are 68 °F and 52 °F, respectively. The proposed Backflush Basin Expansion site is within close proximity to the coast with temperature variations that are relatively moderate. Precipitation in the proposed Backflush Basin Expansion site averages approximately 20 inches per year (Denise Duffy and Associates, 2015).

The Monterey Bay Air Resources District (MBARD) is the regional agency tasked with managing air quality in the region. Existing levels of air pollutants in the proposed Backflush Basin Expansion area can generally be inferred from ambient air quality measurements conducted by MBARD at its closest station, the Salinas #3 monitoring station, located in the City of Salinas, east of East Laurel Drive and south of Constitution Boulevard. Data monitored at this station shows that although the area currently does not meet state standards for ozone, the number of days per year in exceedance of ozone standards has been decreasing, and the region is on course to meet these standards in the future.

CHECKLIST

Where available, the significance criteria established by the applicable air quality management or air pollution control district may be relied upon to make the following determinations. Would the project:	Potentially Significant Impact	Less than Significant with Mitigation Incorporated	Less than Significant Impact	No Impact
a) Conflict with or obstruct implementation of the applicable air quality plan?	<input type="checkbox"/>	<input type="checkbox"/>	<input checked="" type="checkbox"/>	<input type="checkbox"/>
b) Violate any air quality standard or contribute substantially to an existing or projected air quality violation?	<input type="checkbox"/>	<input type="checkbox"/>	<input checked="" type="checkbox"/>	<input type="checkbox"/>
c) Result in a cumulatively considerable net increase of any criteria pollutant for which the project region is non-attainment under an applicable federal or state ambient air quality standard (including releasing emissions which exceed quantitative thresholds for ozone precursors)?	<input type="checkbox"/>	<input type="checkbox"/>	<input checked="" type="checkbox"/>	<input type="checkbox"/>
d) Expose sensitive receptors to substantial pollutant concentrations?	<input type="checkbox"/>	<input type="checkbox"/>	<input checked="" type="checkbox"/>	<input type="checkbox"/>
e) Create objectionable odors affecting a substantial number of people?	<input type="checkbox"/>	<input type="checkbox"/>	<input type="checkbox"/>	<input checked="" type="checkbox"/>

SUMMARY OF IMPACTS IN PREVIOUS DOCUMENTS

- The ASR EIR/EA identified less than significant impacts during construction due to short-term emissions of PM10, exposures of sensitive receptors (e.g. Seaside Middle School) to elevated health risks from exposure to diesel particulates, and exposure of sensitive receptors to acrolein health hazards. No significant operational air quality impacts were identified.
- Addendum No. 1 to the ASR EIR/EA did not identify any significant impacts related to air quality resulting from construction or operation of ASR Phase 2.
- Addendum No. 2 to the ASR EIR/EA identified a potentially significant impact related to the exposure of sensitive receptors to pollutants during construction of the Hilby Pump Station. This impact could be mitigated to a less than significant level with the implementation of *Mitigation*

EXHIBIT 16-A

Initial Study Checklist Backflush Basin Expansion

*Measure AQ-1: Construction Fugitive Dust Control Plan*⁵ from the Pure Water Monterey Mitigation Monitoring and Reporting Plan.

- Addendum No. 3 to the ASR EIR/EA did not identify any significant impacts related to air quality resulting from the Monterey Pipeline Re-Alignment.

DISCUSSION

Emissions would be generated during construction of the Backflush Basin Expansion from the operation of construction equipment and site grading. No additional emissions would result from operation of the Proposed Project, as no additional mechanical or electrical equipment is necessary to operate the expanded backflush basin.

a) Less than Significant Impact: CEQA Guidelines Section 15125(b) requires that a project is evaluated for consistency with applicable regional plans, including the Air Quality Management Plan (AQMP). The MBARD is required to update their AQMP once every three years; the most recent update (MBARD, 2017) was approved in March of 2017. This plan addresses attainment of the State ozone standard and federal air quality standard. The AQMP accommodates growth by projecting growth in emissions based on population forecasts prepared by the Association of Monterey Bay Area Governments (AMBAG) and other indicators. Consistency determinations are issued for commercial, industrial, residential, and infrastructure related projects that have the potential to induce population growth. A project is considered inconsistent with the AQMP if it has not been accommodated in the forecast projections considered in the AQMP. The Proposed Backflush Basin Expansion would not cause and/or otherwise induce population growth. In addition, due to lack of operational emissions, it would not cause any long-term adverse air quality effects. As a result, the Proposed Project would not conflict with and/or otherwise obstruct the implementation of MBARD's AQMP. For these reasons, the Proposed Project would have a less than significant impact related to conflicts with air quality plans.

b, c) Less than Significant Impact: The MBARD 2016 CEQA Air Quality Guidelines (Guidelines) contains standards of significance for evaluating potential air quality effects of projects subject to the requirements of CEQA. According to MBARD, a project will not have a significant air quality effect on the environment, if the following criteria are met:

Construction of the project will:

- Emit (from all sources, including exhaust and fugitive dust) less than;
 - 137 pounds per day of oxides of nitrogen (NO_x);
 - 137 pounds per day of reactive organic gases (ROG);
 - 82 pounds per day of respirable particulate matter (PM₁₀);
 - 55 pounds per day of fine particulate matter (PM_{2.5}); and,
 - 550 pounds per day carbon monoxide (CO).

Operation of the project will:

⁵ Addenda No. 2 and No. 3 to the ASR EIR/EA were joint documents that amended both the ASR EIR/EA and the Pure Water Monterey Groundwater Replenishment Project (PWM) EIR. For this reason, mitigation measures from the PWM EIR were used to mitigate impacts resulting from those projects. However, the Proposed Backflush Basin Expansion covered under this Addendum are not subject to the PWM EIR or associated with this project; mitigation measures from the PWM EIR are not applicable to the Proposed Backflush Basin Expansion.

EXHIBIT 16-A

Initial Study Checklist Backflush Basin Expansion

- Emit (from all project sources, mobile, area, and stationary) less than;
 - 137 pounds per day of oxides of nitrogen (NO_x)
 - 137 pounds per day of reactive organic gases (ROG)
 - 82 pounds per day of PM₁₀
 - 55 pounds per day of PM_{2.5}
 - 550 pounds per day carbon monoxide (CO)
- Not cause or contribute to a violation of any California or National Ambient Air Quality Standard;
- Not result in a cumulatively considerable net increase of any criteria pollutant for with the project region is non-attainment;
- Not exceed the health risk public notification thresholds adopted by the MBARD;
- Not create objectionable odors affecting a substantial number of people; and,
- Be consistent with the adopted federal and state Air Quality Plans (MBAPCD, 2016).

The MBARD CEQA Guidelines for evaluating impacts during construction state that if a project generates less than 82lb/day of PM₁₀ emissions, the project is considered to have less than significant impacts (see Table 5-1, MBARD, 2016). The Guidelines also state that a project will result in less than significant impacts if daily ground-disturbing activities entail less than 8.1 acres of minimal earthmoving, or less than 2.2 acres of grading and excavation. Construction projects below these acreage thresholds would be below the applicable MBARD 82 lb/day threshold of significance and would constitute a less-than-significant effect for the purposes of CEQA (MBARD, 2016). The construction area of the Backflush Basin Expansion is approximately 1.9 acres, however, construction activities at any given time would occur on much less than 1.9 acres. Construction of the Backflush Basin Expansion would be below the threshold of 2.2 acres of daily grading. As a result, the Proposed Project would result in a less than significant construction-related air quality effect.

The proposed Backflush Basin Expansion would result in temporary increases in emissions of inhalable particulates (PM_{2.5} and PM₁₀), VOC, and NO_x associated with construction-related activities, see **Table 1. Construction Air Pollutant Emissions for the Backflush Basin Expansion** below for detailed information on these emissions. See **Attachment 2, Air Quality and GHG Calculations Spreadsheets** for more information. Construction-related fugitive dust emissions associated with the proposed Backflush Basin Expansion would be generated from the Proposed Project site grading and construction. In addition to construction-related fugitive dust, exhaust emissions associated with construction vehicles and equipment would also be generated.

The construction emissions generated by the Modifications would not overlap with construction of other components of the ASR Project because all physical components of that project have already have been constructed, therefore the emission associated with the construction of the Backflush Basin Expansion would not add to the construction emissions of the ASR Project, and would not increase the severity of Impacts AQ-1, AQ-2, AQ-3, AQ-4, or AQ-5 identified in the ASR EIR/EA. Construction of the Backflush Basin Expansion would last from August 2018 through October 2018. As shown in **Table 1. Construction Air Pollutant Emissions for the Backflush Basin Expansion**, construction of the Proposed Project would not exceed MBARD thresholds for emissions.

EXHIBIT 16-A

Initial Study Checklist
Backflush Basin Expansion

Table 1. Construction Air Pollutant Emissions for the Backflush Basin Expansion

	Emissions in Pounds/Day			
	NO _x	PM _{2.5}	PM ₁₀	ROG
Significance Threshold (MBARD)	137*	55	82	137*
Emissions generated by the Backflush Basin Expansion	0.5	0.1	0.2	0.0
Exceed Threshold?	No	No	No	No
Emissions Source: Attachment 2, Air Quality and GHG Calculations Spreadsheets Significance Threshold Source: MBARD, 2016 * Applies to non-typical construction equipment (i.e., well drilling) MBARD has identified that construction projects using typical construction equipment such as dump trucks, scrapers, bulldozers, compactors and front-end loaders that temporarily emit precursors of ozone (i.e., VOC or NO _x), are accommodated in the emission inventories of State- and federally-required air plans. Temporary emissions associated with the operation of construction equipment have been accommodated in State- and federally-required air plans				

The proposed Backflush Basin Expansion would not result in a new or substantially more severe significant impact due to air quality emissions during operations. Based upon the minimal level of operational emissions, operation of the Backflush Basin Expansion would not result in emissions that would result in any new significant impacts or cause an increase in severity of any significant impacts identified in the ASR EIR/EA based on an exceedance or violation of the applicable air quality standards.

d) Less than Significant Impact: The proposed Backflush Basin Expansion would be located on Fort Ord Reuse Authority (FORA) owned property, which is currently occupied with similar facilities. The nearest sensitive receptors to the site are approximately 190 feet to the west of the proposed driveway. The Proposed Project may create temporary construction dust given the proximity of the nearest residences. Implementation of the following standard construction best management practices (BMPs) would minimize temporary emissions from construction:

- Water all active construction areas as required with non-potable sources to the extent feasible; frequency should be based on the type of operation, soil, and wind exposure and minimized to prevent wasteful use of water and non-stormwater runoff.
- Prohibit grading activities during periods of high wind (over 15 mph).
- Cover all trucks hauling soil, sand, and other loose materials and require trucks to maintain at least 2 feet of freeboard.
- Hand sweep daily within paved areas.
- Sweep streets daily (with water sweepers) if visible soil material is carried onto adjacent public streets.
- Enclose, cover, or water daily exposed stockpiles (dirt, sand, aggregate, etc.).
- Replant vegetation in disturbed areas as quickly as possible.
- Provide stabilized construction entrances/exits to limit sediment tracking from the site.

With implementation of the above BMPs, construction of the proposed Backflush Basin Expansion would result in a less than significant impact to sensitive receptors.

e) No Impact. No substantial odors would be emitted from the proposed Backflush Basin Expansion site based upon the type of construction activities and project operations proposed.

EXHIBIT 16-A

Initial Study Checklist
Backflush Basin Expansion

CONCLUSION

The proposed Backflush Basin Expansion would not result in any new significant impacts or cause an increase in severity of any significant impacts identified in the ASR EIR/EA related to air quality resources.

4. Biological Resources

EXISTING SETTING

The proposed Backflush Basin Modification site is located on the Former Fort Ord on a site referred to as the Santa Margarita Site. Vegetation clearing, grading and excavation activities in support of the Backflush Basin Expansion would result in the modification/removal of two habitat types associated with the Santa Margarita Site. For the purposes of evaluation of biological resources, the total area of vegetation modification or removal is 0.9 acres⁶ (0.5 acres of maritime chaparral and 0.4 of ruderal vegetation).

Maritime Chaparral

Maritime chaparral is a shrub community dominated by moderate to low-growing evergreen and drought-deciduous shrubs adapted to shallow soils and periodic fires. The characteristic shrub species on the Proposed Project site include woollyleaf manzanita (*Arctostaphylos tomentosa*), chamise (*Adenostoma fasciculata*), deer broom (*Acmispon glaber*), bush monkeyflower (*Mimulus aurantiacus*), black sage (*Salvia mellifera*), and Monterey ceanothus (*Ceanothus cuneatus* var. *rigidus*). Several bird species feed and nest in chaparral habitat including orange-crowned warbler (*Vermivora celata*), spotted towhee (*Pipilo maculatus*), California thrasher (*Toxostoma redivivum*), and California quail (*Callipepla californica*) (Zeiner et al. 1990a). Mammals such as brush rabbit (*Sylvilagus bachmani*), California mouse (*Peromyscus californicus*) and brush mouse (*P. boylii*) will forage and find cover in dense chaparral, whereas narrow-faced kangaroo rat (*Dipodomys venustus*) and Heerman's kangaroo rat (*D. heermanni*) will use sparsely vegetated openings within thick vegetation (Zeiner et al., 1990b). These small mammals are preyed upon by gray fox (*Urocyon cinereoargenteus*), bobcat (*Felis rufus*), spotted skunk (*Spilogale gracilis*), and western rattlesnake (*Crotalis viridis*) (Zeiner et al. 1988, 1990b). Chaparral also provides important foraging habitat and cover for black-tailed deer (*Odocoileus hemionus*). Approximately 0.5 acres of maritime chaparral will be permanently removed from the Proposed Project site.

Ruderal Vegetation

A second plant community, ruderal vegetation, occurs between the fenced boundary between the former Fort Ord lands and residential area of Seaside and General Jim Moore Boulevard within the existing backflush basin and between the maritime chaparral and development associated with the City of Seaside. The ruderal community is disturbed and dominated by dense common Hottentot fig (*Carpobrotus edulis*). Approximately 0.4 acres of ruderal vegetation will be permanently removed from the Proposed Project site.

⁶ As previously stated in this document, the total potential area of disturbance is the entire Santa Margarita site, which is 1.9 acres.

EXHIBIT 16-A

Initial Study Checklist
Backflush Basin Expansion

CHECKLIST

	Potentially Significant Impact	Less than Significant with Mitigation Incorporated	Less than Significant Impact	No Impact
Would the project:				
a) Have a substantial adverse effect, either directly or through habitat modifications, on any species identified as a candidate, sensitive, or special status species in local or regional plans, policies, or regulations, or by the California Department of Fish and Game or U.S. Fish and Wildlife Service?	<input type="checkbox"/>	<input type="checkbox"/>	<input checked="" type="checkbox"/>	<input type="checkbox"/>
b) Have a substantial adverse effect on any riparian habitat or other sensitive natural community identified in local or regional plans, policies, regulations or by the California Department of Fish and Game or US Fish and Wildlife Service?	<input type="checkbox"/>	<input type="checkbox"/>	<input checked="" type="checkbox"/>	<input type="checkbox"/>
c) Have a substantial adverse effect on federally protected wetlands as defined by Section 404 of the Clean Water Act (including, but not limited to, marsh, vernal pool, coastal, etc.) through direct removal, filling, hydrological interruption, or other means?	<input type="checkbox"/>	<input type="checkbox"/>	<input type="checkbox"/>	<input checked="" type="checkbox"/>
d) Interfere substantially with the movement of any native resident or migratory fish or wildlife species or with established native resident or migratory wildlife corridors, or impede the use of native wildlife nursery sites?	<input type="checkbox"/>	<input type="checkbox"/>	<input type="checkbox"/>	<input checked="" type="checkbox"/>
e) Conflict with any local policies or ordinances protecting biological resources, such as a tree preservation policy or ordinance?	<input type="checkbox"/>	<input type="checkbox"/>	<input checked="" type="checkbox"/>	<input type="checkbox"/>
f) Conflict with the provisions of an adopted Habitat Conservation Plan, Natural Community Conservation Plan, or other approved local, regional, or state habitat conservation plan?	<input type="checkbox"/>	<input type="checkbox"/>	<input checked="" type="checkbox"/>	<input type="checkbox"/>

SUMMARY OF IMPACTS IN PREVIOUS DOCUMENTS

- The ASR EIR/EA identified less than significant impacts for removal and destruction of sensitive vegetation and potential direct mortality or disturbance of protected animal species. The ASR EIR/EA identified significant impacts related to potential disturbance of the Fort Ord Natural Resource Management Area (NRMA) and potential loss of nest trees and disturbance or mortality of migratory birds. *Mitigation Measures BIO-1: Minimize or Prevent Disturbance to Adjacent NMRA and BIO-2: Remove Trees and Shrubs during the Nonbreeding Season for Most Birds (September 1 To February 15)* was identified and implemented to reduce impacts to a less than significant level. The ASR EIR/EA noted that the ASR Project has the potential to affect special status aquatic species within the river corridor of the Carmel River, but has been designed to minimize any adverse impacts. *Mitigation Measures AR-1: Conduct Annual Survey Below River Mile 5.5 and Monitor River Flow in January-June Period, and AR-2: Cooperate to help develop a Project to Maintain, Recover, or Increase Storage in Los Padres Reservoir and If Needed, Continue Funding Program to Rescue and Rea Isolated Juveniles* were identified in the ASR EIR/EA in association with potential impacts to flows for upstream migration and potential impacts to juvenile steelhead rearing habitat. Potential benefits to steelhead and California red-legged frog

EXHIBIT 16-A

Initial Study Checklist Backflush Basin Expansion

include the reduction of groundwater pumping along the Carmel River in the dry summer months from the use of the Seaside Groundwater Basin for municipal supply. The net effect of these operational changes will likely increase streamflow and improve environmental conditions along the Carmel River. Thus, the ASR EIR/EA concluded that the ASR Project would be beneficial to steelhead and the California red-legged frog.

- Addendum No. 1 to the ASR EIR/EA did not identify any significant impacts to biological resources resulting from implementation of ASR Phase 2.
- Addendum No. 2 to the ASR EIR/EA identified a potentially significant impact during construction of the Hilby Pump Station related to impacts to Monterey spine flower, a federally threatened species. This impact could be reduced to less than significant levels with the implementation of *Mitigation Measure BT-1a: Implement Construction Best Management Practices from the Pure Water Monterey Mitigation Monitoring and Reporting Plan*.
- Addendum No. 3 to the ASR EIR/EA identified a potentially significant impact resulting from impacts to nesting birds during construction of the Monterey Pipeline. This impact could be mitigated to less than significant levels with the implementation of *Mitigation Measures BT-1a: Implement Construction Best Management Practices, BT-1k: Conduct Pre-Construction Surveys for Protected Avian Species, including, but not limited to, white-tailed kite and California horned lark, and, BT-1m: Minimize Effects of Nighttime Construction Lighting* from the Pure Water Monterey Mitigation Monitoring and Reporting Plan.

DISCUSSION

a) Less than Significant Impact: Vegetation removal for construction of the Backflush Basin Modification would result in the permanent loss of approximately 0.5 acres of maritime chaparral and 0.4 acres of ruderal vegetation.

Construction of the expanded backflush basin, driveway and fence has the potential to result in direct mortality or disturbance of California horned lizard and would result in permanent loss of approximately 0.9 acre of habitat capable of supporting California horned lizard. Although this species is known to occur on the former Fort Ord in small numbers (U.S. Army Corps of Engineers, 1992), it is common throughout the southern portion of the Central Coast Range and occurs in fair numbers throughout the rest of its range in California (Jennings and Hayes, 1994). Because the status of the California horned lizard in the region is relatively abundant, and because a very small area of habitat will be affected, and the species is unlikely to occur in significant numbers in this small area, this impact is considered less than significant.

Construction of the expanded backflush basin, driveway, and fence would result in permanent loss of up to 0.9 acre of habitat potentially containing Monterey spineflower, Sandmat manzanita, Eastwood's goldenbush, and Kellogg's horkelia. These species are scattered across the project site the actual area of plant disturbance cannot be determined. However, the plants are not distributed uniformly across the project site, so the impact would probably be less than 0.9 acre. These impacts are considered less than significant, because the United States Fish and Wildlife Service (USFWS) has determined that development of the borderland development areas would not have a substantial adverse effect on the populations at Fort Ord, if the Habitat Management Plan (HMP) is implemented. The HMP establishes guidelines for the conservation and management of species and habitats on former Fort Ord lands by identifying lands that are available for development, lands that have some restrictions with development, and habitat reserve areas.

EXHIBIT 16-A

Initial Study Checklist Backflush Basin Expansion

Construction of the expanded backflush basin, driveway, and fence has the potential to result in direct mortality or disturbance of black legless lizard and would result in permanent loss of approximately 0.9 acre of habitat capable of supporting black legless lizard. Direct mortality of black legless lizards and the permanent loss of habitat would be considered a significant impact because the subspecies is rare in California, with a distribution that is restricted to coastal areas in the Monterey Bay region (Stebbins 2003). However, development and implementation of the HMP has provided adequate mitigation for potential impacts to the black legless lizard. Therefore, this impact is less than significant.

Maritime chaparral present within and surrounding the Proposed Project site that provide suitable nesting habitat for migratory birds. Construction or removal of nest trees and shrubs during the nesting period for migratory birds could result in nest abandonment and death of young or loss of reproductive potential at active nests located in the Proposed Project site. Impacts on migratory birds would be considered adverse if the subsequent population decline was large and affected the viability of the local population. Because only a small area of habitat (shrubs within approximately 0.5 acre) will be impacted by the Proposed Project, impacts on migratory birds are considered less than significant.

In order to avoid violation of California Fish and Game Code Sections 3503 (active bird nests), a pre-construction survey by a qualified biologist for active nests would be conducted prior to construction. A qualified biologist shall be retained by the project proponents to conduct pre-construction surveys for nesting raptors and other protected avian species where nesting habitat is identified and within a suitable buffer area if construction commences between February 15 and September 1. Pre-construction surveys shall be conducted no more than 14 days prior to the start of construction activities during the early part of the breeding season (February through April) and no more than 30 days prior to the initiation of these activities during the late part of the breeding season (May through August). Because some bird species nest early in spring and others nest later in summer, surveys for nesting birds may be required to continue during construction to address new arrivals, and because some species breed multiple times in a season. The necessity and timing of these continued surveys shall be determined by the qualified biologist based on review of the final construction plans. If active raptor or other protected avian species nests are identified during the preconstruction surveys, the qualified biologist shall notify the project proponents and an appropriate no-disturbance buffer shall be imposed within which no construction activities or disturbance shall take place until the young have fledged and are no longer reliant upon the nest or parental care for survival, as determined by a qualified biologist.

Construction of the expanded backflush basin, driveway, and fence has the potential to result in direct mortality or disturbance of Monterey dusky-footed woodrat and would result in permanent loss of approximately 0.5 acre of habitat capable of supporting Monterey dusky-footed woodrat. Direct mortality of Monterey dusky-footed woodrat and the permanent and temporary loss of habitat would be considered a significant impact because the species is rare in California, with a distribution that is restricted to appropriate habitat in two California counties (CNDDB, 2005b). However, development and implementation of the HMP has provided adequate mitigation for potential impacts to the dusky-footed woodrat.

b) Less than Significant Impact: Construction of the expanded backflush basin, driveway, and fence would result in permanent loss of up to 0.5 acre of maritime chaparral. The project site is within the area designated for development under the Fort Ord HMP, which mitigates for the loss of maritime chaparral habitat through implementation of the Natural Resource Management Area (NRMA). This is consistent with the Draft ASR EIR/EA. Therefore, this impact is considered less than significant.

EXHIBIT 16-A

Initial Study Checklist
Backflush Basin Expansion

c) No Impact: There are no federally protected wetlands as defined by Section 404 of the Clean Water Act within the Proposed Project site therefore there are no impacts to this sensitive habitat as a result of the construction of the Backflush Basin Expansion.

d) No Impact: With the possible exception of nesting birds and raptors addressed in a) above, the project will not substantially interfere with the movement of any native resident or migratory fish or wildlife species or with established native resident or migratory wildlife corridors or impede the use of native wildlife nursery sites.

e, f) Less than Significant Impact: The proposed ASR Expansion would not conflict with local policies protecting biological resources. No tree removal would be associated with the Proposed Project. The Project site is located within the boundaries of the adopted HMP and is being constructed in compliance with the Conditions of the HMP. This is consistent with the Draft ASR EIR/EA.

CONCLUSION

The proposed Backflush Basin Expansion would not result in any new significant impacts or cause an increase in severity of any significant impacts identified in the ASR EIR/EA related to biological resources.

5. Cultural Resources

EXISTING SETTING

A records search at the Northwest Information Venter of the California Historical Resources Information System (CHRIS) was conducted in 2005 as part of the preparation of the ASR EIR/EA. A review of all of the archaeological sites and surveys within 0.5 mile of the site, historical maps, and the Historic Resources Index was performed. Additionally, historic maps for the site, the National Register of Historic Places, and the California Register of Historical Resources were consulted. The records search at CHRIS did not result in the identification of any previously recorded prehistoric or historic resources within 0.5 mile of the site. The closest prehistoric archaeological site, CA-MNT-699, is located in the coastal dunes.

CHECKLIST

	Potentially Significant Impact	Less than Significant with Mitigation Incorporated	Less than Significant Impact	No Impact
Would the project:				
a) Cause a substantial adverse change in the significance of a historical resource as defined in § 15064.5?	<input type="checkbox"/>	<input type="checkbox"/>	<input type="checkbox"/>	<input checked="" type="checkbox"/>
b) Cause a substantial adverse change in the significance of an archaeological resource pursuant to § 15064.5?	<input type="checkbox"/>	<input checked="" type="checkbox"/>	<input type="checkbox"/>	<input type="checkbox"/>
c) Directly or indirectly destroy a unique paleontological resource or site or unique geologic feature?	<input type="checkbox"/>	<input type="checkbox"/>	<input type="checkbox"/>	<input checked="" type="checkbox"/>
d) Disturb any human remains, including those interred outside of dedicated cemeteries?	<input type="checkbox"/>	<input checked="" type="checkbox"/>	<input type="checkbox"/>	<input type="checkbox"/>

EXHIBIT 16-A

Initial Study Checklist
Backflush Basin Expansion

SUMMARY OF IMPACTS IN PREVIOUS DOCUMENTS

- The ASR EIR/EA found a potentially significant impact due to the potential for discovery of buried unknown cultural deposits and human remains during construction activities; however, *Mitigation Measures CR-1: Stop Work If Buried Cultural Deposits Are Encountered during Construction Activities* and *CR-2: Stop Work If Human Remains are Encountered during Construction Activities*, were presented and adopted to reduce potential impacts to a less than significant level.
- Addendum No. 1 to the ASR/EA came to the same conclusion as the ASR EIR/EA. Potentially significant impacts could result from the potential for discovery of buried unknown cultural deposits and human remains during construction activities. These impacts could be reduced to less than significant with the implementation of *Mitigation Measures CR-1: Stop Work If Buried Cultural Deposits Are Encountered during Construction Activities* and *CR-2: Stop Work If Human Remains are Encountered during Construction Activities*.
- Addendum No. 2 to the ASR ER/EA also identified a potentially significant impact during construction of the Hilby Pump Station due to the potential for discovery of buried unknown cultural deposits and human remains during construction activities. These impacts could be reduced to less than significant with the implementation of *Mitigation Measures CR-1: Stop Work If Buried Cultural Deposits Are Encountered during Construction Activities* and *CR-2: Stop Work If Human Remains are Encountered during Construction Activities*.
- Addendum No. 3 to the ASR EIR/EA identified also identified a potentially significant impact during construction of the Monterey Pipeline Re-Alignment due to the potential for discovery of buried unknown cultural deposits and human remains during construction activities. These impacts could be reduced to less than significant with the implementation of *Mitigation Measures CR-1: Stop Work If Buried Cultural Deposits Are Encountered during Construction Activities* and *CR-2: Stop Work If Human Remains are Encountered during Construction Activities*.

DISCUSSION

a) No Impact: The proposed Backflush Basin Expansion would not impact historic resources; there are no documented historical resources on the Proposed Project site or in the vicinity.

b) Less than Significant Impact with Mitigation: Ground disturbing activities could potentially unearth unknown archaeological resources. However, the proposed Backflush Basin Expansion area has previously been surveyed for nearby and adjacent projects, and there is a low possibility of archaeological resources to be present at the Proposed Project site. While previously unknown or buried archaeological resources are not anticipated to be encountered during project construction, the implementation of **Mitigation Measures CR-1: Stop Work If Buried Cultural Deposits Are Encountered during Construction and CR-2: Stop Work If Human Remains Are Encountered during Construction Activities**, previously approved as part of the ASR EIR/EA and described below, would ensure that potential impacts due to the discovery of previously unknown archaeological resources would be less than significant. As a result, the Backflush Basin Expansion would not result in any new or substantially more severe significant impacts beyond those identified in the ASR EIR/EA. No additional mitigation would be necessary beyond those measures already identified and provided below.

c) No Impact: Based on lack of previously identified paleontological resources on the site or in the vicinity, there are no known paleontological resources on the Backflush Basin Modification site that would be disturbed by implementation of the Proposed Project.

EXHIBIT 16-A

Initial Study Checklist
Backflush Basin Expansion

d) Less than Significant Impact with Mitigation: Implementation of the Backflush Basin Expansion would not be expected to disturb human remains based upon lack of previously identified human remains on the site and in the vicinity. In the unlikely event that human remains are discovered during earthmoving activities, **Mitigation Measures CR-1: Stop Work If Buried Cultural Deposits Are Encountered during Construction and CR-2: Stop Work If Human Remains Are Encountered during Construction Activities**, previously approved as part of the ASR EIR/EA and described below, would reduce the potential impact to a less than significant level, included in **Attachment 4**. The Proposed Project would not result in any new or more severe significant impacts than those identified in the ASR EIR/EA. No additional mitigation would be necessary beyond those identified.

MITIGATION MEASURES

Mitigation Measure CR-1: Stop Work If Buried Cultural Deposits Are Encountered during Construction Activities.

If buried cultural resources such as chipped stone or groundstone, historic debris, building foundations, or human bone are inadvertently discovered during ground-disturbing activities, the construction contractor will stop work in that area and within a 100-foot radius of the find until a qualified archaeologist can assess the significance of the find and, if necessary, develop appropriate treatment measures. Treatment measures typically include avoidance strategies or mitigation of impacts through data recovery programs such as excavation or detailed documentation.

Mitigation Measure CR-2: Stop Work If Human Remains Are Encountered during Construction Activities.

If human skeletal remains are encountered, the construction contractor will notify CalAm and the county coroner immediately. CalAm will ensure the construction specifications include this order.

If the county coroner determines that the remains are Native American, the coroner will be required to contact the NAHC (pursuant to Section 7050.5 [c] of the California Health and Safety Code) and the County Coordinator of Indian Affairs. A qualified archaeologist will also be contacted immediately.

If human remains are discovered in any location other than a dedicated cemetery, there will be no further excavation or disturbance of the site or any nearby area reasonably suspected to overlie adjacent human remains until:

- the coroner of the county has been informed and has determined that no investigation of the cause of death is required; and
- if the remains are of Native American origin:
 - the descendants from the deceased Native Americans have made a recommendation to the landowner or the person responsible for the excavation work for means of treating or disposing of with appropriate dignity the human remains, and any associated grave goods as provided in Public Resources Code Section 5097.98; or
 - the NAHC was unable to identify a descendent or the descendent failed to make a recommendation within 24 hours after being notified by the commission.

According to the California Health and Safety Code, six or more human burials at one location constitute a cemetery (Section 8100), and disturbance of Native American cemeteries is a felony (Section 7052). Section 7050.5 requires that construction or excavation be stopped in the vicinity of discovered human

EXHIBIT 16-A

Initial Study Checklist
Backflush Basin Expansion

remains until the coroner can determine whether the remains are those of a Native American. If the remains are determined to be Native American, the coroner must contact the NAHC.

CONCLUSION

The proposed Backflush Basin Expansion would not result in any new significant impacts or cause an increase in severity of any significant impacts identified in the ASR EIR/EA related to cultural resources. Because the Modifications could potentially contribute to previously identified significant impacts to unknown cultural resources, **Mitigation Measures CR-1: Stop Work If Buried Cultural Deposits Are Encountered during Construction and CR-2: Stop Work If Human Remains Are Encountered during Construction Activities** from the previously approved ASR EIR/EA must be implemented.

6. Geology and Soils

EXISTING SETTING

Pueblo Water Resources prepared a Geotechnical Investigation for the Santa Margarita site in 2009 in preparation for construction of the existing electrical building. They evaluated the proposed Backflush Basin Expansion in an Update Letter to the Geological Investigation dated February 4, 2018. The proposed Backflush Basin Expansion site is located on older coastal dunes. Older coastal dunes are described as weakly consolidated, poorly grading fine to medium grained sand deposits (Pueblo Water Resources, 2009).

CHECKLIST

	Potentially Significant Impact	Less than Significant with Mitigation Incorporated	Less than Significant Impact	No Impact
Would the project:				
a) Expose people or structures to potential substantial adverse effects, including the risk of loss, injury, or death involving:	<input type="checkbox"/>	<input type="checkbox"/>	<input checked="" type="checkbox"/>	<input type="checkbox"/>
i) Rupture of a known earthquake fault, as delineated on the most recent Alquist-Priolo Earthquake Fault Zoning Map issued by the State Geologist for the area or based on other substantial evidence of a known fault? Refer to Division of Mines and Geology Special Publication 42.	<input type="checkbox"/>	<input type="checkbox"/>	<input checked="" type="checkbox"/>	<input type="checkbox"/>
ii) Strong seismic ground shaking?	<input type="checkbox"/>	<input type="checkbox"/>	<input checked="" type="checkbox"/>	<input type="checkbox"/>
iii) Seismic-related ground failure, including liquefaction?	<input type="checkbox"/>	<input type="checkbox"/>	<input checked="" type="checkbox"/>	<input type="checkbox"/>
iv) Landslides?	<input type="checkbox"/>	<input type="checkbox"/>	<input checked="" type="checkbox"/>	<input type="checkbox"/>
b) Result in substantial soil erosion or the loss of topsoil?	<input type="checkbox"/>	<input type="checkbox"/>	<input checked="" type="checkbox"/>	<input type="checkbox"/>
c) Be located on a geologic unit or soil that is unstable, or that would become unstable as a result of the project, and potentially result in on-or off-site landslide, lateral spreading, subsidence, liquefaction or collapse?	<input type="checkbox"/>	<input type="checkbox"/>	<input checked="" type="checkbox"/>	<input type="checkbox"/>
d) Be located on expansive soil, as defined in Table 18-1-B of the Uniform Building Code (1994), creating substantial risks to life or property?	<input type="checkbox"/>	<input type="checkbox"/>	<input type="checkbox"/>	<input checked="" type="checkbox"/>

EXHIBIT 16-A

Initial Study Checklist
Backflush Basin Expansion

Would the project:	Potentially Significant Impact	Less than Significant with Mitigation Incorporated	Less than Significant Impact	No Impact
e) Have soils incapable of adequately supporting the use of septic tanks or alternative waste water disposal systems where sewers are not available for the disposal of waste water?	<input type="checkbox"/>	<input type="checkbox"/>	<input type="checkbox"/>	<input checked="" type="checkbox"/>

SUMMARY OF IMPACTS IN PREVIOUS DOCUMENTS

- The ASR EIR/EA found that all geologic, soils, and seismicity impacts of the ASR Project would be less than significant.
- Addendum No. 1 to the ASR EIR/EA did not identify any significant impacts related to geology and soils.
- Addendum No. 2 did not identify any significant impact related to geology and soils resulting from the construction or operation of the Hilby Pump Station.
- Addendum No. 3 did not identify any significant impact related to geology and soils resulting from the Monterey Pipeline Re-Alignment.

DISCUSSION

a, b, c) Less than Significant Impact: The 2009 Geotechnical Investigation completed by Pueblo Water Resources included as **Attachment 3**, found that it is reasonable to assume that the site will experience significant seismic shaking during the lifetime of the Proposed Project. Since the nearest known active or potentially active fault is mapped approximately 3.6 miles from the site, the potential for ground surface fault rupture is low. Based on review done by Pueblo Water Resources of regional liquefaction maps, the site is located in an area classified as having a low potential for liquefaction. In addition, groundwater was not encountered within the upper 36 feet of the site. Analysis done by Pueblo Water Resources showed that the potential for liquefaction and lateral spreading is low. There is also a low probability for seismically induced landsliding because the site is relatively flat. All recommendations included in the 2009 Geotechnical Investigation and the 2018 Update Letter would be incorporated into the Proposed Project.

d, e) No Impact: The proposed Backflush Basin Expansion site is not located on expansive soils and does not involve septic or alternative wastewater disposal systems.

CONCLUSION

The proposed Backflush Basin Expansion would not result in any new significant impacts or cause an increase in severity of any significant impacts identified in the ASR EIR/EA related to geology and soils.

7. Greenhouse Gas Emissions

EXISTING SETTING

Global temperatures are affected by naturally occurring and anthropogenic-generated atmospheric gases, such as water vapor, carbon dioxide, methane, and nitrous oxide (Intergovernmental Panel on Climate Change, 2007). Gases that trap heat in the atmosphere are called greenhouse gases (GHGs). Solar

EXHIBIT 16-A

Initial Study Checklist
Backflush Basin Expansion

radiation enters the earth’s atmosphere from space, and a portion of the radiation is absorbed at the surface. The earth emits this radiation back toward space as infrared radiation. Greenhouse gases, which are mostly transparent to incoming solar radiation, are effective in absorbing infrared radiation and redirecting some of this back to the earth’s surface. As a result, this radiation that otherwise would have escaped back into space is now retained, resulting in a warming of the atmosphere. This is known as the greenhouse effect. The greenhouse effect helps maintain a habitable climate. Emissions of GHGs from human activities, such as electricity production, motor vehicle use, and agriculture, are elevating the concentration of GHGs in the atmosphere, and are reported to have led to a trend of unnatural warming of the earth’s natural climate, known as global warming or global climate change.

Climate change is a cumulative impact; a project contributes to this impact through its incremental contribution of GHG emissions combined with the cumulative increase of all other sources of GHGs. The MBARD’s GHG threshold is defined in terms of carbon dioxide equivalent (CO2e), a metric that accounts for the emissions from various GHGs based on their global warming potential. If annual emissions of GHGs exceed these threshold levels, the proposed project would result in a cumulatively considerable contribution of GHG emissions and must implement mitigation measures.

CHECKLIST

	Potentially Significant Impact	Less than Significant with Mitigation Incorporated	Less than Significant Impact	No Impact
Would the project:				
a) Generate greenhouse gas emissions, either directly or indirectly, that may have a significant impact on the environment?	<input type="checkbox"/>	<input type="checkbox"/>	<input checked="" type="checkbox"/>	<input type="checkbox"/>
b) Conflict with an applicable plan, policy or regulation adopted for the purpose of reducing the emissions of greenhouse gases?	<input type="checkbox"/>	<input type="checkbox"/>	<input type="checkbox"/>	<input checked="" type="checkbox"/>

SUMMARY OF IMPACTS IN PREVIOUS DOCUMENTS

- The ASR EIR/EA did not contain an analysis of GHG emissions and climate change, because at the time the ASR EIR/EA was prepared, AB32, the Global Warming Solutions Act and associated updates to the CEQA statutes and guidelines were not in effect. Although an analysis of potential climate change impacts was not completed as part of the ASR EIR/EA, air quality modeling was completed for temporary construction phase impacts. All potential air quality related effects associated with the ASR Project were considered less than significant due to the temporary nature of project emissions.
- Addendum No. 1 to the ASR EIR/EA did not identify any significant impacts related to the generation of GHGs resulting from the implementation of ASR Phase 2.
- Addendum No. 2 to the ASR EIR/EA did not identify any significant impacts related to the generation of GHGs during construction of the Hilby Pump Station.
- Addendum No. 3 to the ASR EIR/EA did not identify a significant impact related to the generation of GHGs resulting from the Monterey Pipeline Re-Alignment.

EXHIBIT 16-A

Initial Study Checklist
Backflush Basin Expansion

DISCUSSION

a) Less Than Significant Impact: The MBARD has determined that if a project emits less than 10,000 metric tons per year (MT/yr) CO₂e that its impact will be less than significant. This calculation is made by combining the estimated greenhouse gas emissions generated by construction, amortized over a 30-year period, with the estimated annual GHG emissions resulting from operation of the project.

Construction of the Proposed Project would result in a one-time emission total of up to 39.2 MT/yr of CO₂e during the 3-month construction period; therefore, the annual amortized GHG emissions for the construction phase is 1.3 MT/year. The estimated annual greenhouse gas emissions generated by operation of the Proposed Project would be approximately 976.1 MT/year. Therefore, the estimated annual emissions for the entire project is 977.4 MT/year. This falls well below the threshold of 10,000 MT/year and is therefore considered to be less than significant.

b) No Impact: The proposed Backflush Basin Expansion would not conflict with any plan, policies, or regulations adopted for the purpose of reducing greenhouse gas emissions. AB32 recommends conjunctive groundwater use projects, such as ASR, as a key strategy for reducing the demand for more energy intensive water supply sources.

CONCLUSION

The proposed Backflush Basin Expansion would not result in any new significant impacts or cause an increase in severity of any significant impacts identified in the ASR EIR/EA related to greenhouse gas emissions.

8. Hazards and Hazardous Materials

EXISTING SETTING

A search of the California Department of Toxic Substances Control, EnviroStor database shows that the site is located on the former Fort Ord, which is an active superfund site pursuant to Government Code Section 65962.5. The Proposed Project site occupies land that was historically used for military training. Because of the former military use at the project site, munition response action was completed to remove Department of Defense (DoD) military munitions, many of which were determined upon evaluation by qualified personnel to be Munitions and Explosives of Concern (MEC). Even with completion of munitions response actions, there is potential for munitions to be encountered. The probability of encountering MEC at the Proposed Project site is considered low (Arcadis, Inc./Weston Solutions, Inc., 2018). No other contaminated cleanup sites are located within the vicinity of the Proposed Project Site (California Department of Toxic Substances Control, 2016). Seaside Middle School is located approximately 0.2 miles from the Proposed Project Site.

EXHIBIT 16-A

Initial Study Checklist
Backflush Basin Expansion

CHECKLIST

	Potentially Significant Impact	Less than Significant with Mitigation Incorporated	Less than Significant Impact	No Impact
Would the project:				
a) Create a significant hazard to the public or the environment through the routine transport, use, or disposal of hazardous materials?	<input type="checkbox"/>	<input type="checkbox"/>	<input checked="" type="checkbox"/>	<input type="checkbox"/>
b) Create a significant hazard to the public or the environment through reasonably foreseeable upset and accident conditions involving the release of hazardous materials into the environment?	<input type="checkbox"/>	<input type="checkbox"/>	<input checked="" type="checkbox"/>	<input type="checkbox"/>
c) Emit hazardous emissions or handle hazardous or acutely hazardous materials, substances, or waste within one-quarter mile of an existing or proposed school?	<input type="checkbox"/>	<input type="checkbox"/>	<input checked="" type="checkbox"/>	<input type="checkbox"/>
d) Be located on a site which is included on a list of hazardous materials sites compiled pursuant to Government Code Section 65962.5 and, as a result, would it create a significant hazard to the public or the environment?	<input type="checkbox"/>	<input checked="" type="checkbox"/>	<input type="checkbox"/>	<input type="checkbox"/>
e) For a project located within an airport land use plan or, where such a plan has not been adopted, within two miles of a public airport or public use airport, would the project result in a safety hazard for people residing or working in the project area?	<input type="checkbox"/>	<input type="checkbox"/>	<input type="checkbox"/>	<input checked="" type="checkbox"/>
f) For a project within the vicinity of a private airstrip, would the project result in a safety hazard for people residing or working in the project area?	<input type="checkbox"/>	<input type="checkbox"/>	<input type="checkbox"/>	<input checked="" type="checkbox"/>
g) Impair implementation of or physically interfere with an adopted emergency response plan or emergency evacuation plan?	<input type="checkbox"/>	<input type="checkbox"/>	<input checked="" type="checkbox"/>	<input type="checkbox"/>
h) Expose people or structures to a significant risk of loss, injury or death involving wildland fires, including where wildlands are adjacent to urbanized areas or where residences are intermixed with wildlands?	<input type="checkbox"/>	<input type="checkbox"/>	<input checked="" type="checkbox"/>	<input type="checkbox"/>

SUMMARY OF IMPACTS IN PREVIOUS DOCUMENTS

- The ASR EIR/EA evaluated hazardous materials impacts of the project and concluded there to be a potentially significant impact related to construction activities occurring on portions of the former Fort Ord associated with historic military use. *Mitigation Measure HAZ-1: Implement MEC Safety Precautions during Grading and Construction Activities at the Project Site* was identified to reduce the potential impact to a less than significant level. The ASR EIR/EA identified less than significant impacts associated with handling of associated materials and public exposure to contaminated drinking water.
- Addendum No. 1 to the ASR EIR/EA did not identify any potentially significant impacts related to hazards and hazardous materials.
- Addendum No. 2 to the ASR EIR/EA did not identify any potentially significant impacts related to hazards and hazardous materials from the construction or operation of the Hilby Pump Station.

EXHIBIT 16-A

Initial Study Checklist Backflush Basin Expansion

- Addendum No. 3 to the ASR EIR/EA did not identify any potentially significant impacts related to hazards and hazardous materials from the implementation of the Monterey Pipeline Re-Alignment.

DISCUSSION

a, b) Less than Significant Impact: No hazardous materials are expected to be stored onsite during operation of the Proposed Project. During construction, typical construction equipment fluids, including gasoline, diesel, and lubricants for maintaining equipment may be stored onsite. These materials would be handled and stored in compliance with all local, State, and Federal regulations pertaining to hazardous materials. This would constitute a less than significant impact resulting from the routine transport, use, or disposal of hazardous materials and potential release of hazardous materials.

c) Less than Significant Impact: The proposed Backflush Basin Expansion are located approximately 0.2 miles from Seaside Middle School. However, construction and implementation of the Proposed Project would not result in exposure of the students or staff to hazardous materials, substances, or wastes. All applicable regulations and policies relevant to hazardous materials transportation and storage would be adhered to. This is a less than significant impact.

d) Less than Significant Impact with Mitigation: The Proposed Project site is located within an area that formerly contained live-firing ranges for various weapons, therefore soil disturbance from excavating and grading activities could expose construction workers to hazards. This impact could be reduced to a less than significant level with the implementation of **Mitigation Measure HAZ-1: Implement MED Safety Precautions during Grading and Construction Activities at the Project Site**, included in **Attachment 4**

e, f) No Impact: The Proposed Backflush Basin Expansion are not located within two miles of a municipal or private airport. Therefore, no impacts would result due to airport related safety hazards.

g) Less than Significant Impact: Implementation of the proposed Backflush Basin Expansion would not interfere with evacuation plans because it involves no construction or operational activities that would fully block transportation pathways.

h) Less than Significant Impact: The project site is primarily surrounded by undeveloped lands. While there is potential for wildland fires in such a land use type, the Proposed Project would not increase the risk of wildfires to residents because construction of the Project would not involve any equipment or activities that present a severe fire risk. Implementation of the Proposed Project would not further expose people or structures to wildland fires.

MITIGATION MEASURE

Mitigation Measure HAZ-1: Implement MEC Safety Precautions during Grading and Construction Activities at the Project Site.

Because of the Proposed Project's location, the following safety precautions are required for onsite activities. The requirements may be modified upon completion of the Munitions Response Remedial Investigation/Feasibility Study (MR RI/FA) process for the munitions response sites.

- All personnel accessing the proposed site will be training in MEC recognition. This safety training is provided by the Army at no cost to the trainee.

EXHIBIT 16-A

Initial Study Checklist
Backflush Basin Expansion

- If an item is discovered that is or could be MEC, it shall not be disturbed. The item shall be reported immediately to the Presidion of Monterey Police Department at 831-242-7851 so that appropriate U.S. Military explosive ordinance disposal personnel can be dispatched to address such MEC as required under applicable law and regulations at the expense of the Army.
- Ground disturbing activities, including perimeter fence installation, will be coordinated with the U.S. Army Corps of Engineers Unexploded Ordinance Safety Specialist so that appropriate construction-related precautions may be provided.

CONCLUSION

The proposed Backflush Basin Expansion would not result in any new significant impacts or cause an increase in severity of any significant impacts identified in the ASR EIR/EA related to hazards and hazardous materials. Because the Modifications could potentially contribute to previously identified significant impacts to related to hazardous materials, **Mitigation Measure HAZ-1: Implement MEC Safety Precautions during Grading and Construction Activities at the Project Site**, above from the previously approved ASR EIR/EA must be implemented.

9. Hydrology and Water Quality

EXISTING SETTING

The proposed Backflush Basin Expansion site is sloped with an elevation of approximately 331 feet above sea level at the northwest side of the site, and an elevation of approximately 360 feet above sea level on the northeast side of the site. The elevation at the bottom of the existing backflush basin is approximately 329 feet above sea level. The majority of the Proposed Project site is pervious surface. Storm runoff from the Project site currently is directed into the existing backflush basin. The Project site does not contain any natural drainages or waterways.

CHECKLIST

	Potentially Significant Impact	Less than Significant with Mitigation Incorporated	Less than Significant Impact	No Impact
Would the project:				
a) Violate any water quality standards or waste discharge requirements?	<input type="checkbox"/>	<input type="checkbox"/>	<input type="checkbox"/>	<input checked="" type="checkbox"/>
b) Substantially deplete groundwater supplies or interfere substantially with groundwater recharge such that there would be a net deficit in aquifer volume or a lowering of the local groundwater table level (e.g., the production rate of pre-existing nearby wells would drop to a level which would not support existing land uses or planned uses for which permits have been granted)?	<input type="checkbox"/>	<input type="checkbox"/>	<input type="checkbox"/>	<input checked="" type="checkbox"/>
c) Substantially alter the existing drainage pattern of the site or area, including through the alteration of the course of a stream or river, in a manner which would result in substantial erosion or siltation on- or off-site?	<input type="checkbox"/>	<input type="checkbox"/>	<input checked="" type="checkbox"/>	<input type="checkbox"/>

EXHIBIT 16-A

Initial Study Checklist
Backflush Basin Expansion

Would the project:	Potentially Significant Impact	Less than Significant with Mitigation Incorporated	Less than Significant Impact	No Impact
d) Substantially alter the existing drainage pattern of the site or area, including through the alteration of the course of a stream or river, or substantially increase the rate or amount of surface runoff in a manner which would result in flooding on- or off-site?	<input type="checkbox"/>	<input type="checkbox"/>	<input checked="" type="checkbox"/>	<input type="checkbox"/>
e) Create or contribute runoff water which would exceed the capacity of existing or planned stormwater drainage systems or provide substantial additional sources of polluted runoff?	<input type="checkbox"/>	<input type="checkbox"/>	<input checked="" type="checkbox"/>	<input type="checkbox"/>
f) Otherwise substantially degrade water quality?	<input type="checkbox"/>	<input type="checkbox"/>	<input type="checkbox"/>	<input checked="" type="checkbox"/>
g) Place housing within a 100-year flood hazard area as mapped on a federal Flood Hazard Boundary or Flood Insurance Rate Map or other flood hazard delineation map?	<input type="checkbox"/>	<input type="checkbox"/>	<input type="checkbox"/>	<input checked="" type="checkbox"/>
h) Place within a 100-year flood hazard area structures which would impede or redirect flood flows?	<input type="checkbox"/>	<input type="checkbox"/>	<input type="checkbox"/>	<input checked="" type="checkbox"/>
i) Expose people or structures to a significant risk of loss, injury or death involving flooding, including flooding as a result of the failure of a levee or dam?	<input type="checkbox"/>	<input type="checkbox"/>	<input type="checkbox"/>	<input checked="" type="checkbox"/>
j) Inundation by seiche, tsunami, or mudflow?	<input type="checkbox"/>	<input type="checkbox"/>	<input type="checkbox"/>	<input checked="" type="checkbox"/>

SUMMARY OF IMPACTS IN PREVIOUS DOCUMENTS

- The ASR EIR/EA identified less than significant and beneficial hydrology and water quality impacts of the ASR project.
- Addendum No. 1 to the ASR EIR/EA did not identify any significant impacts related to hydrology and water quality resulting from the implementation of ASR Phase 2.
- Addendum No. 2 to the ASR EIR/EA did not identify any significant impacts related to hydrology and water quality resulting from the construction or operation of the Hilby Pump Station.
- Addendum No. 3 to the ASR EIR/EA did not identify any significant impacts related to hydrology and water quality resulting from implementation of the Monterey Pipeline Re-Alignment.

DISCUSSION

a) Less Than Significant Impact: The proposed Backflush Basin Expansion would be subject to the National Pollutant Discharge Elimination System (NPDES) Construction General Permit and the Municipal Stormwater Permit requirements (including the preparation of a Stormwater Pollution Prevention Plan or SWPPP). MPWMD and their contractors will comply with all applicable water quality standards and waste discharge requirements.

b) No Impact: The proposed Backflush Basin Expansion would not deplete groundwater supplies, as it is a component of an aquifer recovery system. In fact, it would provide a greater opportunity for water to percolate into the Seaside Groundwater Basin.

c, d, e,) Less than Significant Impact: Implementation of the proposed Backflush Basin Expansion would change the drainage pattern at the Santa Margarita site; proposed grading would change the contour of

EXHIBIT 16-A

Initial Study Checklist Backflush Basin Expansion

the site and excavate a larger backflush basin to allow for greater percolation. These changes would not, however, increase the amount of erosion or surface runoff in a manner which would result in flooding on- or off-site because all backflush water generated by the ASR wells would remain onsite and would be allowed to percolate into the groundwater in the proposed backflush basin. The Proposed Project would not exceed the capacity of existing or planned stormwater drainage systems because all water generated by the ASR wells would remain onsite.

f, g, h, i, j) No Impact: The Proposed Project would not degrade water quality, as it is a water infrastructure project. The proposed Backflush Basin Expansion site does not contain drainages, floodways, or floodplain areas according to the Flood Insurance Rate Maps (FIRM) applicable to the Proposed Project site (FEMA, 2009). The proposed Backflush Basin Expansion does not include residential housing. The proposed Backflush Basin Expansion site is not located within a flood hazard zone, near a dam or levee structure, or located in an area subject to significant seiche, tsunami, or mudflow risk (Monterey County, 2010b and 2010c).

CONCLUSION

The proposed Backflush Basin Expansion would not result in any new significant impacts or cause an increase in severity of any significant impacts identified in the ASR EIR/EA related to hydrology and water quality.

10. Land Use and Planning

EXISTING SETTING

The proposed Backflush Basin Expansion site is located on Monterey County Assessor Parcel Number (APN) 031-211-001-000 and is owned by Fort Ord Reuse Authority (FORA). The site is also designated as parcel E34 by the U.S. Army Corps of Engineers. It is designated as Low Density Single Family Residential (RLS) in the City of Seaside General Plan (City of Seaside, 2003) and is zoned as Single Family Residential (RS-8) in the City of Seaside Zoning District Map (City of Seaside, 2010).

CHECKLIST

	Potentially Significant Impact	Less than Significant with Mitigation Incorporated	Less than Significant Impact	No Impact
Would the project:				
a) Physically divide an established community?	<input type="checkbox"/>	<input type="checkbox"/>	<input type="checkbox"/>	<input checked="" type="checkbox"/>
b) Conflict with any applicable land use plan, policy, or regulation of an agency with jurisdiction over the project (including, but not limited to the general plan, specific plan, local coastal program, or zoning ordinance) adopted for the purpose of avoiding or mitigating an environmental effect?	<input type="checkbox"/>	<input type="checkbox"/>	<input checked="" type="checkbox"/>	<input type="checkbox"/>
c) Conflict with any applicable habitat conservation plan or natural community conservation plan?	<input type="checkbox"/>	<input type="checkbox"/>	<input checked="" type="checkbox"/>	<input type="checkbox"/>

EXHIBIT 16-A

Initial Study Checklist
Backflush Basin Expansion

SUMMARY OF IMPACTS IN PREVIOUS DOCUMENTS

- The ASR EIR/EA identified less than significant impacts associated with land use compatibility.
- Addendum No. 1 to the ASR EIR/EA did not identify any additional significant impacts related to land use and planning resulting from implementation of ASR Phase 2.
- Addendum No. 2 to the ASR EIR/EA did not identify any additional significant impacts related to land use and planning resulting from construction or operation of the Hilby Pump Station.
- Addendum No. 3 to the ASR EIR/EA did not identify any additional significant impacts related to land use and planning resulting from the implementation of the Monterey Pipeline Re-Alignment.

DISCUSSION

a) No Impact: Implementation of the proposed Backflush Basin Expansion would not physically divide an established community. The existing facilities and proposed facilities will be contained within a single parcel along an existing roadway.

b) Less than Significant Impact: The proposed Backflush Basin Expansion property is designated by the City of Seaside General Plan as Low Density Single Family Residential and the installation of public utility infrastructure would be a compatible use. The Backflush Basin Expansion would not conflict with any applicable land use plan, policy, or regulation of an agency with jurisdiction over the project and City of Seaside policies and ordinances would be adhered to. The Backflush Basin Expansion would not conflict with existing uses. Construction activities would be temporary in nature and would not result in any additional impacts beyond those previously identified in connection with the ASR project.

c) Less than Significant Impact: The proposed Backflush Basin Expansion site is located with the boundary of the Fort Ord HMP, for more information on the HMP, see Section 4. Biological Resources. Construction and operation of the proposed re-alignment would not conflict with the measures included in the HMP.

CONCLUSION

The proposed Backflush Basin Expansion would not result in any new significant impacts or cause an increase in severity of any significant impacts identified in the ASR EIR/EA related to land use and planning.

11. Mineral Resources

EXISTING SETTING

The proposed Backflush Basin Expansion site is not located in an area containing mineral resources, therefore a discussion of the existing setting is not included.

CHECKLIST

	Potentially Significant Impact	Less than Significant with Mitigation Incorporated	Less than Significant Impact	No Impact
Would the project:				
a) Result in the loss of availability of a known mineral resource that would be of value to the region and the residents of the state?	<input type="checkbox"/>	<input type="checkbox"/>	<input type="checkbox"/>	<input checked="" type="checkbox"/>

EXHIBIT 16-A

Initial Study Checklist
Backflush Basin Expansion

Would the project:	Potentially Significant Impact	Less than Significant with Mitigation Incorporated	Less than Significant Impact	No Impact
b) Result in the loss of availability of a locally important mineral resource recovery site delineated on a local general plan, specific plan or other land use plan?	<input type="checkbox"/>	<input type="checkbox"/>	<input type="checkbox"/>	<input checked="" type="checkbox"/>

SUMMARY OF IMPACTS IN PREVIOUS DOCUMENTS

- No potential impacts to mineral resources were identified in the ASR EIR/EA.
- No potential impacts to mineral resources were identified in Addendum No. 1 to the ASR EIR/EA resulting from the implementation of ASR Phase 2.
- No potential impacts to mineral resources were identified in Addendum No. 2 to the ASR EIR/EA resulting from construction or operation of the Hilby Pump Station.
- No potential impacts to mineral resources were identified in Addendum No. 3 to the ASR EIR/EA resulting from the implementation of the Monterey Pipeline Re-Alignment.

DISCUSSION

a, b) No Impact: The proposed Backflush Basin Expansion site is not located in an area of potential mineral resources; the proposed Backflush Basin Expansion would not impact mineral resources.

CONCLUSION

The proposed Backflush Basin Expansion would not result in any new significant impacts or cause an increase in severity of any significant impacts identified in the ASR EIR/EA related to mineral resources.

12. Noise

EXISTING SETTING

The Proposed Project site is located within an existing water infrastructure site, which is located adjacent to open space and a residential neighborhood. There are currently motors associated with the existing ASR wells currently in operation at the Santa Margarita site, which generate a minimal amount of noise. The closest residences to the proposed Backflush Basin Expansion site are located approximately 190 feet from the proposed driveway.

CHECKLIST

Would the project result in:	Potentially Significant Impact	Less than Significant with Mitigation Incorporated	Less than Significant Impact	No Impact
a) Exposure of persons to or generation of noise levels in excess of standards established in the local general plan or noise ordinance, or applicable standards of other agencies?	<input type="checkbox"/>	<input type="checkbox"/>	<input checked="" type="checkbox"/>	<input type="checkbox"/>

EXHIBIT 16-A

Initial Study Checklist
Backflush Basin Expansion

	Potentially Significant Impact	Less than Significant with Mitigation Incorporated	Less than Significant Impact	No Impact
Would the project result in:				
b) Exposure of persons to or generation of excessive groundborne vibration or groundborne noise levels?	<input type="checkbox"/>	<input type="checkbox"/>	<input checked="" type="checkbox"/>	<input type="checkbox"/>
c) A substantial permanent increase in ambient noise levels in the project vicinity above levels existing without the project?	<input type="checkbox"/>	<input type="checkbox"/>	<input type="checkbox"/>	<input checked="" type="checkbox"/>
d) A substantial temporary or periodic increase in ambient noise levels in the project vicinity above levels existing without the project?	<input type="checkbox"/>	<input type="checkbox"/>	<input checked="" type="checkbox"/>	<input type="checkbox"/>
e) For a project located within an airport land use plan or, where such a plan has not been adopted, within two miles of a public airport or public use airport, would the project expose people residing or working in the project area to excessive noise levels?	<input type="checkbox"/>	<input type="checkbox"/>	<input type="checkbox"/>	<input checked="" type="checkbox"/>
f) For a project within the vicinity of a private airstrip, would the project expose people residing or working in the project area to excessive noise levels?	<input type="checkbox"/>	<input type="checkbox"/>	<input type="checkbox"/>	<input checked="" type="checkbox"/>

SUMMARY OF IMPACTS IN PREVIOUS DOCUMENTS

- The ASR EIR/EA identified significant noise impacts due to exposure of sensitive receptors to elevated noise and vibration levels during construction activities and increased noise levels during operational phases. The following mitigation measures were identified to reduce impacts to a less than significant level:
 - *Mitigation Measure NZ-1a: Prohibit Ancillary and Unnecessary Equipment During Nighttime Well Drilling Activities*
 - *Mitigation Measure NZ-1b: Employ Noise-Reducing Construction practices to Meet Nighttime Standards*
 - *Mitigation Measure NZ-1c: Prepare a Noise Control Plan*
 - *Mitigation Measure NZ-1d: Disseminate Essential Information to Residences and Implement a Complaint/Response Tracking System*
 - *Mitigation Measure NZ-2 – Design Pump Stations to Meet Local Noise Standards*
- Addendum No. 1 to the ASR EIR/EA identified a potentially significant impact resulting from implementation of ASR Phase 2 due to the exposure of noise-sensitive land used to construction noise in excess of applicable standards. This impact would be reduced to less than significant with the implementation of the following mitigation measures:
 - *Mitigation Measure NZ-1a: Prohibit Ancillary and Unnecessary Equipment During Nighttime Well Drilling Activities*
 - *Mitigation Measure NZ-1b: Employ Noise-Reducing Construction Practices to Meet Nighttime Standards*
 - *Mitigation Measure NZ-1c: Prepare a Noise Control Plan*
 - *Mitigation Measure NZ-1d: Disseminate Essential Information to Residences and Implement a Complaint/Response Tracking System*
- Addendum No. 2 to the ASR EIR/EA identified potentially significant impacts to nearby residences to noise levels in excess of standards and a temporary increase in ambient noise levels during

EXHIBIT 16-A

Initial Study Checklist Backflush Basin Expansion

construction of the Hilby Pump Station. These impacts could be reduced to less than significant levels with the implementation of the following mitigation measures:

- *Mitigation Measure NZ-1a: Prohibit Ancillary and Unnecessary Equipment During Nighttime Well Drilling Activities*
- *Mitigation Measure NZ-1b: Employ Noise-Reducing Construction Practices to Meet Nighttime Standards*
- *Mitigation Measure NZ-1c: Prepare a Noise Control Plan*
- Addendum No. 3 to the ASR EIR/EA also identified potentially significant impacts to nearby residences to noise levels in excess of standards and a temporary increase in ambient noise levels during construction of the Monterey Pipeline Re-Alignment. These impacts could be reduced to less than significant levels with the implementation of Mitigation Measures NZ-1a, NZ-1b, and NZ-1c.

DISCUSSION

a, d) Less Than Significant Impact: Project construction would generate temporary increases in noise associated with the use of construction equipment. Project construction could result in the exposure of nearby sensitive receptors to increased noise levels beyond existing conditions. These impacts would, however, be temporary. In addition, adherence to standard construction noise measures would further reduce noise impacts, including reducing the severity of impacts on adjacent noise sensitive uses.

b) Less than Significant Impact: The proposed Backflush Basin Expansion would not generate any groundborne vibration.

c) No Impact: The components of the Proposed Project would not generate any noise during operation. The existing facilities at the Santa Margarita site currently generate minimal noise. The Proposed Project includes sound walls to lessen the disturbance to nearby sensitive receptors from the existing ASR wells. See **Figure 2** for more details.

e, f) No Impact: The proposed Backflush Basin Expansion are not located within two miles of a municipal airport or private airstrip and would not add new sensitive receptors to the site that would be exposed to existing or future nearby noise sources.

CONCLUSION

The proposed Backflush Basin Expansion would not result in any new significant impacts or cause an increase in severity of any significant impacts identified in the ASR EIR/EA related to noise.

13. Population and Housing

EXISTING SETTING

The proposed Backflush Basin Expansion site is located in the City of Seaside. The 2010 U.S. Census population of the City of Seaside was 33,025 persons, and the City's housing stock contains 10,872 occupied residential units, resulting in an average household size of 3.04 persons per household. The estimated population as of January 2014 was 33,534 persons. Based on Association of Monterey Bay Area Governments (AMBAG) projections, population is projected to increase in Seaside by approximately 3,095 people between 2010 and 2020. Based on the 2014 AMBAG Regional Housing Needs Allocation Plan, the total number of housing units which need to be planned in Seaside between 2014 and 2023 in order to

EXHIBIT 16-A

Initial Study Checklist
Backflush Basin Expansion

meet Seaside’s regional housing need allocation was 393 new units, including 95 very low income, 62 low income, 72 moderate income, and 164 above moderate-income households.

CHECKLIST

	Potentially Significant Impact	Less than Significant with Mitigation Incorporated	Less than Significant Impact	No Impact
Would the project:				
a) Induce substantial population growth in an area, either directly (for example, by proposing new homes and businesses) or indirectly (for example, through extension of roads or other infrastructure)?	<input type="checkbox"/>	<input type="checkbox"/>	<input type="checkbox"/>	<input checked="" type="checkbox"/>
b) Displace substantial numbers of existing housing, necessitating the construction of replacement housing elsewhere?	<input type="checkbox"/>	<input type="checkbox"/>	<input type="checkbox"/>	<input checked="" type="checkbox"/>
c) Displace substantial numbers of people, necessitating the construction of replacement housing elsewhere?	<input type="checkbox"/>	<input type="checkbox"/>	<input type="checkbox"/>	<input checked="" type="checkbox"/>

SUMMARY OF IMPACTS IN PREVIOUS DOCUMENTS

- No potential impacts to population and housing were identified in the ASR EIR/EA
- No potential impacts to population and housing were identified in Addendum No. 1 to the ASR EIR/EA resulting from implementation of ASR Phase 2.
- No potential impacts to population and housing were identified in Addendum No. 2 to the ASR EIR/EA resulting from the construction and operation of the Hilby Pump Station.
- No potential impacts to population and housing were identified in Addendum No. 3 to the ASR EIR/EA resulting from implementation of the Monterey Pipeline Re-Alignment.

DISCUSSION

a, b, and c) No Impact. The proposed Backflush Basin Expansion would not induce population growth or displace existing housing or people. The expansion of the backflush basin is to accommodate water generated by the maintenance of ASR wells that have been evaluated in previous environmental documents. Water generated by the ASR system serves to replace diversions from the Carmel River and is not created an additional source of water.

CONCLUSION

The proposed Backflush Basin Expansion would not result in any new significant impacts or cause an increase in severity of any significant impacts identified in the ASR EIR/EA related to population and housing.

EXHIBIT 16-A

Initial Study Checklist
Backflush Basin Expansion

14. Public Services

EXISTING SETTING

The proposed Backflush Basin Expansion would not impact public services; therefore, a discussion of the existing setting is not included.

CHECKLIST

	Potentially Significant Impact	Less than Significant with Mitigation Incorporated	Less than Significant Impact	No Impact
a) Would the project result in substantial adverse physical impacts associated with the provision of new or physically altered governmental facilities, need for new or physically altered governmental facilities, the construction of which could cause significant environmental impacts, in order to maintain acceptable service ratios, response times or other performance objectives for any of the public services:	<input type="checkbox"/>	<input type="checkbox"/>	<input type="checkbox"/>	<input checked="" type="checkbox"/>
Fire protection?	<input type="checkbox"/>	<input type="checkbox"/>	<input type="checkbox"/>	<input checked="" type="checkbox"/>
Police protection?	<input type="checkbox"/>	<input type="checkbox"/>	<input type="checkbox"/>	<input checked="" type="checkbox"/>
Schools?	<input type="checkbox"/>	<input type="checkbox"/>	<input type="checkbox"/>	<input checked="" type="checkbox"/>
Parks?	<input type="checkbox"/>	<input type="checkbox"/>	<input type="checkbox"/>	<input checked="" type="checkbox"/>
Other public facilities?	<input type="checkbox"/>	<input type="checkbox"/>	<input type="checkbox"/>	<input checked="" type="checkbox"/>

SUMMARY OF IMPACTS IN PREVIOUS DOCUMENTS

- No potential impacts to public services were identified in the ASR EIR/EA.
- No potential impacts to public services were identified in Addendum No. 1 to the ASR EIR/EA resulting from implementation of Phase 2.
- No potential impacts to public services were identified in Addendum No. 2 to the ASR EIR/EA resulting from construction or operation of the Hilby Pump Station.
- No potential impacts to public services were identified in Addendum No. 3 to the ASR EIR/EA resulting from implementation of the Monterey Pipeline Re-Alignment.

DISCUSSION

a) No Impact: Implementation of the proposed Backflush Basin Expansion would not result in new significant impacts resulting from new or altered governmental facilities, due to the fact that it is a component of a water infrastructure project, and therefore would not increase the use of schools and parks or increase the need for fire and police protection.

CONCLUSION

The proposed Backflush Basin Expansion would not result in any new significant impacts or cause an increase in severity of any significant impacts identified in the ASR EIR/EA related to public services.

EXHIBIT 16-A

Initial Study Checklist
Backflush Basin Expansion

15. Recreation

EXISTING SETTING

The proposed Backflush Basin Expansion would not impact recreational resources; therefore, a discussion of the existing setting is not included.

CHECKLIST

	Potentially Significant Impact	Less than Significant with Mitigation Incorporated	Less than Significant Impact	No Impact
a) Would the project increase the use of existing neighborhood and regional parks or other recreational facilities such that substantial physical deterioration of the facility would occur or be accelerated?	<input type="checkbox"/>	<input type="checkbox"/>	<input type="checkbox"/>	<input checked="" type="checkbox"/>
b) Does the project include recreational facilities or require the construction or expansion of recreational facilities which might have an adverse physical effect on the environment?	<input type="checkbox"/>	<input type="checkbox"/>	<input type="checkbox"/>	<input checked="" type="checkbox"/>

SUMMARY OF IMPACTS IN PREVIOUS DOCUMENTS

- No potential impacts to recreation facilities were identified in the ASR EIR/EA.
- No potential impacts to recreational facilities were identified in Addendum No. 1 to the ASR EIR/EA resulting from implementation of Phase 2.
- No potential impacts to recreational facilities were identified in Addendum No. 2 to the ASR EIR/EA resulting from construction or operation of the Hilby Pump Station.
- No potential impacts to recreational facilities were identified in Addendum No. 3 to the ASR EIR/EA resulting from implementation of the Monterey Pipeline Re-Alignment.

DISCUSSION

a, b) No Impact: The proposed Backflush Basin Expansion would not result in new significant impacts because there would be no direct or indirect increased use of parks or recreational facilities as part of the Proposed Project. No additional recreational facilities are included in the proposed Backflush Basin Expansion.

CONCLUSION

The proposed Backflush Basin Expansion would not result in any new significant impacts or cause an increase in severity of any significant impacts identified in the ASR EIR/EA related to recreation resources.

16. Transportation and Traffic

EXISTING SETTING

The proposed Backflush Basin Expansion site is located off General Jim Moore Boulevard, near the intersection of Eucalyptus Road and General Jim Moore Boulevard in the City of Seaside. The surrounding

EXHIBIT 16-A

Initial Study Checklist
Backflush Basin Expansion

area is open space and residential with normally light to medium traffic patterns, depending on the time of day. General Jim Moore Boulevard is a major street that is utilized by commuters in the Cities of Seaside, Del Rey Oaks, and Monterey. The closest highways that would potentially be used for materials transport and by construction workers in transit to the Proposed project site are Highway 1, Highway 218, and Highway 68.

CHECKLIST

Would the project:	Potentially Significant Impact	Less than Significant with Mitigation Incorporated	Less than Significant Impact	No Impact
a) Conflict with an applicable plan, ordinance or policy establishing measures of effectiveness for the performance of the circulation system, taking into account all modes of transportation including mass transit and non-motorized travel and relevant components of the circulation system, including but not limited to intersections, streets, highways and freeways, pedestrian and bicycle paths, and mass transit?	<input type="checkbox"/>	<input type="checkbox"/>	<input checked="" type="checkbox"/>	<input type="checkbox"/>
b) Conflict with an applicable congestion management program, including, but not limited to level of service standards and travel demand measures, or other standards established by the county congestion management agency for designated roads or highways?	<input type="checkbox"/>	<input type="checkbox"/>	<input checked="" type="checkbox"/>	<input type="checkbox"/>
c) Result in a change in air traffic patterns, including either an increase in traffic levels or a change in location that results in substantial safety risks?	<input type="checkbox"/>	<input type="checkbox"/>	<input type="checkbox"/>	<input checked="" type="checkbox"/>
d) Substantially increase hazards due to a design feature (e.g., sharp curves or dangerous intersections) or incompatible uses (e.g., farm equipment)?	<input type="checkbox"/>	<input type="checkbox"/>	<input type="checkbox"/>	<input checked="" type="checkbox"/>
e) Result in inadequate emergency access?	<input type="checkbox"/>	<input type="checkbox"/>	<input type="checkbox"/>	<input checked="" type="checkbox"/>
f) Conflict with adopted policies, plans, or programs regarding public transit, bicycle, or pedestrian facilities, or otherwise decrease the performance or safety of such facilities?	<input type="checkbox"/>	<input type="checkbox"/>	<input type="checkbox"/>	<input checked="" type="checkbox"/>

SUMMARY OF IMPACTS IN PREVIOUS DOCUMENTS

- The ASR EIR/EA found the ASR Project would have the following less than significant impacts to traffic and circulation:
 - temporary construction-related traffic increases,
 - construction phase conflicts with bus service lines and temporary pathway/bikeway closures,
 - increased traffic and level of service degradation from operational phases,
 - an increased demand for parking.

No mitigation measures were required.

- Addendum No. 1 to the ASR EIR/EA did not identify any significant impacts related to traffic and transportation related to implementation of ASR Phase 2.

EXHIBIT 16-A

Initial Study Checklist Backflush Basin Expansion

- Addendum No. 2 to the ASR EIR/EA did not identify any significant impacts related to traffic and transportation resulting from construction or operation of the Hilby Pump Station.
- Addendum No. 3 to the ASR EIR/EA identified potentially significant impacts related to conflicts with plans and congestion management programs. In addition, the re-alignment of the Monterey Pipeline could potentially result in inadequate emergency access during construction. These impacts could be reduced to less than significant levels with the implementation of *Mitigation Measure TR-2: Traffic Control and Safety Assurance Plan* from the Pure Water Monterey Mitigation Monitoring and Reporting Plan.

DISCUSSION

a, b) Less than Significant Impact: The proposed Backflush Basin Expansion would result in minimal temporary increases in traffic during construction. Construction worker traffic will result from the estimated four workers onsite during the day which could result in up to eight vehicle trips per day from workers (four AM trips and four PM trips). This would not be considered a substantial increase in peak hour trips due to the low volumes and the short duration of the construction period.

Operation and maintenance of the Backflush Basin Expansion would not require additional employee vehicle trips, as there are existing MPWMD facilities at the Santa Margarita site that require routine maintenance. This is considered a less than significant impact.

c, d, e, f, g) No Impact: Implementation of the proposed Backflush Basin Expansion would not impact air traffic operations because the nearest airports are over 2 miles away. The proposed Backflush Basin Expansion do not involve any construction within existing roadway travel lanes, bike lanes or near any transit stops, and would not increase hazards based on a design feature or result in emergency access concerns. The proposed second driveway on General Jim Moore Boulevard would provide an additional point of access to the Santa Margarita site for emergency vehicles. During construction, access to the proposed Backflush Basin Expansion site will be provided by an existing driveway off General Jim Moore Boulevard and construction workers will park onsite; therefore, there would be no significant parking or access impacts.

CONCLUSION

The proposed Backflush Basin Expansion would not result in any new significant impacts or cause an increase in severity of any significant impacts identified in the ASR EIR/EA related to transportation and traffic.

17. Utilities and Service Systems

EXISTING SETTING

The Monterey Regional Waste Management District manages the Monterey Peninsula's (including the proposed Backflush Basin Expansion site) solid waste collection, disposal, and recycling system. It also receives most of Monterey County's sewage sludge. The Waste Management District operates the Monterey Peninsula Landfill and a transfer station. Any solid waste generated by Proposed Project construction or operation would be disposed of at the landfill or diverted for recycling or reuse at the materials recovery facility.

EXHIBIT 16-A

Initial Study Checklist
Backflush Basin Expansion

CHECKLIST

Would the project:	Potentially Significant Impact	Less than Significant with Mitigation Incorporated	Less than Significant Impact	No Impact
a) Exceed wastewater treatment requirements of the applicable Regional Water Quality Control Board?	<input type="checkbox"/>	<input type="checkbox"/>	<input type="checkbox"/>	<input checked="" type="checkbox"/>
b) Require or result in the construction of new water or wastewater treatment facilities or expansion of existing facilities, the construction of which could cause significant environmental effects?	<input type="checkbox"/>	<input type="checkbox"/>	<input type="checkbox"/>	<input checked="" type="checkbox"/>
c) Require or result in the construction of new storm water drainage facilities or expansion of existing facilities, the construction of which could cause significant environmental effects?	<input type="checkbox"/>	<input type="checkbox"/>	<input type="checkbox"/>	<input checked="" type="checkbox"/>
d) Have sufficient water supplies available to serve the project from existing entitlements and resources, or are new or expanded entitlements needed?	<input type="checkbox"/>	<input type="checkbox"/>	<input type="checkbox"/>	<input checked="" type="checkbox"/>
e) Result in a determination by the wastewater treatment provider which serves or may serve the project that it has adequate capacity to serve the project's projected demand in addition to the provider's existing commitments?	<input type="checkbox"/>	<input type="checkbox"/>	<input type="checkbox"/>	<input checked="" type="checkbox"/>
f) Be served by a landfill with sufficient permitted capacity to accommodate the project's solid waste disposal needs?	<input type="checkbox"/>	<input type="checkbox"/>	<input checked="" type="checkbox"/>	<input type="checkbox"/>
g) Comply with federal, state, and local statutes and regulations related to solid waste?	<input type="checkbox"/>	<input type="checkbox"/>	<input checked="" type="checkbox"/>	<input type="checkbox"/>

SUMMARY OF IMPACTS IN PREVIOUS DOCUMENTS

- The ASR EIR/EA identified a potentially significant impact related to the temporary disruption of existing underground utilities during construction. This impact could be reduced to a less than significant level with the implementation of *Mitigation Measure PS-2: Coordinate Relocation and Interruptions of Service with Utility Providers during Construction* and *PS-3: Project All Existing Utilities Slated to Remain*. Addendum No. 1 to the ASR EIR/EA did not identify any significant impacts to utilities and service systems resulting from ASR Phase 2.
- Addendum No. 2 to the ASR EIR/EA did not identify any significant impacts to utilities and service systems resulting from the construction and operation of the Hilby Pump Station.
- Addendum No. 3 to the ASR EIR/EA identified a potentially significant impact resulting from solid waste disposal and compliance with regulations related to solid waste during construction of the Monterey Pipeline Re-alignment. These impacts could be reduced to a less than significant level with the implementation of *Mitigation Measure PS-3: Construction Waste Reduction and Recycling Plan* from the Pure Water Monterey Mitigation Monitoring and Reporting Plan.

DISCUSSION

a, b, c, e) No Impact: A component of the Proposed Project is to expand the backflush basin at the Santa Margarita site. This will enable MPWMD to dispose of a larger amount of backflush water produced by

EXHIBIT 16-A

Initial Study Checklist
Backflush Basin Expansion

regular maintained of the ASR well system. Water deposited into the backflush basin will either percolate into the Seaside Groundwater Basin or evaporate. The Proposed Project would not generate any additional water that has not already been accounted for in previous environmental documents. The Backflush Basin Expansion would not exceed wastewater treatment requirements of the Regional Water Quality Control Board. Although the backflush basin is intended to store and dispose of backflush water generated by maintenance of the ASR wells, it will also serve as a stormwater retention basin because it is the lowest point of the site. Stormwater captured in the basin will either percolate into the Seaside Groundwater Basin or evaporate. The proposed Backflush Basin Expansion would not result in any new significant impacts or increased severity of previously identified significant impacts from the ASR EIR/EA.

d) No Impact: The proposed Backflush Basin Expansion would not require additional water rights or entitlements. The Modifications would enable MPWMD to fully exercise their existing water rights to divert excess flows from the Carmel River for injection into the ASR wells during wet weather periods. MPWMD would be required to comply with all applicable permit conditions.

f, g) Less than Significant Impact: The proposed Backflush Basin Expansion would result in a less than significant impact in terms of solid waste generation consistent with the analysis in the ASR EIR/EA and its Addenda.

CONCLUSION

The proposed Backflush Basin Expansion would not result in any new significant impacts or cause an increase in severity of any significant impacts identified in the ASR EIR/EA related to utilities and service systems.

18. Mandatory Findings of Significance

CHECKLIST

	Potentially Significant Impact	Less than Significant with Mitigation Incorporated	Less than Significant Impact	No Impact
a) Does the project have the potential to degrade the quality of the environment, substantially reduce the habitat of a fish or wildlife species, cause a fish or wildlife population to drop below self-sustaining levels, threaten to eliminate a plant or animal community, reduce the number or restrict the range of a rare or endangered plant or animal or eliminate important examples of the major periods of California history or prehistory?	<input type="checkbox"/>	<input type="checkbox"/>	<input checked="" type="checkbox"/>	<input type="checkbox"/>
b) Does the project have impacts that are individually limited, but cumulatively considerable? (“Cumulatively considerable” means that the incremental effects of a project are considerable when viewed in connection with the effects of past projects, the effects of other current projects, and the effects of probable future projects)?	<input type="checkbox"/>	<input type="checkbox"/>	<input checked="" type="checkbox"/>	<input type="checkbox"/>
c) Does the project have environmental effects which will cause substantial adverse effects on human beings, either directly or indirectly?	<input type="checkbox"/>	<input type="checkbox"/>	<input checked="" type="checkbox"/>	<input type="checkbox"/>

EXHIBIT 16-A

Initial Study Checklist
Backflush Basin Expansion

SUMMARY OF IMPACTS IN PREVIOUS DOCUMENTS

- The ASR EIR/EA found that there would be less than significant cumulative impacts in all issue areas with the exception of NO_x and PM₁₀ emissions, noise and vibration generated during construction. Both of these cumulative significant impacts would be reduced to less than significant with the implementation of Mitigation Measure Cume-1: Coordinate with Relevant Local Agencies to Develop and Implement a Phased Construction Plan to Reduce Cumulative Traffic, Air Quality, and Noise Impacts.
- Addendum No. 1 to the ASR EIR/EA did not identify any cumulatively considerable impacts related to implementation of ASR Phase 2.
- Addendum No. 2 to the ASR EIR/EA did not identify any cumulatively considerable impacts related to construction and operation of the Hilby Pump Station.
- Addendum No. 3 to the ASR EIR/EA did not identify any cumulatively considerable impacts related to implementation of the Monterey Pipeline Re-Alignment.

DISCUSSION

a, b, c) Less than Significant Impact: The Backflush Basin Expansion would not substantially degrade or reduce wildlife species or habitat or impact historic resources, as identified in this analysis. Potential cumulative impacts associated with the Modifications would primarily occur in connection with temporary construction-related effects. As described above, a cumulative analysis for the ASR Project was performed in the ASR EIR/EA and its previous Addenda. Construction and operation of the Backflush Basin Expansion would not result in adverse impacts on human beings, either directly or indirectly; potential impacts would be temporary in nature and mitigated through the implementation of mitigation measures (to the extent they are applicable) previously identified in the ASR EIR/EA. The Backflush Basin Expansion would not result in any new significant impacts or cause an increase in severity of any significant impacts beyond those identified in the ASR EIR/EA and its Addenda.

EXHIBIT 16-A

Initial Study Checklist
Backflush Basin Expansion

IV. REPORT PREPARATION AND REFERENCES

California Department of Toxic Substances Control, 2016. EnviroStor Database <http://www.envirostor.dtsc.ca.gov/public/>, accessed online on May 6, 2016.

City of Seaside, 2003. Seaside General Plan.

City of Seaside, 2010. 2007 Zoning District Map.

Denise Duffy and Associates, 2012. Addendum No. 1 to the Phase 1 ASR Environmental Impact Report/Environmental Assessment.

Denise Duffy and Associates, 2016. Addendum No. 2 to the Phase 1 ASR Environmental Impact Report/Environmental Assessment.

Denise Duffy and Associates, 2017. Addendum No. 3 to the Phase 1 ASR Environmental Impact Report/Environmental Assessment.

Denise Duffy and Associates, 2015. Pure Water Monterey Groundwater Replenishment Project Final Environmental Impact Report.

Federal Emergency Management Agency, 2009. Flood Insurance Rate Map for Monterey County, California, Panel 0327G.

IFC Jones and Stokes, 2006. Phase 1 Aquifer Storage and Recovery Project Final Environmental Impact Report/Environmental Assessment.

IFC Jones and Stokes, 2010. Monterey County General Plan Final Environmental Impact Report.

Intergovernmental Panel on Climate Change, 2007. Climate Change 2007 Mitigation of Climate Change.

Jennings and Hayes, 1994. *Amphibian and Reptile Species of Special Concern in California*.

Monterey Bay Air Resources District, 2016. Guidelines for Implementing the California Environmental Quality Act. http://mbard.org/wp-content/uploads/2016/03/Attachment_Guidelines-for-Implementing-CEQA.pdf, accessed online on May 6, 2016.

Monterey Bay Air Resources District, 2017. *2012-2015 Air Quality Management Plan*.

Monterey County, 2010a. 2010 Monterey County General Plan, Figure AWCP4, Williamson Act Lands.

Monterey County, 2010b. 2010 Monterey County General Plan, Figure 8b, Federal Emergency Management Agency 100 Year Flood.

Monterey County, 2010c. 2010 Monterey County General Plan, Figure 8d, Dam Inundation.

Pueblo Water Resources, 2009. *Geotechnical Investigation for New Electrical & Chemical Feed Building, Seaside, California*.

Stebbins, 2003. *A Field Guide to Western Reptiles and Amphibians*. Third Edition.

Zeiner et al., 1998. *California's Wildlife, Volume I, Amphibians and Reptiles*.

EXHIBIT 16-A

Initial Study Checklist
Backflush Basin Expansion

Zeiner et al., 1990a. *California's Wildlife, Volume II, Birds.*

Zeiner et al., 1990b. *California's Wildlife, Volume III, Mammals.*

Backflush Basin Expansion

EXHIBIT 16-A

ATTACHMENT 2

AIR QUALITY AND GHG CALCULATION SPREADSHEETS

EXHIBIT 16-A

Backflush Basin Expansion

This page is intentionally blank.

ASR Addendum No. 4 - Backflush Basin Modifications - Monterey County, Annual

**ASR Addendum No. 4 - Backflush Basin Modifications
Monterey County, Annual**

1.0 Project Characteristics

1.1 Land Usage

Land Uses	Size	Metric	Lot Acreage	Floor Surface Area	Population
General Light Industry	82.70	1000sqft	1.90	82,700.00	0

1.2 Other Project Characteristics

Urbanization	Urban	Wind Speed (m/s)	3.6	Precipitation Freq (Days)	55
Climate Zone	4			Operational Year	2019
Utility Company	Pacific Gas & Electric Company				
CO2 Intensity (lb/MW hr)	641.35	CH4 Intensity (lb/MW hr)	0.029	N2O Intensity (lb/MW hr)	0.006

1.3 User Entered Comments & Non-Default Data

ASR Addendum No. 4 - Backflush Basin Modifications - Monterey County, Annual

Project Characteristics -

Land Use - Lot acreage provided is worse case scenario because it includes the entire Santa Margarita Site. Actual footprint of disturbance will be less.

Construction Phase - No demolition is proposed as part of the project. No new buildings are proposed as part of the project, no architectural coatings are required. This is primarily a grading project.

Grading - Total Acres Graded estimates provided are worst case scenarios, the entire Santa Margarita site is 1.9 acres. The actual area of disturbance will be less.

Demolition - No demolition is proposed as part of the project.

Trips and VMT - It is estimated that 4 workers will be needed for each of the project construction phases.

Architectural Coating - No architectural coatings are required.

Solid Waste - No soil waste will be generated during project operation.

Land Use Change - Vegetation type at project site is maritime chaparral and existing water infrastructure facilities. Grassland present used because it is most similar to maritime chaparral. All vegetation cleared during grading will be replaced using hydroseeding.

Sequestration - No trees will be removed.

EXHIBIT 16-A

ASR Addendum No. 4 - Backflush Basin Modifications - Monterey County, Annual

Table Name	Column Name	Default Value	New Value
tblConstructionPhase	NumDays	4.00	50.00
tblConstructionPhase	NumDays	2.00	6.00
tblConstructionPhase	PhaseEndDate	9/5/2018	10/17/2018
tblConstructionPhase	PhaseEndDate	6/26/2019	10/31/2019
tblConstructionPhase	PhaseEndDate	8/30/2018	8/8/2018
tblConstructionPhase	PhaseStartDate	8/31/2018	8/9/2018
tblConstructionPhase	PhaseStartDate	6/13/2019	10/18/2019
tblConstructionPhase	PhaseStartDate	8/29/2018	8/1/2018
tblGrading	AcresOfGrading	18.75	1.90
tblGrading	AcresOfGrading	3.00	1.90
tblSolidWaste	SolidWasteGenerationRate	102.55	0.00
tblTripsAndVMT	HaulingTripNumber	0.00	5.00
tblTripsAndVMT	WorkerTripNumber	13.00	4.00

2.0 Emissions Summary

EXHIBIT 16-A

ASR Addendum No. 4 - Backflush Basin Modifications - Monterey County, Annual

Quarter	Start Date	End Date	Maximum Unmitigated ROG + NOX (tons/quarter)	Maximum Mitigated ROG + NOX (tons/quarter)
1	8-1-2018	10-31-2018	0.5317	0.5317
		Highest	0.5317	0.5317

2.2 Overall Operational

Unmitigated Operational

	ROG	NOx	CO	SO2	Fugitive PM10	Exhaust PM10	PM10 Total	Fugitive PM2.5	Exhaust PM2.5	PM2.5 Total	Bio- CO2	NBio- CO2	Total CO2	CH4	N2O	CO2e
Category	tons/yr										MT/yr					
Area	0.3806	1.0000e-005	1.0700e-003	0.0000		0.0000	0.0000		0.0000	0.0000	0.0000	2.0500e-003	2.0500e-003	1.0000e-005	0.0000	2.1900e-003
Energy	0.0118	0.1069	0.0898	6.4000e-004		8.1300e-003	8.1300e-003		8.1300e-003	8.1300e-003	0.0000	315.1421	315.1421	0.0112	3.9900e-003	316.6126
Mobile	0.2277	0.9920	2.7700	6.5900e-003	0.4769	8.9400e-003	0.4859	0.1282	8.4300e-003	0.1366	0.0000	602.4056	602.4056	0.0350	0.0000	603.2813
Waste						0.0000	0.0000		0.0000	0.0000	0.0000	0.0000	0.0000	0.0000	0.0000	0.0000
Water						0.0000	0.0000		0.0000	0.0000	6.0673	30.1041	36.1714	0.6245	0.0150	56.2534
Total	0.6200	1.0990	2.8609	7.2300e-003	0.4769	0.0171	0.4940	0.1282	0.0166	0.1447	6.0673	947.6538	953.7211	0.6708	0.0190	976.1495

ASR Addendum No. 4 - Backflush Basin Modifications - Monterey County, Annual

2.3 Vegetation

Vegetation

	CO2e
Category	MT
Vegetation Land Change	0.0000
Total	0.0000

3.0 Construction Detail

Construction Phase

Phase Number	Phase Name	Phase Type	Start Date	End Date	Num Days Week	Num Days	Phase Description
1	Site Preparation	Site Preparation	8/1/2018	8/8/2018	5	6	
2	Grading	Grading	8/9/2018	10/17/2018	5	50	
3	Paving	Paving	10/18/2019	10/31/2019	5	10	

Acres of Grading (Site Preparation Phase): 1.9

Acres of Grading (Grading Phase): 1.9

Acres of Paving: 0

Residential Indoor: 0; Residential Outdoor: 0; Non-Residential Indoor: 0; Non-Residential Outdoor: 0; Striped Parking Area: 0 (Architectural Coating – sqft)

OffRoad Equipment

EXHIBIT 16-A

ASR Addendum No. 4 - Backflush Basin Modifications - Monterey County, Annual

Phase Name	Offroad Equipment Type	Amount	Usage Hours	Horse Power	Load Factor
Paving	Cement and Mortar Mixers	1	6.00	9	0.56
Site Preparation	Graders	1	8.00	187	0.41
Paving	Pavers	1	6.00	130	0.42
Paving	Rollers	1	7.00	80	0.38
Grading	Rubber Tired Dozers	1	6.00	247	0.40
Grading	Tractors/Loaders/Backhoes	1	7.00	97	0.37
Paving	Tractors/Loaders/Backhoes	1	8.00	97	0.37
Site Preparation	Tractors/Loaders/Backhoes	1	8.00	97	0.37
Grading	Graders	1	6.00	187	0.41
Paving	Paving Equipment	1	8.00	132	0.36
Site Preparation	Rubber Tired Dozers	1	7.00	247	0.40

Trips and VMT

Phase Name	Offroad Equipment Count	Worker Trip Number	Vendor Trip Number	Hauling Trip Number	Worker Trip Length	Vendor Trip Length	Hauling Trip Length	Worker Vehicle Class	Vendor Vehicle Class	Hauling Vehicle Class
Site Preparation	3	8.00	0.00	5.00	10.80	7.30	20.00	LD_Mix	HDT_Mix	HHDT
Grading	3	8.00	0.00	0.00	10.80	7.30	20.00	LD_Mix	HDT_Mix	HHDT
Paving	5	4.00	0.00	0.00	10.80	7.30	20.00	LD_Mix	HDT_Mix	HHDT

3.1 Mitigation Measures Construction

EXHIBIT 16-A

ASR Addendum No. 4 - Backflush Basin Modifications - Monterey County, Annual

3.2 Site Preparation - 2018

Unmitigated Construction On-Site

	ROG	NOx	CO	SO2	Fugitive PM10	Exhaust PM10	PM10 Total	Fugitive PM2.5	Exhaust PM2.5	PM2.5 Total	Bio- CO2	NBio- CO2	Total CO2	CH4	N2O	CO2e
Category	tons/yr										MT/yr					
Fugitive Dust					0.0168	0.0000	0.0168	8.8000e-003	0.0000	8.8000e-003	0.0000	0.0000	0.0000	0.0000	0.0000	0.0000
Off-Road	5.4200e-003	0.0622	0.0242	5.0000e-005		2.8600e-003	2.8600e-003		2.6300e-003	2.6300e-003	0.0000	4.7229	4.7229	1.4700e-003	0.0000	4.7596
Total	5.4200e-003	0.0622	0.0242	5.0000e-005	0.0168	2.8600e-003	0.0197	8.8000e-003	2.6300e-003	0.0114	0.0000	4.7229	4.7229	1.4700e-003	0.0000	4.7596

Unmitigated Construction Off-Site

	ROG	NOx	CO	SO2	Fugitive PM10	Exhaust PM10	PM10 Total	Fugitive PM2.5	Exhaust PM2.5	PM2.5 Total	Bio- CO2	NBio- CO2	Total CO2	CH4	N2O	CO2e
Category	tons/yr										MT/yr					
Hauling	3.0000e-005	8.7000e-004	1.8000e-004	0.0000	4.0000e-005	1.0000e-005	5.0000e-005	1.0000e-005	1.0000e-005	2.0000e-005	0.0000	0.1984	0.1984	1.0000e-005	0.0000	0.1986
Vendor	0.0000	0.0000	0.0000	0.0000	0.0000	0.0000	0.0000	0.0000	0.0000	0.0000	0.0000	0.0000	0.0000	0.0000	0.0000	0.0000
Worker	1.3000e-004	1.3000e-004	1.1200e-003	0.0000	1.9000e-004	0.0000	1.9000e-004	5.0000e-005	0.0000	5.0000e-005	0.0000	0.1925	0.1925	1.0000e-005	0.0000	0.1928
Total	1.6000e-004	1.0000e-003	1.3000e-003	0.0000	2.3000e-004	1.0000e-005	2.4000e-004	6.0000e-005	1.0000e-005	7.0000e-005	0.0000	0.3909	0.3909	2.0000e-005	0.0000	0.3913

EXHIBIT 16-A

ASR Addendum No. 4 - Backflush Basin Modifications - Monterey County, Annual

3.2 Site Preparation - 2018

Mitigated Construction On-Site

	ROG	NOx	CO	SO2	Fugitive PM10	Exhaust PM10	PM10 Total	Fugitive PM2.5	Exhaust PM2.5	PM2.5 Total	Bio- CO2	NBio- CO2	Total CO2	CH4	N2O	CO2e
Category	tons/yr										MT/yr					
Fugitive Dust					0.0168	0.0000	0.0168	8.8000e-003	0.0000	8.8000e-003	0.0000	0.0000	0.0000	0.0000	0.0000	0.0000
Off-Road	5.4200e-003	0.0622	0.0242	5.0000e-005		2.8600e-003	2.8600e-003		2.6300e-003	2.6300e-003	0.0000	4.7229	4.7229	1.4700e-003	0.0000	4.7596
Total	5.4200e-003	0.0622	0.0242	5.0000e-005	0.0168	2.8600e-003	0.0197	8.8000e-003	2.6300e-003	0.0114	0.0000	4.7229	4.7229	1.4700e-003	0.0000	4.7596

Mitigated Construction Off-Site

	ROG	NOx	CO	SO2	Fugitive PM10	Exhaust PM10	PM10 Total	Fugitive PM2.5	Exhaust PM2.5	PM2.5 Total	Bio- CO2	NBio- CO2	Total CO2	CH4	N2O	CO2e
Category	tons/yr										MT/yr					
Hauling	3.0000e-005	8.7000e-004	1.8000e-004	0.0000	4.0000e-005	1.0000e-005	5.0000e-005	1.0000e-005	1.0000e-005	2.0000e-005	0.0000	0.1984	0.1984	1.0000e-005	0.0000	0.1986
Vendor	0.0000	0.0000	0.0000	0.0000	0.0000	0.0000	0.0000	0.0000	0.0000	0.0000	0.0000	0.0000	0.0000	0.0000	0.0000	0.0000
Worker	1.3000e-004	1.3000e-004	1.1200e-003	0.0000	1.9000e-004	0.0000	1.9000e-004	5.0000e-005	0.0000	5.0000e-005	0.0000	0.1925	0.1925	1.0000e-005	0.0000	0.1928
Total	1.6000e-004	1.0000e-003	1.3000e-003	0.0000	2.3000e-004	1.0000e-005	2.4000e-004	6.0000e-005	1.0000e-005	7.0000e-005	0.0000	0.3909	0.3909	2.0000e-005	0.0000	0.3913

EXHIBIT 16-A

ASR Addendum No. 4 - Backflush Basin Modifications - Monterey County, Annual

3.3 Grading - 2018

Unmitigated Construction On-Site

	ROG	NOx	CO	SO2	Fugitive PM10	Exhaust PM10	PM10 Total	Fugitive PM2.5	Exhaust PM2.5	PM2.5 Total	Bio- CO2	NBio- CO2	Total CO2	CH4	N2O	CO2e
Category	tons/yr										MT/yr					
Fugitive Dust					0.1139	0.0000	0.1139	0.0622	0.0000	0.0622	0.0000	0.0000	0.0000	0.0000	0.0000	0.0000
Off-Road	0.0374	0.4267	0.1691	3.5000e-004		0.0199	0.0199		0.0183	0.0183	0.0000	32.2337	32.2337	0.0100	0.0000	32.4845
Total	0.0374	0.4267	0.1691	3.5000e-004	0.1139	0.0199	0.1338	0.0622	0.0183	0.0805	0.0000	32.2337	32.2337	0.0100	0.0000	32.4845

Unmitigated Construction Off-Site

	ROG	NOx	CO	SO2	Fugitive PM10	Exhaust PM10	PM10 Total	Fugitive PM2.5	Exhaust PM2.5	PM2.5 Total	Bio- CO2	NBio- CO2	Total CO2	CH4	N2O	CO2e
Category	tons/yr										MT/yr					
Hauling	0.0000	0.0000	0.0000	0.0000	0.0000	0.0000	0.0000	0.0000	0.0000	0.0000	0.0000	0.0000	0.0000	0.0000	0.0000	0.0000
Vendor	0.0000	0.0000	0.0000	0.0000	0.0000	0.0000	0.0000	0.0000	0.0000	0.0000	0.0000	0.0000	0.0000	0.0000	0.0000	0.0000
Worker	1.0800e-003	1.0500e-003	9.3200e-003	2.0000e-005	1.5900e-003	2.0000e-005	1.6000e-003	4.2000e-004	1.0000e-005	4.4000e-004	0.0000	1.6043	1.6043	9.0000e-005	0.0000	1.6065
Total	1.0800e-003	1.0500e-003	9.3200e-003	2.0000e-005	1.5900e-003	2.0000e-005	1.6000e-003	4.2000e-004	1.0000e-005	4.4000e-004	0.0000	1.6043	1.6043	9.0000e-005	0.0000	1.6065

EXHIBIT 16-A

ASR Addendum No. 4 - Backflush Basin Modifications - Monterey County, Annual

3.3 Grading - 2018

Mitigated Construction On-Site

	ROG	NOx	CO	SO2	Fugitive PM10	Exhaust PM10	PM10 Total	Fugitive PM2.5	Exhaust PM2.5	PM2.5 Total	Bio- CO2	NBio- CO2	Total CO2	CH4	N2O	CO2e
Category	tons/yr										MT/yr					
Fugitive Dust					0.1139	0.0000	0.1139	0.0622	0.0000	0.0622	0.0000	0.0000	0.0000	0.0000	0.0000	0.0000
Off-Road	0.0374	0.4267	0.1691	3.5000e-004		0.0199	0.0199		0.0183	0.0183	0.0000	32.2336	32.2336	0.0100	0.0000	32.4845
Total	0.0374	0.4267	0.1691	3.5000e-004	0.1139	0.0199	0.1338	0.0622	0.0183	0.0805	0.0000	32.2336	32.2336	0.0100	0.0000	32.4845

Mitigated Construction Off-Site

	ROG	NOx	CO	SO2	Fugitive PM10	Exhaust PM10	PM10 Total	Fugitive PM2.5	Exhaust PM2.5	PM2.5 Total	Bio- CO2	NBio- CO2	Total CO2	CH4	N2O	CO2e
Category	tons/yr										MT/yr					
Hauling	0.0000	0.0000	0.0000	0.0000	0.0000	0.0000	0.0000	0.0000	0.0000	0.0000	0.0000	0.0000	0.0000	0.0000	0.0000	0.0000
Vendor	0.0000	0.0000	0.0000	0.0000	0.0000	0.0000	0.0000	0.0000	0.0000	0.0000	0.0000	0.0000	0.0000	0.0000	0.0000	0.0000
Worker	1.0800e-003	1.0500e-003	9.3200e-003	2.0000e-005	1.5900e-003	2.0000e-005	1.6000e-003	4.2000e-004	1.0000e-005	4.4000e-004	0.0000	1.6043	1.6043	9.0000e-005	0.0000	1.6065
Total	1.0800e-003	1.0500e-003	9.3200e-003	2.0000e-005	1.5900e-003	2.0000e-005	1.6000e-003	4.2000e-004	1.0000e-005	4.4000e-004	0.0000	1.6043	1.6043	9.0000e-005	0.0000	1.6065

EXHIBIT 16-A

ASR Addendum No. 4 - Backflush Basin Modifications - Monterey County, Annual

3.4 Paving - 2019

Unmitigated Construction On-Site

	ROG	NOx	CO	SO2	Fugitive PM10	Exhaust PM10	PM10 Total	Fugitive PM2.5	Exhaust PM2.5	PM2.5 Total	Bio- CO2	NBio- CO2	Total CO2	CH4	N2O	CO2e
Category	tons/yr										MT/yr					
Off-Road	4.5200e-003	0.0459	0.0445	7.0000e-005		2.6100e-003	2.6100e-003		2.4100e-003	2.4100e-003	0.0000	6.0105	6.0105	1.8700e-003	0.0000	6.0572
Paving	0.0000					0.0000	0.0000		0.0000	0.0000	0.0000	0.0000	0.0000	0.0000	0.0000	0.0000
Total	4.5200e-003	0.0459	0.0445	7.0000e-005		2.6100e-003	2.6100e-003		2.4100e-003	2.4100e-003	0.0000	6.0105	6.0105	1.8700e-003	0.0000	6.0572

Unmitigated Construction Off-Site

	ROG	NOx	CO	SO2	Fugitive PM10	Exhaust PM10	PM10 Total	Fugitive PM2.5	Exhaust PM2.5	PM2.5 Total	Bio- CO2	NBio- CO2	Total CO2	CH4	N2O	CO2e
Category	tons/yr										MT/yr					
Hauling	0.0000	0.0000	0.0000	0.0000	0.0000	0.0000	0.0000	0.0000	0.0000	0.0000	0.0000	0.0000	0.0000	0.0000	0.0000	0.0000
Vendor	0.0000	0.0000	0.0000	0.0000	0.0000	0.0000	0.0000	0.0000	0.0000	0.0000	0.0000	0.0000	0.0000	0.0000	0.0000	0.0000
Worker	1.0000e-004	9.0000e-005	8.2000e-004	0.0000	1.6000e-004	0.0000	1.6000e-004	4.0000e-005	0.0000	4.0000e-005	0.0000	0.1559	0.1559	1.0000e-005	0.0000	0.1561
Total	1.0000e-004	9.0000e-005	8.2000e-004	0.0000	1.6000e-004	0.0000	1.6000e-004	4.0000e-005	0.0000	4.0000e-005	0.0000	0.1559	0.1559	1.0000e-005	0.0000	0.1561

EXHIBIT 16-A

ASR Addendum No. 4 - Backflush Basin Modifications - Monterey County, Annual

3.4 Paving - 2019

Mitigated Construction On-Site

	ROG	NOx	CO	SO2	Fugitive PM10	Exhaust PM10	PM10 Total	Fugitive PM2.5	Exhaust PM2.5	PM2.5 Total	Bio- CO2	NBio- CO2	Total CO2	CH4	N2O	CO2e
Category	tons/yr										MT/yr					
Off-Road	4.5200e-003	0.0459	0.0445	7.0000e-005		2.6100e-003	2.6100e-003		2.4100e-003	2.4100e-003	0.0000	6.0105	6.0105	1.8700e-003	0.0000	6.0572
Paving	0.0000					0.0000	0.0000		0.0000	0.0000	0.0000	0.0000	0.0000	0.0000	0.0000	0.0000
Total	4.5200e-003	0.0459	0.0445	7.0000e-005		2.6100e-003	2.6100e-003		2.4100e-003	2.4100e-003	0.0000	6.0105	6.0105	1.8700e-003	0.0000	6.0572

Mitigated Construction Off-Site

	ROG	NOx	CO	SO2	Fugitive PM10	Exhaust PM10	PM10 Total	Fugitive PM2.5	Exhaust PM2.5	PM2.5 Total	Bio- CO2	NBio- CO2	Total CO2	CH4	N2O	CO2e
Category	tons/yr										MT/yr					
Hauling	0.0000	0.0000	0.0000	0.0000	0.0000	0.0000	0.0000	0.0000	0.0000	0.0000	0.0000	0.0000	0.0000	0.0000	0.0000	0.0000
Vendor	0.0000	0.0000	0.0000	0.0000	0.0000	0.0000	0.0000	0.0000	0.0000	0.0000	0.0000	0.0000	0.0000	0.0000	0.0000	0.0000
Worker	1.0000e-004	9.0000e-005	8.2000e-004	0.0000	1.6000e-004	0.0000	1.6000e-004	4.0000e-005	0.0000	4.0000e-005	0.0000	0.1559	0.1559	1.0000e-005	0.0000	0.1561
Total	1.0000e-004	9.0000e-005	8.2000e-004	0.0000	1.6000e-004	0.0000	1.6000e-004	4.0000e-005	0.0000	4.0000e-005	0.0000	0.1559	0.1559	1.0000e-005	0.0000	0.1561

4.0 Operational Detail - Mobile

EXHIBIT 16-A

ASR Addendum No. 4 - Backflush Basin Modifications - Monterey County, Annual

4.1 Mitigation Measures Mobile

	ROG	NOx	CO	SO2	Fugitive PM10	Exhaust PM10	PM10 Total	Fugitive PM2.5	Exhaust PM2.5	PM2.5 Total	Bio- CO2	NBio- CO2	Total CO2	CH4	N2O	CO2e
Category	tons/yr										MT/yr					
Mitigated	0.2277	0.9920	2.7700	6.5900e-003	0.4769	8.9400e-003	0.4859	0.1282	8.4300e-003	0.1366	0.0000	602.4056	602.4056	0.0350	0.0000	603.2813
Unmitigated	0.2277	0.9920	2.7700	6.5900e-003	0.4769	8.9400e-003	0.4859	0.1282	8.4300e-003	0.1366	0.0000	602.4056	602.4056	0.0350	0.0000	603.2813

4.2 Trip Summary Information

Land Use	Average Daily Trip Rate			Unmitigated	Mitigated
	Weekday	Saturday	Sunday	Annual VMT	Annual VMT
General Light Industry	576.42	109.16	56.24	1,271,028	1,271,028
Total	576.42	109.16	56.24	1,271,028	1,271,028

4.3 Trip Type Information

Land Use	Miles			Trip %			Trip Purpose %		
	H-W or C-W	H-S or C-C	H-O or C-NW	H-W or C-W	H-S or C-C	H-O or C-NW	Primary	Diverted	Pass-by
General Light Industry	9.50	7.30	7.30	59.00	28.00	13.00	92	5	3

4.4 Fleet Mix

Land Use	LDA	LDT1	LDT2	MDV	LHD1	LHD2	MHD	HHD	OBUS	UBUS	MCY	SBUS	MH
General Light Industry	0.526395	0.032321	0.201107	0.146365	0.026644	0.006320	0.017996	0.025422	0.004154	0.003072	0.007973	0.001269	0.000961

EXHIBIT 16-A

ASR Addendum No. 4 - Backflush Basin Modifications - Monterey County, Annual

5.0 Energy Detail

Historical Energy Use: N

5.1 Mitigation Measures Energy

	ROG	NOx	CO	SO2	Fugitive PM10	Exhaust PM10	PM10 Total	Fugitive PM2.5	Exhaust PM2.5	PM2.5 Total	Bio- CO2	NBio- CO2	Total CO2	CH4	N2O	CO2e
Category	tons/yr										MT/yr					
Electricity Mitigated						0.0000	0.0000		0.0000	0.0000	0.0000	198.7222	198.7222	8.9900e-003	1.8600e-003	199.5009
Electricity Unmitigated						0.0000	0.0000		0.0000	0.0000	0.0000	198.7222	198.7222	8.9900e-003	1.8600e-003	199.5009
NaturalGas Mitigated	0.0118	0.1069	0.0898	6.4000e-004		8.1300e-003	8.1300e-003		8.1300e-003	8.1300e-003	0.0000	116.4199	116.4199	2.2300e-003	2.1300e-003	117.1117
NaturalGas Unmitigated	0.0118	0.1069	0.0898	6.4000e-004		8.1300e-003	8.1300e-003		8.1300e-003	8.1300e-003	0.0000	116.4199	116.4199	2.2300e-003	2.1300e-003	117.1117

EXHIBIT 16-A

ASR Addendum No. 4 - Backflush Basin Modifications - Monterey County, Annual

5.2 Energy by Land Use - NaturalGas

Unmitigated

	NaturalGas Use	ROG	NOx	CO	SO2	Fugitive PM10	Exhaust PM10	PM10 Total	Fugitive PM2.5	Exhaust PM2.5	PM2.5 Total	Bio- CO2	NBio- CO2	Total CO2	CH4	N2O	CO2e
Land Use	kBTU/yr	tons/yr										MT/yr					
General Light Industry	2.18163e+006	0.0118	0.1069	0.0898	6.4000e-004		8.1300e-003	8.1300e-003		8.1300e-003	8.1300e-003	0.0000	116.4199	116.4199	2.2300e-003	2.1300e-003	117.1117
Total		0.0118	0.1069	0.0898	6.4000e-004		8.1300e-003	8.1300e-003		8.1300e-003	8.1300e-003	0.0000	116.4199	116.4199	2.2300e-003	2.1300e-003	117.1117

Mitigated

	NaturalGas Use	ROG	NOx	CO	SO2	Fugitive PM10	Exhaust PM10	PM10 Total	Fugitive PM2.5	Exhaust PM2.5	PM2.5 Total	Bio- CO2	NBio- CO2	Total CO2	CH4	N2O	CO2e
Land Use	kBTU/yr	tons/yr										MT/yr					
General Light Industry	2.18163e+006	0.0118	0.1069	0.0898	6.4000e-004		8.1300e-003	8.1300e-003		8.1300e-003	8.1300e-003	0.0000	116.4199	116.4199	2.2300e-003	2.1300e-003	117.1117
Total		0.0118	0.1069	0.0898	6.4000e-004		8.1300e-003	8.1300e-003		8.1300e-003	8.1300e-003	0.0000	116.4199	116.4199	2.2300e-003	2.1300e-003	117.1117

ASR Addendum No. 4 - Backflush Basin Modifications - Monterey County, Annual

5.3 Energy by Land Use - Electricity

Unmitigated

	Electricity Use	Total CO2	CH4	N2O	CO2e
Land Use	kWh/yr	MT/yr			
General Light Industry	683102	198.7222	8.9900e-003	1.8600e-003	199.5009
Total		198.7222	8.9900e-003	1.8600e-003	199.5009

Mitigated

	Electricity Use	Total CO2	CH4	N2O	CO2e
Land Use	kWh/yr	MT/yr			
General Light Industry	683102	198.7222	8.9900e-003	1.8600e-003	199.5009
Total		198.7222	8.9900e-003	1.8600e-003	199.5009

6.0 Area Detail

6.1 Mitigation Measures Area

EXHIBIT 16-A

ASR Addendum No. 4 - Backflush Basin Modifications - Monterey County, Annual

	ROG	NOx	CO	SO2	Fugitive PM10	Exhaust PM10	PM10 Total	Fugitive PM2.5	Exhaust PM2.5	PM2.5 Total	Bio- CO2	NBio- CO2	Total CO2	CH4	N2O	CO2e
Category	tons/yr										MT/yr					
Mitigated	0.3806	1.0000e-005	1.0700e-003	0.0000		0.0000	0.0000		0.0000	0.0000	0.0000	2.0500e-003	2.0500e-003	1.0000e-005	0.0000	2.1900e-003
Unmitigated	0.3806	1.0000e-005	1.0700e-003	0.0000		0.0000	0.0000		0.0000	0.0000	0.0000	2.0500e-003	2.0500e-003	1.0000e-005	0.0000	2.1900e-003

6.2 Area by SubCategory

Unmitigated

	ROG	NOx	CO	SO2	Fugitive PM10	Exhaust PM10	PM10 Total	Fugitive PM2.5	Exhaust PM2.5	PM2.5 Total	Bio- CO2	NBio- CO2	Total CO2	CH4	N2O	CO2e
SubCategory	tons/yr										MT/yr					
Architectural Coating	0.0575					0.0000	0.0000		0.0000	0.0000	0.0000	0.0000	0.0000	0.0000	0.0000	0.0000
Consumer Products	0.3230					0.0000	0.0000		0.0000	0.0000	0.0000	0.0000	0.0000	0.0000	0.0000	0.0000
Landscaping	1.0000e-004	1.0000e-005	1.0700e-003	0.0000		0.0000	0.0000		0.0000	0.0000	0.0000	2.0500e-003	2.0500e-003	1.0000e-005	0.0000	2.1900e-003
Total	0.3806	1.0000e-005	1.0700e-003	0.0000		0.0000	0.0000		0.0000	0.0000	0.0000	2.0500e-003	2.0500e-003	1.0000e-005	0.0000	2.1900e-003

EXHIBIT 16-A

ASR Addendum No. 4 - Backflush Basin Modifications - Monterey County, Annual

6.2 Area by SubCategory

Mitigated

	ROG	NOx	CO	SO2	Fugitive PM10	Exhaust PM10	PM10 Total	Fugitive PM2.5	Exhaust PM2.5	PM2.5 Total	Bio- CO2	NBio- CO2	Total CO2	CH4	N2O	CO2e
SubCategory	tons/yr										MT/yr					
Architectural Coating	0.0575					0.0000	0.0000		0.0000	0.0000	0.0000	0.0000	0.0000	0.0000	0.0000	0.0000
Consumer Products	0.3230					0.0000	0.0000		0.0000	0.0000	0.0000	0.0000	0.0000	0.0000	0.0000	0.0000
Landscaping	1.0000e-004	1.0000e-005	1.0700e-003	0.0000		0.0000	0.0000		0.0000	0.0000	0.0000	2.0500e-003	2.0500e-003	1.0000e-005	0.0000	2.1900e-003
Total	0.3806	1.0000e-005	1.0700e-003	0.0000		0.0000	0.0000		0.0000	0.0000	0.0000	2.0500e-003	2.0500e-003	1.0000e-005	0.0000	2.1900e-003

7.0 Water Detail

7.1 Mitigation Measures Water

EXHIBIT 16-A

ASR Addendum No. 4 - Backflush Basin Modifications - Monterey County, Annual

	Total CO2	CH4	N2O	CO2e
Category	MT/yr			
Mitigated	36.1714	0.6245	0.0150	56.2534
Unmitigated	36.1714	0.6245	0.0150	56.2534

7.2 Water by Land Use

Unmitigated

	Indoor/Outdoor Use	Total CO2	CH4	N2O	CO2e
Land Use	Mgal	MT/yr			
General Light Industry	19.1244 / 0	36.1714	0.6245	0.0150	56.2534
Total		36.1714	0.6245	0.0150	56.2534

ASR Addendum No. 4 - Backflush Basin Modifications - Monterey County, Annual

7.2 Water by Land Use

Mitigated

	Indoor/Outdoor Use	Total CO2	CH4	N2O	CO2e
Land Use	Mgal	MT/yr			
General Light Industry	19.1244 / 0	36.1714	0.6245	0.0150	56.2534
Total		36.1714	0.6245	0.0150	56.2534

8.0 Waste Detail

8.1 Mitigation Measures Waste

Category/Year

	Total CO2	CH4	N2O	CO2e
	MT/yr			
Mitigated	0.0000	0.0000	0.0000	0.0000
Unmitigated	0.0000	0.0000	0.0000	0.0000

ASR Addendum No. 4 - Backflush Basin Modifications - Monterey County, Annual

8.2 Waste by Land Use

Unmitigated

	Waste Disposed	Total CO2	CH4	N2O	CO2e
Land Use	tons	MT/yr			
General Light Industry	0	0.0000	0.0000	0.0000	0.0000
Total		0.0000	0.0000	0.0000	0.0000

Mitigated

	Waste Disposed	Total CO2	CH4	N2O	CO2e
Land Use	tons	MT/yr			
General Light Industry	0	0.0000	0.0000	0.0000	0.0000
Total		0.0000	0.0000	0.0000	0.0000

9.0 Operational Offroad

Equipment Type	Number	Hours/Day	Days/Year	Horse Power	Load Factor	Fuel Type
----------------	--------	-----------	-----------	-------------	-------------	-----------

EXHIBIT 16-A

ASR Addendum No. 4 - Backflush Basin Modifications - Monterey County, Annual

10.0 Stationary Equipment

Fire Pumps and Emergency Generators

Equipment Type	Number	Hours/Day	Hours/Year	Horse Power	Load Factor	Fuel Type
----------------	--------	-----------	------------	-------------	-------------	-----------

Boilers

Equipment Type	Number	Heat Input/Day	Heat Input/Year	Boiler Rating	Fuel Type
----------------	--------	----------------	-----------------	---------------	-----------

User Defined Equipment

Equipment Type	Number
----------------	--------

11.0 Vegetation

EXHIBIT 16-A

ASR Addendum No. 4 - Backflush Basin Modifications - Monterey County, Annual

	Total CO2	CH4	N2O	CO2e
Category	MT			
Unmitigated	0.0000	0.0000	0.0000	0.0000

11.1 Vegetation Land Change

Vegetation Type

	Initial/Final	Total CO2	CH4	N2O	CO2e
	Acres	MT			
Grassland	1.9 / 1.9	0.0000	0.0000	0.0000	0.0000
Total		0.0000	0.0000	0.0000	0.0000

EXHIBIT 16-A

Backflush Basin Expansion

ATTACHMENT 3

GEOTECHNICAL INVESTIGATION AS AMENDED BY UPDATE LETTER

EXHIBIT 16-A

Backflush Basin Expansion

This page is intentionally blank.

EXHIBIT 16-A

GEOTECHNICAL INVESTIGATION
FOR
NEW ELECTRICAL & CHEMICAL
FEED BUILDING
SEASIDE, CALIFORNIA

FOR
PUEBLO WATER RESOURCES
VENTURA, CALIFORNIA

BY
PACIFIC CREST ENGINEERING INC.
CONSULTING GEOTECHNICAL ENGINEERS
0922-M242-E12
APRIL 2009
www.4pacific-crest.com

EXHIBIT 16-A

Pueblo Water Resources
April 30, 2009

Project No. 0922-M242-E12

TABLE OF CONTENTS

	<u>Page No.</u>
LETTER OF TRANSMITTAL	
GEOTECHNICAL INVESTIGATION	
Purpose and Scope	1
Location and Description	1
Field Investigation	2
Laboratory Investigation	2
Soil Conditions	3
Regional Seismic Setting	4
Seismic Hazards	4
DISCUSSIONS, CONCLUSIONS AND RECOMMENDATIONS	
General	7
Primary Geotechnical Considerations	7
Site Preparation	8
Cut and Fill Slopes	10
Erosion Control	11
Foundations – Spread Footings	11
Slab-On-Grade Construction	13
Utility Trenches	14
Lateral Pressures	15
Surface Drainage	16
Pavement Design	17
Soil Corrosivity	18
Plan Review	19
LIMITATIONS AND UNIFORMITY OF CONDITIONS	
IMPORTANT INFORMATION ABOUT...	
APPENDIX A	
Regional Site Map	24
Site Map Showing Test Borings	25
Boring Log Explanation	26
Log of Test Borings	27
Caltrans Corrosivity Test Summary	30
Keyway Detail	31
Surcharge Pressure Diagram	32
Typical Retaining Wall Drain Detail	33

444 Airport Blvd, Suite 106
Watsonville, CA 95076
Phone: 831-722-9446
Fax: 831-722-9158

April 30, 2009

Project No. 0922-M242-E12

Pueblo Water Resources
4478 Market Street, Suite 705
Ventura, CA 93003

Attention: Mr. Steve Tanner, PE

Subject: Geotechnical Investigation
New Electrical & Chemical Feed Building
Santa Margarita Aquifer Storage and Recovery Project
1110 General Jim Moore Boulevard
Seaside, California

Dear Mr. Tanner,

In accordance with your authorization, we have performed a geotechnical investigation for the above referenced project located at 1110 General Jim Moore Boulevard, in Seaside, California.

The accompanying report presents our conclusions and recommendations as well as the results of the geotechnical investigation on which they are based. If you have any questions concerning the data, conclusions or recommendations presented in this report, please call our office.

Very truly yours,

PACIFIC CREST ENGINEERING INC.



Cara L. Russo
Staff Geologist



Michael D. Klempes
President/Principal Geotechnical Engineer
G.E. 2204
Exp. 3/31/10

Copies: 4 to Client

GEOTECHNICAL INVESTIGATION

PURPOSE AND SCOPE

This report describes the geotechnical investigation and presents results, including recommendations, for your new electrical and chemical feed building project located at 1110 General Jim Moore Boulevard in Seaside, California. Our scope of services for this project has consisted of:

1. Discussions with you and the members of the design team including Mr. Joe Oliver of the Monterey Peninsula Water District.
2. Review of the pertinent published material concerning the site including County planning maps, preliminary site plans, geologic and topographic maps, and other available literature.
3. The drilling and logging of 2 test borings.
4. Laboratory analysis of retrieved soil samples.
5. Engineering analysis of the field and laboratory results.
6. Preparation of this report documenting our investigation and presenting recommendations for the design of the project.

LOCATION AND DESCRIPTION

The project site is located at 1110 General Jim Moore Boulevard on the east side of the road. Please refer to Figure No. 1, Regional Site Map, for the general vicinity of the project site. The project site is just south of the intersection with Eucalyptus Road and is located at the following coordinates:

Latitude = 36.620227 degrees
Longitude = -121.816631 degrees

At the time of our site visits, the vicinity of the proposed new electrical and chemical feed building was vacant. The plot was graded, stepped cut, and sloped to the west. A few native plants were scattered about, but the Older Dune Deposits were visible at the ground surface. The site of the proposed project was completely surrounded by a gravel loop. An existing trailer, wood shed on a concrete pad, a metal shed, and wells were present within the same parcel as the proposed new building.

EXHIBIT 16-A

Pueblo Water Resources
April 30, 2009

Page 2
Project No. 0922-M242-E12

It is our understanding that the project involves the construction of a one-story utility building with a total floor area of approximately 1,200 square feet. The existing building pad consists of a graded and stepped cut pad. The pad at the higher elevation will be excavated an additional 12 to 18 inches from its present location in order to bring the pad to one elevation. The southwestern portion of the building will have a 4 to 5 foot deep basement in the lower section of the building for double containment of fluids and spill control in the storage room. It is our understanding that the basement will be a concrete structure with a concrete slab-on-grade floor.

FIELD INVESTIGATION

Soil Borings

Two 6 inch diameter test borings were drilled on the site on April 17, 2009. The location of the test borings are shown on Figure No. 2, Site Map Showing Test Borings. The drilling method used was hydraulically operated continuous flight augers. A geologist from Pacific Crest Engineering Inc., was present during the drilling operations to log the soil encountered and to choose soil sampling type and locations.

Relatively undisturbed soil samples were obtained at various depths by driving a split spoon sampler 18 inches into the ground. This was achieved by dropping a 140 pound down hole safety hammer through a vertical height of 30 inches. The number of blows needed to drive the sampler for each 6 inch portion is recorded and the total number of blows needed to drive the last 12 inches is reported as the Standard Penetration Test (SPT) value. The outside diameter of the samplers used in this investigation was 3 inches and is noted respectively as "L" on the boring logs. All standard penetration test data has been normalized to a 2 inch O.D. sampler so as to be the SPT "N" value.

The soils encountered in the borings were continuously logged in the field and visually described in accordance with the Unified Soil Classification System (ASTM D2488 (Modified), Figure No. 3). The soil classification was verified and or modified upon completion of laboratory testing.

Appendix A contains the site plan showing the locations of the test borings and the Log of Test Borings presenting the soil profile explored in each boring, the sample locations, and the SPT "N" values for each sample. Stratification lines on the boring logs are approximate as the actual transition between soil types may be gradual.

LABORATORY INVESTIGATION

The laboratory testing program was developed to help in evaluating the engineering properties of the materials encountered on the site. Laboratory tests performed include:

EXHIBIT 16-A

- a. Moisture Density relationships in accordance with ASTM test D2937.
- b. Gradation tests in accordance with ASTM test D1140.
- c. Corrosivity testing including pH, resistivity, chloride concentration, and sulfate concentration.

The results of the laboratory tests are presented on the boring logs opposite the sample tested or within Appendix A.

SOIL CONDITIONS

Regional Geologic Maps

The surficial geology in the area of the project site is mapped as Older Coastal Dunes (Clark, Dupre', and Rosenberg, 1997). The Older Coastal Dunes are described as weakly consolidated, poorly graded fine to medium grained sand deposits. Some of these deposits are covered with a thin lens of eolian deposits. The native soils encountered in the test borings are consistent with this description.

Soil Borings

Our borings encountered a variety of soil including silty sand, sand with silt, and sand. Both test borings were drilled within the footprint of the proposed new electrical and chemical feed building. The following describes the soil conditions encountered within each test boring.

Boring No. 1 encountered brown silty sand in the upper 24 feet. The sand was fine to medium grained, sub-angular to sub-rounded shaped, and poorly graded. Mica flakes were scattered throughout the obtained samples and the samples tended to coarsen with depth. Trace rounded chert pebbles were noted near 6 ½ feet. The surface soils within the cut were fairly well compacted as the density near 3 ½ feet was described as hard. Overall, the density ranged from medium dense to hard. From 24 feet to the maximum explored depth of 36 feet the soil was described as yellowish tan sand. The sand was fine to medium grained with trace coarse grains, sub-angular to sub-rounded shaped, and poorly graded. Mica flakes were scattered throughout the collected samples. The density ranged from medium dense to very dense.

Boring No. 2 encountered dark brown sand with silt in the upper 5 feet. The sand was very fine to medium grained, sub-angular to sub-rounded shaped, and poorly graded. Mica flakes and trace rounded chert pebbles were scattered throughout the obtained sample. Trace granitic gravel was noted near 3 ½ feet. At this depth the density was described as medium dense. From 5 feet to the maximum depth explored of 16 ½ feet the boring encountered dark reddish brown sand with silt. The sand was fine to medium grained with trace coarse grains, sub-angular to sub-rounded shaped, and poorly graded. Mica flakes were scattered

throughout the collected samples. Trace rounded chert pebbles were noted from 11 to 11 ½ feet. At these depths the density was described as medium dense.

Groundwater was not encountered in any of the test borings to a maximum explored depth of 36 feet.

REGIONAL SEISMIC SETTING

The seismic setting of the site is one in which it is reasonable to assume that the site will experience significant seismic shaking during the lifetime of the project.

Based upon our review of the fault maps for the for the Monterey area (Clark, Dupre', and Rosenberg, 1997), and the Maps of Known Active Fault Near-Source Zones in California and Adjacent Portions of Nevada (CDMG, 1998), active or potentially active faults which may significantly affect the site include those listed in the Table No. 1, below.

TABLE No. 1, Faults in the Monterey Bay Area

Fault Name	Distance (miles)	Distance (km.)	Direction	Slip Rate* (mm/yr.)	M _w Max*
San Andreas – 1906 Segment	21.7	35.0	Northeast	24	7.9
Palo Colorado – Sur	12.0	19.3	Southwest	3	7.0
Rinconada	5.0	8.1	Northeast	1	7.5
Monterey Bay – Tularcitos	3.6	5.8	Southwest	0.5	7.3

*Source: CDMG, February, 1998

SEISMIC HAZARDS

A detailed investigation of seismic hazards is beyond our scope of services for this project. In general however, seismic hazards which may affect project sites in the Monterey Bay area include ground shaking, ground surface fault rupture, liquefaction and lateral spreading, and seismically induced slope instabilities. Geotechnical aspects of these issues are discussed below:

Ground Shaking

Ground shaking will be felt on the site. Structures founded on thick soft soil deposits are more likely to experience more destructive shaking, with higher amplitude and lower frequency, than structures founded on bedrock. Generally, shaking will be more intense closer to earthquake epicenters. Thick soft soil deposits large distances from earthquake

EXHIBIT 16-A

Pueblo Water Resources
April 30, 2009

Page 5
Project No. 0922-M242-E12

epicenters, however, may result in seismic accelerations significantly greater than expected in bedrock. Structures built in accordance with the latest edition of the California Building Code have an increased potential for experiencing relatively minor damage which should be repairable. The seismic design of the project should be based on the 2007 California Building Code (CBC) as it has incorporated the most recent seismic design parameters. The following values for the seismic design of the project site were derived or taken from the 2007 CBC:

TABLE No. 2, The 2007 CBC Seismic Design Parameters

Design Parameter	Specific to Site	Reference (See Note 1)
Site Class	D, Stiff Soil	Table 1613.5.2
Mapped Spectral Acceleration for Short Periods	$S_s = 1.302 \text{ g}$	Fig. 22-3, ASCE 7-05
Mapped Spectral Acceleration for 1-second Period	$S_1 = 0.558 \text{ g}$	Fig. 22-4, ASCE 7-05
Short Period Site Coefficient	$F_a = 1.0$	Table 1613.5.3(1)
1-Second Period Site Coefficient	$F_v = 1.5$	Table 1613.5.3(2)
MCE Spectral Response Acceleration for Short Period	$S_{MS} = 1.302 \text{ g}$	Section 1613.5.3
MCE Spectral Response Acceleration for 1-Second Period	$S_{M1} = 0.837 \text{ g}$	Section 1613.5.3
5% Damped Spectral Response Acceleration for Short Period	$S_{DS} = 0.868 \text{ g}$	Section 1613.5.4
5% Damped Spectral Response Acceleration for 1-Second Period	$S_{D1} = 0.558 \text{ g}$	Section 1613.5.4
Seismic Design Category (See Note 2)	D	Section 1613.5.6

Note 1: Design values may also have been obtained by using the Ground Motion Parameter Calculator available on the USGS website at <http://earthquake.usgs.gov/research/hazmaps/design/index.php>. Refer to the "Liquefaction" section for further information on how the Site Class may have been derived.

Note 2: Seismic Design Category assumes Class II occupancy per 2007 CBC Table 1604.5. Pacific Crest Engineering Inc. should be contacted for revised Table 2 seismic design parameters if the building has a different occupancy rating from the one assumed.

Ground Surface Fault Rupture

Ground surface fault rupture occurs along the surficial trace(s) of active faults during significant seismic events. Pacific Crest Engineering Inc. has not performed a specific investigation for the presence of active faults on the project site. Since the nearest known active or potentially active fault is mapped approximately 3.6 miles (approximately 5.8 km) from the site (Clark, Dupre', Rosenberg, 1997, and CDMG, 1998), the potential for ground surface fault rupture at this site is low.

Liquefaction

Liquefaction tends to occur in loose, saturated fine grained sands, coarse silts or clays with a low plasticity. Based upon our review of the regional liquefaction maps (Dupre' and Tinsley, 1980; Rosenberg, 2001) the site is located in an area classified as having a low potential for liquefaction. We did encounter loose, cohesionless clean sands within our test borings, however, we did not encounter groundwater in the upper 36 feet. Neither did we encounter clays with a Plasticity Index of 7 or lower (refer to the paper "Liquefaction Susceptibility Criteria for Silts and Clays" by Boulanger and Idriss, 2006). The soils encountered in are test borings were generally silty or poorly graded sands that were loose to medium dense near the surface and became very dense with depth.

EXHIBIT 16-A

Pueblo Water Resources
April 30, 2009

Page 6
Project No. 0922-M242-E12

Generally, we would not expect a significant amount of liquefaction to occur at this site, given the lack of groundwater in the upper 36 feet and the increasing density of the soils with depth. Our site specific investigation of this project site, including the nature of the subsurface soil, the location of the ground water table, and the estimated ground accelerations, leads to the conclusion that the liquefaction potential is low.

Liquefaction Induced Lateral Spreading

Liquefaction induced lateral spreading occurs when a liquefied soil mass fails toward an open slope face, or fails on an inclined topographic slope. Our analysis of the project site indicates that the potential for liquefaction to occur is low, and consequently the potential for lateral spreading is also low.

Landsliding

Seismically induced landsliding is a hazard with low potential for affecting your site since the site is relatively flat.

DISCUSSIONS, CONCLUSIONS AND RECOMMENDATIONS

GENERAL

1. The results of our investigation indicate that from a geotechnical engineering standpoint the property may be developed as proposed provided these recommendations are included in the design and construction.
2. Our laboratory testing indicates that the near surface soils possess low expansive properties. This analysis was based on several sieve analyses and our visual classification of the soils by a Staff Geologist based on the Unified Soil Classification System.
3. Grading and foundation plans should be reviewed by Pacific Crest Engineering Inc. during their preparation and prior to contract bidding.
4. Pacific Crest Engineering Inc. should be notified at least four (4) working days prior to any site clearing and grading operations on the property in order to observe the stripping and disposal of unsuitable materials, and to coordinate this work with the grading contractor. During this period, a pre-construction conference should be held on the site, with at least you or your representative, the grading contractor, a City or County representative and one of our engineers present. At this meeting, the project specifications and the testing and inspection responsibilities will be outlined and discussed.
5. Field observation and testing must be provided by a representative of Pacific Crest Engineering Inc., to enable them to form an opinion as to the degree of conformance of the exposed site conditions to those foreseen in this report, the adequacy of the site preparation, the acceptability of fill materials, and the extent to which the earthwork construction and the degree of compaction comply with the specification requirements. **Any work related to grading or foundation excavation that is performed without the full knowledge and direct observation of Pacific Crest Engineering Inc., the Geotechnical Engineer of Record, will render the recommendations of this report invalid, unless the Client hires a new Geotechnical Engineer who agrees to take over complete responsibility for this report's findings, conclusions and recommendations.** The new Geotechnical Engineer must agree to prepare a Transfer of Responsibility letter. This may require additional test borings and laboratory analysis if the new Geotechnical Engineer does not completely agree with our prior findings, conclusions and recommendations.

PRIMARY GEOTECHNICAL CONSIDERATIONS

6. The project site is located within a seismically active area and strong seismic shaking is expected to occur within the design lifetime of the project. Improvements should be designed and constructed in accordance with the most current CBC and the recommendations

of this report to minimize reaction to seismic shaking. Structures built in accordance with the latest edition of the California Building Code have an increased potential for experiencing relatively minor damage, which should be repairable, however strong seismic shaking could result in architectural damage and the need for post-earthquake repairs.

SITE PREPARATION

7. The initial preparation of the site will consist of the removal of any existing on-site debris. Septic tanks and leaching lines, if found, must be completely removed. The extent of this soil removal will be designated by a representative of Pacific Crest Engineering Inc. in the field. This material must be removed from the site.
8. Any voids created by removal of tree and root balls, septic tanks, and leach lines must be backfilled with properly compacted native soils that are free of organic and other deleterious materials or with approved imported fill.
9. Any wells encountered shall be capped in accordance with the requirements and approval of the County Health Department. The strength of the cap shall be equal to the adjacent soil and shall not be located within 5 feet of a structural footing.
10. Surface vegetation, tree roots and organically contaminated topsoil should then be removed ("stripped") from the area to be graded. In addition, any remaining debris or large rocks must also be removed (this includes asphalt or rocks greater than 2 inches in greatest dimension). This material may be stockpiled for future landscaping.
11. It is anticipated that the depth of stripping may be 2 to 4 inches, however the required depth of stripping must be based upon visual observations of a representative of Pacific Crest Engineering Inc., in the field. The depth of stripping will vary upon the type and density of vegetation across the project site and with the time of year. Areas with dense vegetation or groves of trees may require an increased depth of stripping.
12. It is possible that there are areas of man-made fill on the project site that our field investigation did not detect. Areas of man-made fill, if encountered on the project site will need to be completely excavated to undisturbed native material. The excavation process should be observed and the extent designated by a representative of Pacific Crest Engineering Inc., in the field. Any voids created by fill removal must be backfilled with properly compacted approved native soils that are free of organic and other deleterious materials, or with approved imported fill.
13. Following the stripping and backfilling of voids, the area should be excavated to the design soil subgrade elevation. The exposed soils in the building and paving areas should be scarified to a minimum depth of 8 inches, moisture conditioned, and compacted as an engineered fill except for any contaminated material noted by a representative of Pacific Crest Engineering Inc. in the field. The moisture conditioning procedure will depend on the

EXHIBIT 16-A

Pueblo Water Resources
April 30, 2009

Page 9
Project No. 0922-M242-E12

time of year that the work is done, but should result in the soils being 1 to 3 percent over their optimum moisture content at the time of compaction. Compaction of the exposed subgrade soils should extend 5 feet horizontally beyond all slabs, footings and pavement areas.

Note: If this work is done during or soon after the rainy season, the on-site soils and other materials may be too wet in their existing condition to be used as engineered fill. These materials may require a diligent and active drying and/or mixing operation to reduce the moisture content to the levels required to obtain adequate compaction as an engineered fill. If the on-site soils or other materials are too dry, water may need to be added. In some cases the time and effort to dry the on-site soil may be considered excessive, and the import of aggregate base may be required.

14. The soil on the project site should be compacted as follows:

- a. In pavement areas the upper 8 inches of subgrade, and all aggregate subbase and aggregate base, should be compacted to a minimum of 95% of its maximum dry density,
- b. In pavement areas all utility trench backfill should be compacted to 95% of its maximum dry density,
- c. All remaining soil on the project site should be compacted to a minimum of 90% of its maximum dry density.

15. The maximum dry density will be obtained from a laboratory compaction curve run in accordance with ASTM Procedure #D1557. This test will also establish the optimum moisture content of the material. Field density testing will be performed in accordance with ASTM Test #D2922 (nuclear method).

16. Native or imported soil used as engineered fill on this project should meet the following requirements:

- a. free of organics, debris, and other deleterious materials,
- b. free of "recycled" materials such as asphaltic concrete, concrete, brick, etc.,
- c. granular in nature, well graded, and contain sufficient binder to allow utility trenches to stand open,
- d. free of rocks in excess of 2 inches in size.

In addition to the above requirements, import fill should have a Plasticity Index between 4 and 12, and a minimum Resistance "R" Value of 30, and be non-expansive.

17. All native and import fill should be placed in maximum 8 inch lifts, before compaction, at a water content which is within 1 to 3 percent of the laboratory optimum value.

18. We recommend field density testing be performed in maximum 2 foot elevation differences. In general terms, we would recommend at least one compaction test per 200 linear feet of utility trench or retaining wall backfill, and at least one compaction test per

2,000 square feet of building or structure area. This is a subjective value and may be changed by the Geotechnical Engineer based on a review of the final project layout and exposed field conditions.

19. Samples of any proposed imported fill planned for use on this project should be submitted to Pacific Crest Engineering Inc. for appropriate testing and approval not less than ten (10) working days before the anticipated jobsite delivery. Imported fill material delivered to the project site without prior submittal of samples for appropriate testing and approval must be removed from the project site.

CUT AND FILL SLOPES

20. All fill slopes should be constructed with engineered fill meeting the minimum density requirements of this report and have a gradient no steeper than 3:1 (horizontal to vertical). Fill slopes should not exceed 15 feet in vertical height unless specifically reviewed by Pacific Crest Engineering Inc. Where the vertical height exceeds 15 feet, intermediate benches must be provided. These benches should be at least 6 feet wide and sloped to control surface drainage. A lined ditch should be used on the bench.

21. Fill slopes should be keyed into the native slopes by providing a 10 foot wide base keyway sloped negatively at least 2% into the bank. The depth of the keyways will vary, depending on the materials encountered. It is anticipated that the depth of the keyways may be 3 to 6 feet, but at all locations shall be at least 2 feet into firm material.

22. Subsequent keys may be required as the fill section progress upslope. Keys will be designated in the field by a representative of Pacific Crest Engineering Inc. See Figure No. 8 for general details.

23. Cut slopes shall not exceed a 3:1 (horizontal to vertical) gradient and a 15 foot vertical height unless specifically reviewed by a representative of Pacific Crest Engineering Inc. Where the vertical height exceeds 15 feet, intermediate benches must be provided. These benches should be at least 6 feet wide and sloped to control surface drainage. A lined ditch should be used on the bench.

24. The above slope gradients are based on the strength characteristics of the materials under conditions of normal moisture content that would result from rainfall falling directly on the slope, and do not take into account the additional activating forces applied by seepage from spring areas. Therefore, in order to maintain stable slopes at the recommended gradients, it is important that any seepage forces and accompanying hydrostatic pressure encountered be relieved by adequate drainage. Drainage facilities may include subdrains, gravel blankets, rock fill surface trenches or horizontally drilled drains. Configurations and type of drainage will be determined by a representative of Pacific Crest Engineering Inc. during the grading operations.

25. The surfaces of all cut and fill slopes should be prepared and maintained to reduce erosion. This work, at a minimum, should include track rolling of the slope and effective planting. The protection of the slopes should be installed as soon as practicable so that a sufficient growth will be established prior to inclement weather conditions. It is vital that no slope be left standing through a winter season without the erosion control measures having been provided.
26. The above recommended gradients do not preclude periodic maintenance of the slopes, as minor sloughing and erosion may take place.
27. If a fill slope is to be placed above a cut slope, the toe of the fill slope should be set back at least 8 feet horizontally from the top of the cut slope. A lateral surface drain should be placed in the area between the cut and fill slopes.

EROSION CONTROL

28. The surface soils are classified as having a high potential for erosion. Therefore, the finished ground surface should be planted with ground cover and continually maintained to minimize surface erosion. For specific and detailed recommendations regarding erosion control on and surrounding the project site, you should consult your civil engineer or an erosion control specialist.

FOUNDATIONS - SPREAD FOOTINGS

29. At the time we prepared this report, the grading plans had not been completed and the structure location and foundation details had not been finalized. We request an opportunity to review these items during the design stages to determine if supplemental recommendations will be required.
30. Considering the soil characteristics and site preparation recommendations, it is our opinion that an appropriate foundation system to support the proposed structures will consist of reinforced concrete spread footings bedded into firm native soil. This system could consist of continuous exterior footings, in conjunction with interior isolated spread footings or additional continuous footings or concrete slabs.
31. Footing widths and depths should be based upon the allowable bearing value but not less than the minimum widths and depths as shown in the table below. The footing excavations must be free of loose material prior to placing concrete. The footing excavations should be thoroughly saturated prior to placing concrete.

TABLE No. 3, Minimum Footing Widths and Depths

Number of Stories	Footing Width	Footing Depth
1	12 inches	12 inches
2	15 inches	18 inches
3	18 inches	24 inches
Multi-story	24 inches	24 inches

Please note: The minimum footing embedment is measured from the lowest existing and adjacent soil grade and should not include any concrete slab-on-grade, capillary break and sand cushion in the total depth of embedment.

32. Footings constructed to the given criteria may be designed for the following allowable bearing capacities:

- a. 2,000 psf for Dead plus Live Load
- b. a 1/3rd increase for Seismic or Wind Load

Please note: In computing the pressures transmitted to the soil by the footings, the embedded weight of the footing may be neglected.

33. Expected total settlement due to applied dead and live loads is not expected to exceed 1 inch across the length of the structure, with differential settlement of about 0.5 to 0.6 inches.

34. No footing should be placed closer than 8 feet to the top of a fill slope nor 6 feet from the base of a cut slope.

35. No footing shall be placed on slopes steeper than 4:1 (h:v). If the intent is to place the foundation on sloping ground which exceeds 4:1 (h:v), Pacific Crest Engineering Inc. should be contacted for an alternative pier and grade beam foundation design.

36. All footings should be excavated into firm native soil. No footings shall be constructed with the intent of placing engineered fill against the footing after the footing is poured, and counting that engineered fill as part of the embedment depth of the footing.

37. Footings may be assumed to have a resistance to lateral sliding of 0.35.

38. Footings may be assumed to have a lateral bearing pressure resistance value of 250 psf/ft.

39. All grade beams, thickened slab edges and other foundation elements which impart structure loads to the soil (from dead, live, wind or seismic loads) should be considered "footings" and constructed according to the recommendations of this section, including required depths below lowest adjacent soil grade.

40. Footing excavations must be observed by a representative of Pacific Crest Engineering Inc. before placement of formwork, steel and concrete to ensure bedding into proper material.

41. The footings should contain steel reinforcement as determined by the Project Civil or Structural Engineer in accordance with applicable CBC or ACI Standards.

SLAB-ON-GRADE CONSTRUCTION

42. Concrete slab-on-grade floors may be used for ground level construction on native soil or engineered fill. The upper 8 inches of slab subgrade should be processed and compacted to a minimum of 95% relative dry density.

43. Slabs may be structurally integrated with the footings. If the slabs are constructed as "free floating" slabs, they should be provided with a minimum ¼ inch felt separation between the slab and footing. The slabs should be separated into approximately 15' x 15' square sections with dummy joints or similar type crack control devices.

44. All concrete slabs-on-grade should be underlain by a minimum 4 inch thick capillary break of ¾ inch clean crushed rock (no fines). It is recommended that neither Class II baserock nor sand be employed as the capillary break material.

45. Where floor coverings are anticipated or vapor transmission may be a problem, a vapor/waterproof membrane should be placed between the capillary break layer and the floor slab in order to reduce the potential for moisture condensation under floor coverings. We recommend a high quality vapor retarder at least 10 mil thick and puncture resistant (Stego Wrap or equivalent). The vapor barrier must be a least 10 mil in thickness and meet the specifications for ASTM E 1745, Standard Specification For Water Vapor Retarder A 2-inch layer of moist sand on top of the membrane will help protect the membrane and will assist in equalizing the curing rate of the concrete.

Please Note: Recommendations given above for the reduction of moisture transmission through the slab are general in nature and present good construction practice. Moisture protection measures for concrete slabs-on-grade should meet applicable ACI and ASTM standards. Pacific Crest Engineering Inc. are not waterproofing experts. For a more complete and specific discussion of moisture protection within the structure, a waterproofing expert should be consulted.

46. Requirements for pre-wetting of the subgrade soils prior to the pouring of the slabs will depend on the specific soils and seasonal moisture conditions and will be determined by a representative of Pacific Crest Engineering Inc. at the time of construction. It is important that the subgrade soils be properly moisture conditioned at the time the concrete is poured. Subgrade moisture contents should not be allowed to exceed our moisture recommendations for effective compaction, and should be maintained until the slab is poured.

47. Slab thickness, reinforcement, and doweling should be determined by the Project Civil or Structural Engineer. The use of welded wire mesh is not recommended for slab reinforcement.

UTILITY TRENCHES

48. Utility trenches that are parallel to the sides of the building should be placed so that they do not extend below a line sloping down and away at a 2:1 (horizontal to vertical) slope from the bottom outside edge of all footings.

49. Utility pipes should be designed and constructed so that the top of pipe is a minimum of 24 inches below the finish subgrade elevation of any road or pavement areas. Any pipes within the top 24 inches of finish subgrade should be concrete encased, per design by the Project Civil Engineer.

50. For the purpose of this section of the report, backfill is defined as material placed in a trench starting one foot above the pipe, and bedding is all material placed in a trench below the backfill.

51. Unless concrete bedding is required around utility pipes, free-draining clean sand should be used as bedding. Sand bedding should be compacted to at least 95 percent relative compaction.

52. Approved imported clean sand or native soil should be used as utility trench backfill. Backfill in trenches located under and adjacent to structural fill, foundations, concrete slabs and pavements should be placed in horizontal layers no more than 8 inches thick. This includes areas such as sidewalks, patios, and other hardscape areas. Each layer of trench backfill should be water conditioned and compacted to at least 95 percent relative compaction. Clean sand is defined as 100 percent passing the #4 sieve, and less than 5 percent passing the #200 sieve.

53. All utility trenches beneath perimeter footing or grade beams should be backfilled with controlled density fill (such as 2-sack sand\cement slurry) to help minimize potential moisture intrusion below interior floors. The width of the plug should be at least three times the width of the footing or grade beam at the building perimeter, but not less than 36 inches. A representative from Pacific Crest Engineering Inc. should be contacted to observe the placement of slurry plugs. In addition, all utility pipes which penetrate through the footings, stemwalls or grade beams (below the exterior soil grade) should also be sealed water-tight, as determined by the Project Engineer or Architect.

54. A representative from our firm should be present to observe the bottom of all trench excavations, prior to placement of utility pipes and conduits. In addition, we should observe

EXHIBIT 16-A

the condition of the trench prior to placement of sand bedding, and to observe compaction of the sand bedding, in addition to any backfill planned above the bedding zone.

55. Jetting of the trench backfill is not recommended as it may result in an unsatisfactory degree of compaction.

56. Trenches must be shored as required by the local agency and the State of California Division of Industrial Safety construction safety orders.

LATERAL PRESSURES

57. Retaining walls with full drainage should be designed using the following criteria:

- a. The following lateral earth pressure values should be used for design:

TABLE No. 4, Active and At-Rest Earth Pressure Values

Backfill Slope (H:V)	Active Earth Pressure (psf/ft of depth)	At-rest Earth Pressure (psf/ft of depth)
Level	30	40
3:1	35	45
2:1	45	55

58. Active earth pressure values may be used when walls are free to yield an amount sufficient to develop the active earth pressure condition (about 1/2% of height). The effect of wall rotation should be considered for areas behind the planned retaining wall (pavements, foundations, slabs, etc.). **When walls are restrained at the top or to design for minimal wall rotation, use the at-rest earth pressure values.**

- a. For resisting passive earth pressure use 250 psf/ft of depth.
- b. A “coefficient of friction” between base of foundation and soil of 0.35.
- c. Exterior or interior wall footings may be designed for an allowable bearing capacity of 2,000 psf for Dead plus Live Load, with a 1/3rd increase for short term loads.
- d. To develop the resisting passive earth pressure, the retaining wall footings should be embedded a minimum of 18 inches below the lowest adjacent grade. There should be a minimum of 5 feet of horizontal cover as measured from the outside edge of the footing.
- e. Any live or dead loads which will transmit a force to the wall, refer to Figure No. 9.

- f. For flexible (yielding) retaining walls, the resultant seismic force on the wall is $8H^2$ and acts at a point $0.6H$ up from the base of the wall. This force has been estimated using the Mononobe-Okabe method of analysis as modified by Whitman (1990), and assumes a yielding wall condition.
- g. For rigid (non-yielding) retaining walls, the resultant seismic force on the wall is $12H^2$ and acts at a point $0.6H$ up from the base of the wall.

Please note: Should the slope behind the retaining walls be other than shown in Table No.4, supplemental design criteria will be provided for the active earth or at rest pressures for the particular slope angle.

59. The above criteria are based on **fully drained conditions**. Therefore, we recommend that permeable material meeting the State of California Standard Specification Section 68-1.025, Class 1, Type A, be placed behind the wall, with a minimum width of 12 inches and extending for the full height of the wall to within 1 foot of the ground surface. The permeable material should be covered with Mirafi 140N filter fabric or equivalent and then compacted native soil placed to the ground surface. A 4 inch diameter perforated rigid plastic drain pipe should be installed within 3 inches of the bottom of the permeable material and be discharged to a suitable, approved location such as the project storm drain system. The perforations should be located and oriented on the lower half of the pipe. Neither the pipe nor the permeable material should be wrapped in filter fabric. Please refer to Figure No. 10, Typical Retaining Wall Drain Detail.

60. The area behind the wall and beyond the permeable material should be compacted with approved material to a minimum relative dry density of 90%.

SURFACE DRAINAGE

61. Following completion of the project we recommend that storm drainage provisions and performance of permanent erosion control measures be closely observed through the first season of significant rainfall, to determine if these systems are performing adequately and, if necessary, resolve any unforeseen issues.

62. Surface water must not be allowed to pond or be trapped adjacent to the building foundations nor on the building pad nor in the parking areas.

63. All roof eaves should be guttered, with the outlets from the downspouts provided with adequate capacity to carry the storm water from the structures to reduce the possibility of soil saturation and erosion. The connection should be in a closed conduit which discharges at an approved location away from the structures and the graded area. The discharge location should not be located at the top of, or on the face of any topographic slopes. We would recommend a discharge point which is at least 10 feet down slope of any foundation or fill areas.

64. Final grades should be provided with a positive gradient away from all foundations in order to provide for rapid removal of the surface water from the foundations to an adequate discharge point. Soil grades should slope away from foundation areas at least 5 percent for the first 10 feet. Impervious surface areas should slope away from foundations at least 2 percent for the first 10 feet. The Project Civil Engineer, Architect or Building Designer should refer to 2007 CBC Section 1803.3 for further information. Concentrations of surface water runoff should be handled by providing necessary structures, such as paved ditches, catch basins, etc.

65. Cut and fill slopes shall be constructed so that surface water will not be allowed to drain over the top of the slope face. This may require berms along the top of fill slopes and surface drainage ditches above cut slopes. All cut, fill and disturbed native slope areas should be hydro-seeded or other means of erosion control provided, as determined by the Project Civil Engineer.

66. Irrigation activities at the site should not be done in an uncontrolled or unreasonable manner.

67. The building and surface drainage facilities must not be altered nor any filling or excavation work performed in the area without first consulting Pacific Crest Engineering Inc. Surface drainage improvements developed by the project civil engineer must be maintained by the property owner at all times, as improper drainage provisions can produce undesirable affects.

PAVEMENT DESIGN

68. The design of the pavement section was beyond our scope of services for this project. To have the selected pavement sections perform to their greatest efficiency, it is very important that the following items be considered:

- a. Properly scarify and moisture condition the upper 8 inches of the subgrade soil and compact it to a minimum of 95% of its maximum dry density, at a moisture content 1 to 3% over the optimum moisture content for the soil.
- b. Provide sufficient gradient to prevent ponding of water.
- c. Use only quality materials of the type and thickness (minimum) specified. All aggregate base and subbase must meet Caltrans Standard Specifications for Class 2 materials, and be angular in shape. All Class 2 aggregate base should be ¾ inch maximum in aggregate size.
- d. The use of “recycled” materials, such as asphaltic concrete for aggregate base or subbase is not recommended.

EXHIBIT 16-A

- e. Compact the base and subbase uniformly to a minimum of 95% of its maximum dry density.
- f. Use ½ inch maximum, Type “A” medium graded asphaltic concrete. Place the asphaltic concrete only during periods of fair weather when the free air temperature is within prescribed limits by Cal Trans Specifications.
- g. Place ¼ gallon per square yard of SG-70 prime coat over the aggregate base section, prior to placement of the asphaltic concrete.
- h. **Porous pavement systems which consist of porous paving blocks, asphaltic concrete or concrete are generally not recommended due to the potential for saturation of the subgrade soils and resulting increased potential for a shorter pavement life. At a minimum, porous pavement systems should include a layer of Mirafi HP370 geotextile fabric placed on the subgrade soil beneath the porous paving section. These pavement systems should only be used with the understanding by the Owner of the increased potential for pavement cracking, rutting, potholes, etc.**
- i. Maintenance should be undertaken on a routine basis.

SOIL CORROSIVITY

69. Corrosivity tests were run on one representative surface soil sample collected on the project site. These results are summarized as follows:

TABLE No.5, Corrosivity Test Summary

Sample	Soil Resistivity	Chloride mg/kg	Sulfate (water soluble)	pH
	Ohm-cm		mg/kg	
2-1-1	3737	8	<5	7.6

70. Cal Trans considers a site to be corrosive to foundation elements if one or more of the following conditions exist at the site:

- a. The soil resistivity is less than 1,000 ohm-cm
- b. Chloride concentration is greater than or equal to 500 mg/Kg (ppm)
- c. Sulfate concentration is greater than or equal to 2000 mg/Kg (ppm)
- d. The soil pH is 5.5 or less

Refer to Cal Trans Corrosion Guidelines, version 1.0 (September, 2003) for additional information.

EXHIBIT 16-A

Pueblo Water Resources
April 30, 2009

Page 19
Project No. 0922-M242-E12

71. Based on the results of the chloride, sulfate and pH, it appears that the conditions in the shallow existing soil should be assumed to be non-corrosive based on Cal Trans guidelines. The corrosion potential for any imported select fill should also be checked for corrosivity.

72. Please refer to Appendix A for the specific results of the corrosivity testing by the analytical laboratory.

PLAN REVIEW

73. We respectfully request an opportunity to review the project plans and specifications during preparation and before bidding to ensure that the recommendations of this report have been included and to provide additional recommendations, if needed. These plan review services are also typically required by the reviewing agency. Misinterpretation of our recommendations or omission of our requirements from the project plans and specifications may result in changes to the project design during the construction phase, with the potential for additional costs and delays in order to bring the project into conformance with the requirements outlined within this report. Services performed for review of the project plans and specifications are considered "post-report" services and billed on a "time and materials" fee basis in accordance with our latest Standard Fee Schedule.

LIMITATIONS AND UNIFORMITY OF CONDITIONS

1. This Geotechnical Investigation was prepared specifically for you and for the specific project and location described in the body of this report. This report and the recommendations included herein should be utilized for this specific project and location exclusively. This Geotechnical Investigation should not be applied to nor utilized on any other project or project site. Please refer to the ASFE "Important Information about Your Geotechnical Engineering Report" attached with this report.
2. The recommendations of this report are based upon the assumption that the soil conditions do not deviate from those disclosed in the borings. If any variations or undesirable conditions are encountered during construction, or if the proposed construction will differ from that planned at the time, our firm should be notified so that supplemental recommendations can be provided.
3. This report is issued with the understanding that it is the responsibility of the owner, or his representative, to ensure that the information and recommendations contained herein are called to the attention of the Architects and Engineers for the project and incorporated into the plans, and that the necessary steps are taken to ensure that the Contractors and Subcontractors carry out such recommendations in the field.
4. The findings of this report are valid as of the present date. However, changes in the conditions of a property can occur with the passage of time, whether they are due to natural process or the works of man, on this or adjacent properties. In addition, changes in applicable or appropriate standards occur, whether they result from legislation or the broadening of knowledge. Accordingly, the findings of this report may be invalidated, wholly or partially, by changes outside of our control. This report should therefore be reviewed in light of future planned construction and then current applicable codes. This report should not be considered valid after a period of two (2) years without our review.
5. This report was prepared upon your request for our services in accordance with currently accepted standards of professional geotechnical engineering practice. No warranty as to the contents of this report is intended, and none shall be inferred from the statements or opinions expressed.
6. The scope of our services mutually agreed upon for this project did not include any environmental assessment or study for the presence of hazardous or toxic materials in the soil, surface water, groundwater, or air, on or below or around this site.

Important Information About Your Geotechnical Engineering Report

Subsurface problems are a principal cause of construction delays, cost overruns, claims, and disputes.

The following information is provided to help you manage your risks.

Geotechnical Services Are Performed for Specific Purposes, Persons, and Projects

Geotechnical engineers structure their services to meet the specific needs of their clients. A geotechnical engineering study conducted for a civil engineer may not fulfill the needs of a construction contractor or even another civil engineer. Because each geotechnical engineering study is unique, each geotechnical engineering report is unique, prepared *solely* for the client. No one except you should rely on your geotechnical engineering report without first conferring with the geotechnical engineer who prepared it. *And no one — not even you — should apply the report for any purpose or project except the one originally contemplated.*

Read the Full Report

Serious problems have occurred because those relying on a geotechnical engineering report did not read it all. Do not rely on an executive summary. Do not read selected elements only.

A Geotechnical Engineering Report Is Based on A Unique Set of Project-Specific Factors

Geotechnical engineers consider a number of unique, project-specific factors when establishing the scope of a study. Typical factors include: the client's goals, objectives, and risk management preferences; the general nature of the structure involved, its size, and configuration; the location of the structure on the site; and other planned or existing site improvements, such as access roads, parking lots, and underground utilities. Unless the geotechnical engineer who conducted the study specifically indicates otherwise, do not rely on a geotechnical engineering report that was:

- not prepared for you,
- not prepared for your project,
- not prepared for the specific site explored, or
- completed before important project changes were made.

Typical changes that can erode the reliability of an existing geotechnical engineering report include those that affect:

- the function of the proposed structure, as when it's changed from a parking garage to an office building, or from a light industrial plant to a refrigerated warehouse,

- elevation, configuration, location, orientation, or weight of the proposed structure,
- composition of the design team, or
- project ownership.

As a general rule, *always* inform your geotechnical engineer of project changes—even minor ones—and request an assessment of their impact. *Geotechnical engineers cannot accept responsibility or liability for problems that occur because their reports do not consider developments of which they were not informed.*

Subsurface Conditions Can Change

A geotechnical engineering report is based on conditions that existed at the time the study was performed. *Do not rely on a geotechnical engineering report* whose adequacy may have been affected by: the passage of time; by man-made events, such as construction on or adjacent to the site; or by natural events, such as floods, earthquakes, or groundwater fluctuations. *Always* contact the geotechnical engineer before applying the report to determine if it is still reliable. A minor amount of additional testing or analysis could prevent major problems.

Most Geotechnical Findings Are Professional Opinions

Site exploration identifies subsurface conditions only at those points where subsurface tests are conducted or samples are taken. Geotechnical engineers review field and laboratory data and then apply their professional judgment to render an opinion about subsurface conditions throughout the site. Actual subsurface conditions may differ—sometimes significantly—from those indicated in your report. Retaining the geotechnical engineer who developed your report to provide construction observation is the most effective method of managing the risks associated with unanticipated conditions.

A Report's Recommendations Are *Not* Final

Do not overrely on the construction recommendations included in your report. *Those recommendations are not final*, because geotechnical engineers develop them principally from judgment and opinion. Geotechnical engineers can finalize their recommendations only by observing actual

subsurface conditions revealed during construction. *The geotechnical engineer who developed your report cannot assume responsibility or liability for the report's recommendations if that engineer does not perform construction observation.*

A Geotechnical Engineering Report Is Subject to Misinterpretation

Other design team members' misinterpretation of geotechnical engineering reports has resulted in costly problems. Lower that risk by having your geotechnical engineer confer with appropriate members of the design team after submitting the report. Also retain your geotechnical engineer to review pertinent elements of the design team's plans and specifications. Contractors can also misinterpret a geotechnical engineering report. Reduce that risk by having your geotechnical engineer participate in prebid and preconstruction conferences, and by providing construction observation.

Do Not Redraw the Engineer's Logs

Geotechnical engineers prepare final boring and testing logs based upon their interpretation of field logs and laboratory data. To prevent errors or omissions, the logs included in a geotechnical engineering report should *never* be redrawn for inclusion in architectural or other design drawings. Only photographic or electronic reproduction is acceptable, *but recognize that separating logs from the report can elevate risk.*

Give Contractors a Complete Report and Guidance

Some owners and design professionals mistakenly believe they can make contractors liable for unanticipated subsurface conditions by limiting what they provide for bid preparation. To help prevent costly problems, give contractors the complete geotechnical engineering report, *but* preface it with a clearly written letter of transmittal. In that letter, advise contractors that the report was not prepared for purposes of bid development and that the report's accuracy is limited; encourage them to confer with the geotechnical engineer who prepared the report (a modest fee may be required) and/or to conduct additional study to obtain the specific types of information they need or prefer. A prebid conference can also be valuable. *Be sure contractors have sufficient time* to perform additional study. Only then might you be in a position to give contractors the best information available to you, while requiring them to at least share some of the financial responsibilities stemming from unanticipated conditions.

Read Responsibility Provisions Closely

Some clients, design professionals, and contractors do not recognize that geotechnical engineering is far less exact than other engineering disciplines. This lack of understanding has created unrealistic expectations that

have led to disappointments, claims, and disputes. To help reduce the risk of such outcomes, geotechnical engineers commonly include a variety of explanatory provisions in their reports. Sometimes labeled "limitations" many of these provisions indicate where geotechnical engineers' responsibilities begin and end, to help others recognize their own responsibilities and risks. *Read these provisions closely.* Ask questions. Your geotechnical engineer should respond fully and frankly.

Geoenvironmental Concerns Are Not Covered

The equipment, techniques, and personnel used to perform a *geoenvironmental* study differ significantly from those used to perform a *geotechnical* study. For that reason, a geotechnical engineering report does not usually relate any geoenvironmental findings, conclusions, or recommendations; e.g., about the likelihood of encountering underground storage tanks or regulated contaminants. *Unanticipated environmental problems have led to numerous project failures.* If you have not yet obtained your own geoenvironmental information, ask your geotechnical consultant for risk management guidance. *Do not rely on an environmental report prepared for someone else.*

Obtain Professional Assistance To Deal with Mold

Diverse strategies can be applied during building design, construction, operation, and maintenance to prevent significant amounts of mold from growing on indoor surfaces. To be effective, all such strategies should be devised for the *express purpose* of mold prevention, integrated into a comprehensive plan, and executed with diligent oversight by a professional mold prevention consultant. Because just a small amount of water or moisture can lead to the development of severe mold infestations, a number of mold prevention strategies focus on keeping building surfaces dry. While groundwater, water infiltration, and similar issues may have been addressed as part of the geotechnical engineering study whose findings are conveyed in this report, the geotechnical engineer in charge of this project is not a mold prevention consultant; ***none of the services performed in connection with the geotechnical engineer's study were designed or conducted for the purpose of mold prevention. Proper implementation of the recommendations conveyed in this report will not of itself be sufficient to prevent mold from growing in or on the structure involved.***

Rely on Your ASFE-Member Geotechnical Engineer for Additional Assistance

Membership in ASFE/The Best People on Earth exposes geotechnical engineers to a wide array of risk management techniques that can be of genuine benefit for everyone involved with a construction project. Confer with your ASFE-member geotechnical engineer for more information.



8811 Colesville Road/Suite G106, Silver Spring, MD 20910
Telephone: 301/565-2733 Facsimile: 301/589-2017
e-mail: info@asfe.org www.asfe.org

Copyright 2004 by ASFE, Inc. Duplication, reproduction, or copying of this document, in whole or in part, by any means whatsoever, is strictly prohibited, except with ASFE's specific written permission. Excerpting, quoting, or otherwise extracting wording from this document is permitted only with the express written permission of ASFE, and only for purposes of scholarly research or book review. Only members of ASFE may use this document as a complement to or as an element of a geotechnical engineering report. Any other firm, individual, or other entity that so uses this document without being an ASFE member could be committing negligent or intentional (fraudulent) misrepresentation.

APPENDIX A

Regional Site Map
Site Map Showing Test Borings
Boring Log Explanation
Log of Test Borings
Caltrans Corrosivity Test Summary
Keyway Detail
Surcharge Pressure Diagram
Typical Retaining Wall Drain Detail



Base Map from Regal Map Company

Pacific Crest Engineering Inc.
444 Airport Blvd., Suite 106
Watsonville, CA 95076

Regional Site Map
Electrical & Chemical Feed Building
Seaside, California

Figure No. 1
Project No. 0922
Date: 4/30/09

Base Map Provided by:
Pueblo Water Resources
Dated February 4, 2009



Not to Scale

Approximate Boring Location

Pacific Crest Engineering Inc.
444 Airport Blvd., Suite 106
Watsonville, CA 95076

Site Map Showing Test Boring Locations
Electrical and Chemical Feed Building
Seaside, California

Figure No. 2
Project No. 0922
Date: 4/30/09

EXHIBIT 16-A

UNIFIED SOIL CLASSIFICATION SYSTEM - ASTM D2488 (Modified)

PRIMARY DIVISIONS		GROUP SYMBOL	SECONDARY DIVISIONS
COARSE GRAINED SOILS MORE THAN HALF OF MATERIAL IS LARGER THAN #200 SIEVE SIZE	GRAVELS MORE THAN HALF OF COARSE FRACTION IS LARGER THAN #4 SIEVE	CLEAN GRAVELS (LESS THAN 5% FINES)	GW Well graded gravels, gravel-sand mixtures, little or no fines
		GRAVELS (MORE THAN 12% FINES)	GP Poorly graded gravels or gravels-sand mixtures, little or no fines
	SANDS MORE THAN HALF OF COARSE FRACTION IS SMALLER THAN #4 SIEVE	CLEAN SANDS (LESS THAN 5% FINES)	GM Silty gravels, gravel-sand-silt mixtures, non-plastic fines
			GC Clayey gravels, gravel-sand-clay mixtures, plastic fines
		SANDS (MORE THAN 12% FINES)	SW Well graded sands, gravelly sands, little or no fines
			SP Poorly graded sands or gravelly sands, little or no fines
FINE GRAINED SOILS MORE THAN HALF OF MATERIAL IS SMALLER THAN #200 SIEVE SIZE	SILTS AND CLAYS LIQUID LIMIT IS LESS THAN 35%	SM Silty sands, sand-silt mixtures, non-plastic fines	
		SC Clayey sands, sand-clay mixtures, plastic fines	
		ML Inorganic silts and very fine clayey sand silty sands, with slight plasticity	
	SILTS AND CLAYS LIQUID LIMIT IS BETWEEN 35% AND 50%	CL Inorganic clays of low to medium plasticity, gravelly, sand, silty or lean clays	
		OL Organic silts and organic silty clays of low plasticity	
		MI Inorganic silts, clayey silts and silty fine sands of intermediate plasticity	
	SILTS AND CLAYS LIQUID LIMIT IS GREATER THAN 50%	CI Inorganic clays, gravelly/sandy clays and silty clays of intermediate plasticity	
		OI Organic clays and silty clays of intermediate plasticity	
		MH Inorganic silts, micaceous or diatomaceous fine sandy or silty soils, elastic silts	
		CH Organic clays of high plasticity, fat clays	
HIGHLY ORGANIC SOILS		OH Organic clays of medium to high plasticity, organic silts	
		PT Peat and other highly organic soils	

BORING LOG EXPLANATION

Depth, ft.	Sample No. and Type	Symbol	SOIL DESCRIPTION	Unified Soil Classification	SPT "N" Value	Plasticity Index	Dry Density, p.c.f.	Moisture % of Dry Wt.	MISC. LAB RESULTS
1			← Ground water elevation						
2	1-1		← Soil Sample Number ← Soil Sampler Size/Type L = 3" Outside Diameter M = 2.5" Outside Diameter T = 2" Outside Diameter ST = Shelby Tube BAG = Bag Sample						
3									
4									
5									

RELATIVE DENSITY

SANDS AND GRAVELS	BLOWS/FOOT
VERY LOOSE	0-4
LOOSE	4-10
MEDIUM DENSE	10-30
DENSE	30-50
VERY DENSE	OVER 50

CONSISTENCY

SILTS AND CLAYS	BLOWS/FOOT
VERY SOFT	0-2
SOFT	2-4
FIRM	4-8
STIFF	8-16
VERY STIFF	16-32
HARD	OVER 32

Pacific Crest Engineering Inc.
444 Airport Blvd., Suite 106
Watsonville, CA 95076

Boring Log Explanation
Electrical & Chemical Feed Building
Seaside, California

Figure No. 3
Project No. 0922
Date: 4/30/09

EXHIBIT 16-A

LOGGED BY CLR DATE DRILLED 4/17/09 BORING DIAMETER 6" BORING NO. 1

Depth (feet)	Sample No. and Type	Symbol	Soil Description	Unified Soil Classification	SPT "N" Value	Plasticity Index	Dry Density (pcf)	Moisture % of Dry Wt.	Misc. Lab Results
1			Brown Silty SAND, fine to medium grained, sub-angular to sub-rounded shaped, poorly graded, mica flakes scattered throughout the sample, trace coarse grains scattered throughout the sample, damp, hard, (Older Dune Deposits)	SM	35		121.3	8.9	17.1% Passing #200 Sieve
2	1-1								
3	L								
4									
5	1-2		Color changed to dark reddish brown, trace rounded chert pebbles scattered throughout the sample, damp, medium dense		17		108.7	5.4	
6	L								
7									
8			Color change to yellowish tan, slight decrease in coarseness of sand, very fine to medium grained, slightly damp, medium dense		18		108.4	2.0	
9									
10	1-3								
11	L								
12			Slight reddish tan mottling scattered throughout the sample, slight increase in coarseness of sand, damp, medium dense		19		104.9	4.4	
13									
14									
15	1-4								
16	L		Lack of mottling, slight decrease in coarseness of sand, damp, medium dense		30		100.2	3.5	
17									
18									
19									
20	1-5								
21	L								
22									
23									
24									

Pacific Crest Engineering Inc.
444 Airport Blvd., Suite 106
Watsonville, CA 95076

Log of Test Borings
Electrical & Chemical Feed Building
Seaside, California

Figure No. 4
Project No. 0922
Date: 4/30/09

EXHIBIT 16-A

LOGGED BY CLR DATE DRILLED 4/17/09 BORING DIAMETER 6" BORING NO. 1

Depth (feet)	Sample No. and Type	Symbol	Soil Description	Unified Soil Classification	SPT "N" Value	Plasticity Index	Dry Density (pcf)	Moisture % of Dry Wt.	Misc. Lab Results
25	1-6 L		Yellowish tan SAND, fine to medium grained, trace coarse grains, sub-angular to sub-rounded shaped, mica flakes scattered throughout the sample, poorly graded, damp, medium dense, (Older Dune Deposits)	SP	29		94.0	3.7	1.6% Passing #200 Sieve
26									
27									
28	1-7 L		Lack of coarse grains, slightly damp, very dense		50/6"		103.6	4.0	
29									
30									
31	1-8 L		Slightly damp, very dense		50/5"		103.6	4.2	1.8% Passing #200 Sieve
32									
33									
34			Boring terminated at 36 feet. No groundwater encountered.						
35									
36									
37									
38									
39									
40									
41									
42									
43									
44									
45									
46									
47									
48									

Pacific Crest Engineering Inc.
444 Airport Blvd., Suite 106
Watsonville, CA 95076

Log of Test Borings
Electrical & Chemical Feed Building
Seaside, California

Figure No. 5
Project No. 0922
Date: 4/30/09

EXHIBIT 16-A

LOGGED BY <u>CLR</u> DATE DRILLED <u>4/17/09</u> BORING DIAMETER <u>6"</u> BORING NO. <u>2</u>									
Depth (feet)	Sample No. and Type	Symbol	Soil Description	Unified Soil Classification	SPT "N" Value	Plasticity Index	Dry Density (pcf)	Moisture % of Dry Wt.	Misc. Lab Results
1	2-1 L		Dark brown SAND with Silt, very fine to medium grained, sub-angular to sub-rounded shaped, poorly graded, trace rounded chert pebbles scattered throughout the sample, trace granitic gravel near 3 1/2 feet, mica flakes scattered throughout the sample, damp, medium dense	SP-SM	17				
2									
3									
4									
5	2-2 L		Dark reddish brown SAND with Silt, fine to medium grained, trace coarse grains, sub-angular to sub-rounded shaped, poorly graded, mica flakes scattered throughout the sample, damp, loose, (Older Dune Deposits)	SP-SM	7		110.8	6.4	10.0% Passing #200 Sieve
6									
7									
8	2-3 L		Color change to yellowish tan, trace rounded chert pebbles scattered throughout the sample, slightly damp, medium dense		19		99.4	2.8	
9									
10									
11									
12	2-4 L		Color change to tan, lack of rounded chert pebbles, slightly damp, medium dense		23		99.2	3.2	
13									
14									
15									
16	Boring terminated at 16 1/2 feet. No groundwater encountered.								
17									
18									
19									
20									
21									
22									
23									
24									

Pacific Crest Engineering Inc.
444 Airport Blvd., Suite 106
Watsonville, CA 95076

Log of Test Borings
Electrical & Chemical Feed Building
Seaside, California

Figure No. 6
Project No. 0922
Date: 4/30/09

EXHIBIT 16-A

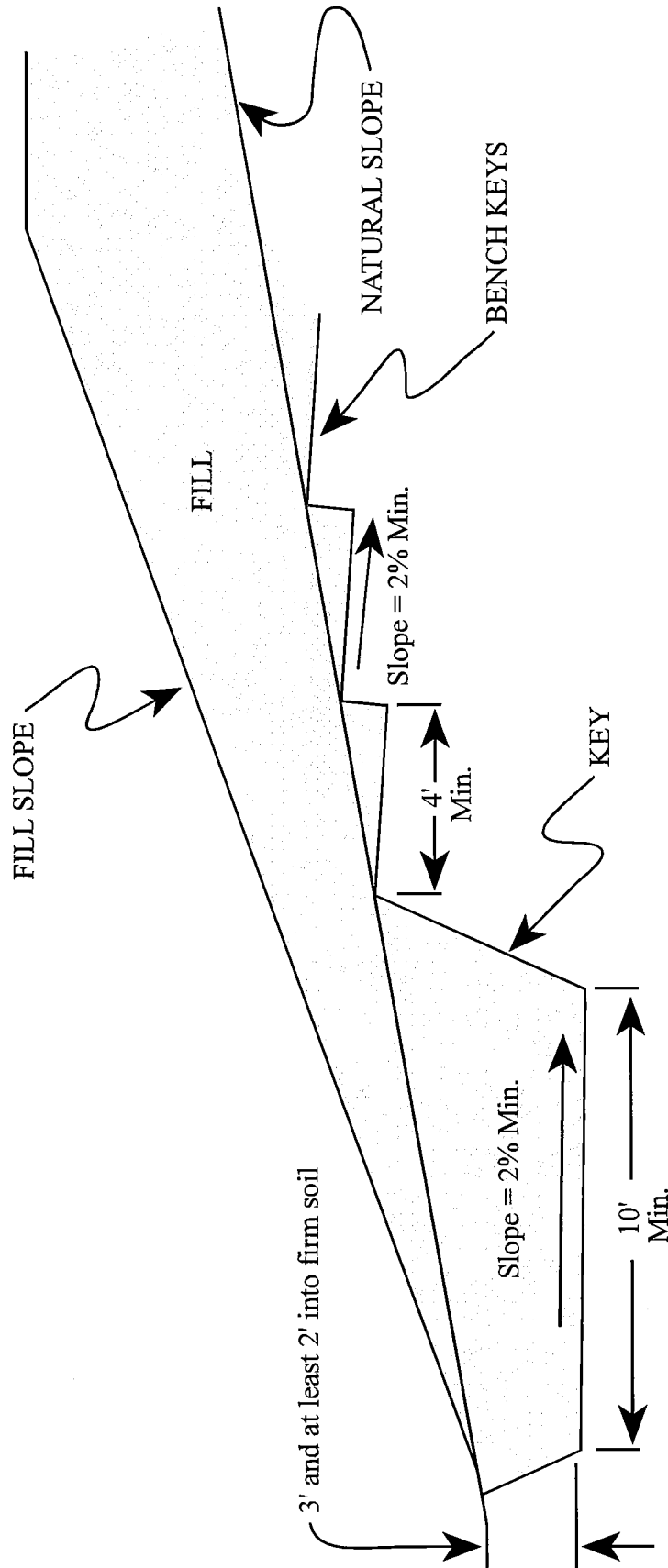

TYPICAL KEY AND BENCHES

not to scale

Pacific Crest Engineering Inc.
444 Airport Blvd., Suite 106
Watsonville, CA 95076

Keyway Detail
Electrical & Chemical Feed Building
Seaside, California

Figure No. 8
Project No. 0922
Date: 4/30/09

LINE LOAD

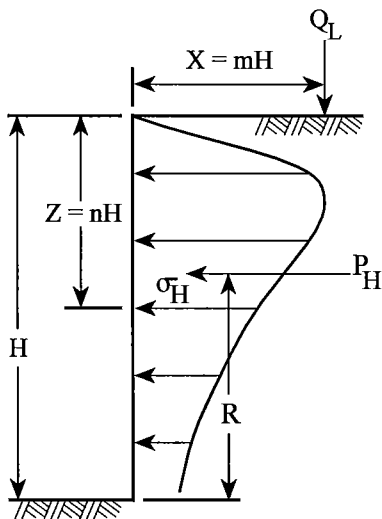
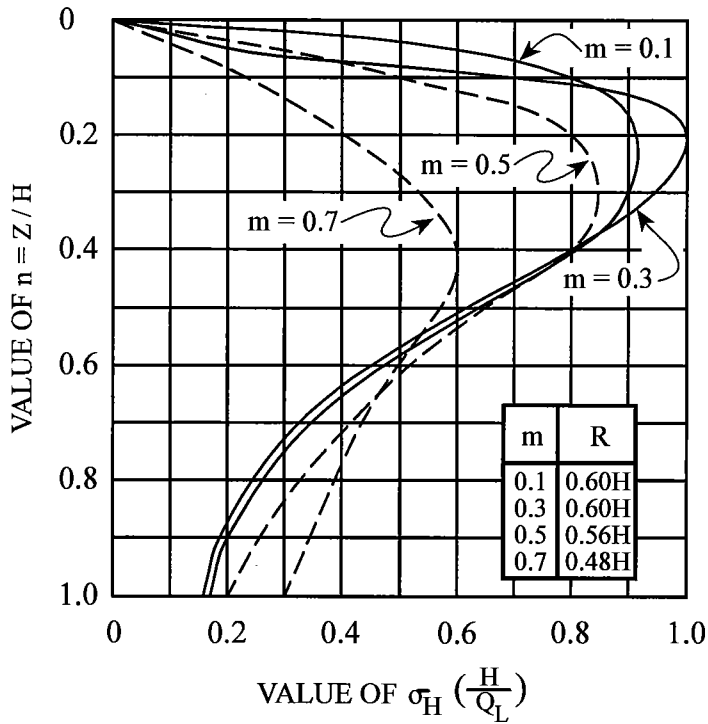

FOR $m \leq 0.4$:

$$\sigma_H \left(\frac{H}{Q_L} \right) = \frac{0.20 n}{(0.16 + n^2)^2}$$

$$P_H = 0.55 Q_L$$

FOR $m > 0.4$:

$$\sigma_H \left(\frac{H}{Q_L} \right) = \frac{1.28 m^2 n}{(m^2 + n^2)^2}$$

$$\text{RESULTANT } P_H = \frac{0.64 Q_L}{(m^2 + 1)}$$

PRESSURES FROM LINE LOAD Q_L

(BOISSINESQ EQUATION MODIFIED BY EXPERIMENT)

REFERENCE: Design Manual
NAVFAC DM-7.02
Figure 11
Page 7.2-74

POINT LOAD

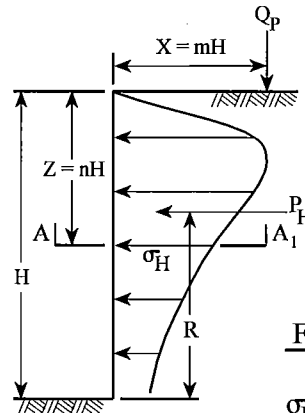
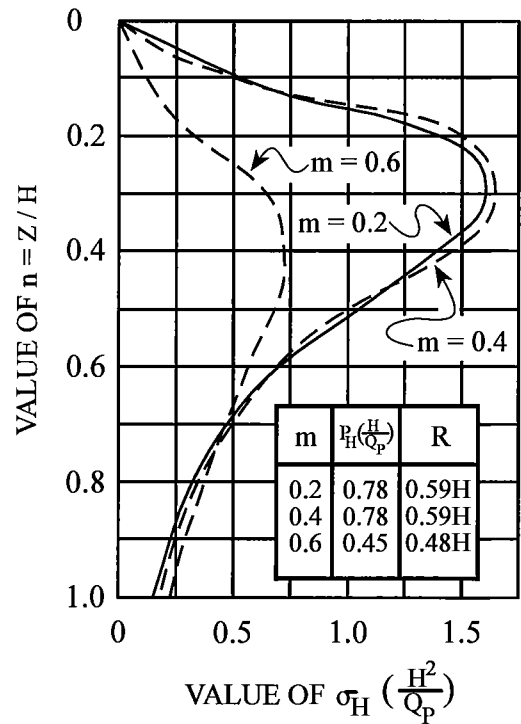

FOR $m \leq 0.4$:

$$\sigma_H \left(\frac{H^2}{Q_P} \right) = \frac{0.28 n^2}{(0.16 + n^2)^3}$$

FOR $m > 0.4$:

$$\sigma_H \left(\frac{H^2}{Q_P} \right) = \frac{1.77 m^2 n^2}{(m^2 + n^2)^3}$$

$$\sigma_H^1 = \sigma_H \cos^2(1.1 \theta)$$

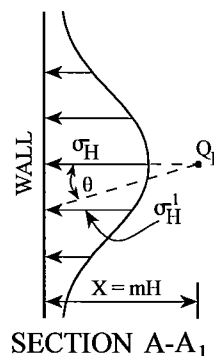

PRESSURES FROM POINT LOAD Q_P

(BOISSINESQ EQUATION MODIFIED BY EXPERIMENT)

EXHIBIT 16-A

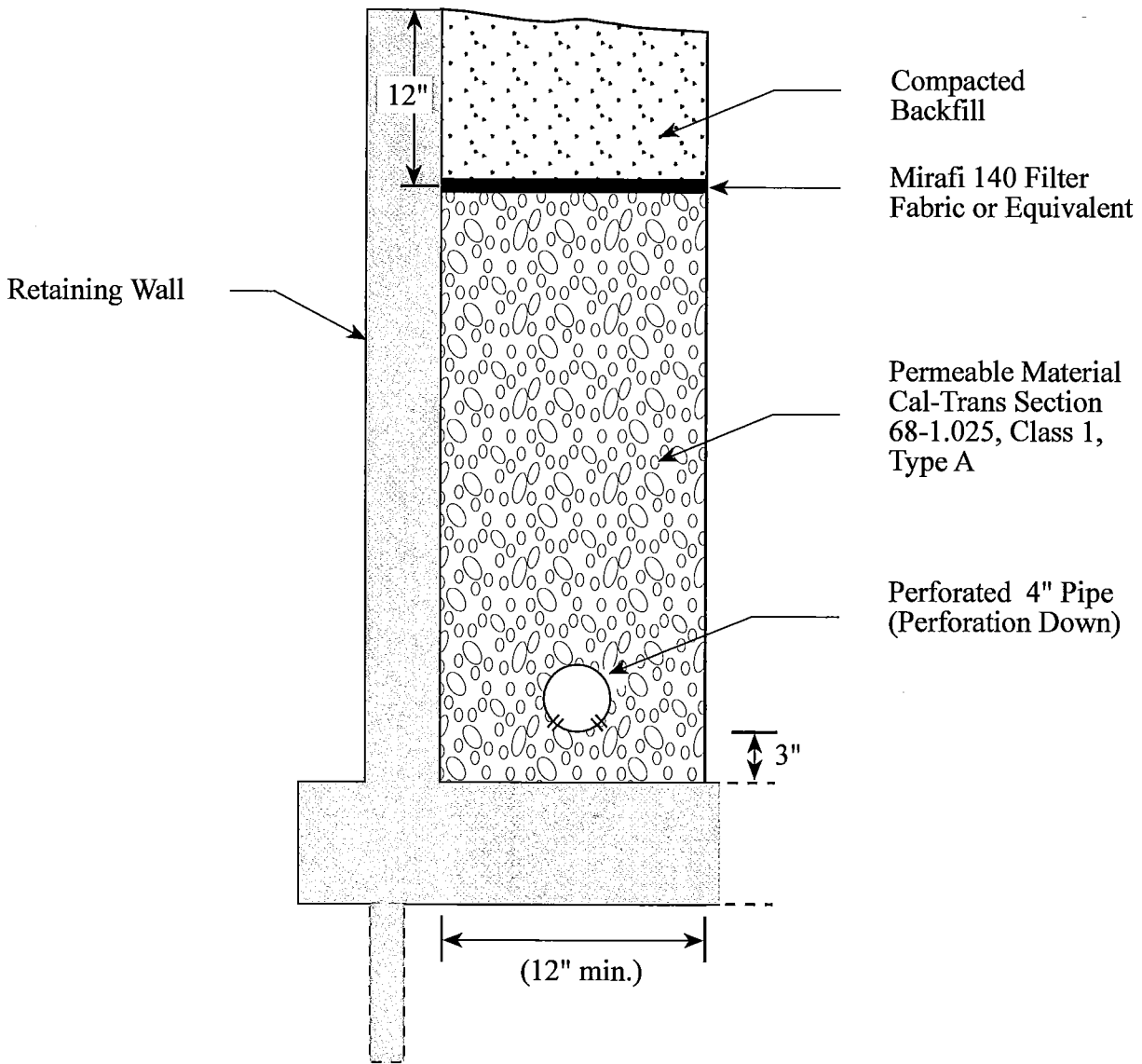

Not to Scale

February 4, 2018

Project No. 0922.1-M242-E12

Revised February 23, 2018

Mr. Steve Tanner, PE
Pueblo Water Resources
4478 Market Street, Suite 705
Ventura, CA 93003

Subject: Update to Geotechnical Investigation Report
MPWMD – ASR Site Expansion
Backflush Pit at Santa Margarita Well Site
1910 General Jim Moore Boulevard
Seaside, California

Reference: Pacific Crest Engineering, Inc.
Geotechnical Investigation For New Electrical & Chemical Feed Building
Project No. 0922-M242-E12
Dated April 30, 2009

Dear Mr. Tanner,

As requested, we are providing this addendum letter to the referenced geotechnical investigation report that was prepared by our firm in 2009. The purpose for this letter is to evaluate the planned improvements in order to develop geotechnical recommendations pertinent to the proposed pond expansion and update our 2009 report to include the most recent CBC design criteria. The recommendations outlined below are based on our review of the referenced soil report, preliminary grading and drainage plans provided by your firm, and a visit to the site on January 30, 2018.

Based on our review of Preliminary Grading and Drainage Plan and Cross Section sheets dated 4/17/17, it is our understanding that the proposed improvements will consist of expanding the existing backflush pit to the north, construction of a CMU wall adjacent to General Jim Moore Boulevard, and construction of a chemical loading rack along the northwest corner of the expanded pond. Also proposed are construction of two 30" treated water lines and

The north and west side of the expanded pond slopes will be constructed of cut and fill. The east side slopes will be comprised entirely of cuts up to 11 feet in height. The proposed pond slopes are currently designed at 1:1 horizontal to vertical.

The CMU wall will screen views from General Jim Moore Boulevard and will retain inboard fills generated as part of the pond expansion. The proposed chemical loading rack will be supported by a reinforced concrete slab and will be accessed by a new AC roadway the connects to the existing entry road. The

new road and chemical loading rack pad will be underlain by fill ranging from approximately one to five feet in depth.

UPDATED RECOMMENDATIONS

Based on our review of the proposed improvement plans, it is our opinion that, except as modified below, the recommendations of our 2009 geotechnical report continue to remain applicable to this project. All recommendations of the 2009 Geotechnical Report and this Update Report should be closely followed during the design and construction phases of the project. Any unexplained discrepancies between the original report and this update should be brought to the immediate attention of the Geotechnical Engineer for clarification.

In our opinion unreinforced 1:1 horizontal to vertical side slopes for the proposed backflush pit are too steep for long term stability under saturated conditions. Side slopes constructed to these gradients without slope reinforcement will be subject to erosion and sloughing, requiring continued maintenance over the lifetime of the project, and could potentially undermine improvements adjacent to the top of slope.

The proposed pond expansion will require raising existing grades along the north and west sides with up to 4 to 5 feet of fill. In addition, existing grades at the base of the expanded pond will be lowered by about 5 to 6 feet. This will create a condition where the pond slopes will be comprised of cut overlain by fill. As recommended in the soil report, fill slopes to be constructed above cut slopes should be set back a minimum of 8 feet horizontally from the top of the cut slope. This is especially important where structural improvements such as the chemical loading rack, new access roads or new utility corridors will come within close proximity to the pond slopes. Alternatively, the slope below the chemical loading rack pad may be constructed of engineered fill at a maximum gradient of 2:1 horizontal. The fill slope should be constructed in accordance with the recommendations of the 2009 geotechnical report and Figure No. 1 attached.

If space constraints preclude the construction of 2:1 fill slopes, the pond slope below the chemical loading rack area may be constructed at a maximum gradient of 1:1 horizontal to vertical provided the slope is designed and constructed as a reinforced soil slope (RSS) with geosynthetic reinforcing. Please refer to Figure No. 2 for a general schematic of a reinforced soil slope. The geosynthetic reinforcement layers should extend a minimum length of 1.0 times the total vertical height of the RSS system, with vertical spacing not exceeding 2 feet. The reinforcing should be wrapped at the slope face with a minimum 3-foot overlap as shown on Figure No. 2. Final spacing, reinforcing type and length should be determined by the project design professional. All engineered fill should be placed and compacted in accordance with the recommendations of our 2009 report. It is anticipated that the onsite soils will be suitable for use as engineered fill for this project.

Reinforced soil slopes should be constructed where ever structural, roadway and/or pipelines will come within 20 feet of the adjacent slope face, or 10 feet beyond the perimeter of the chemical loading rack pad, whichever is greater. The RSS system should be faced with an erosion control blanket as determined by



EXHIBIT 16-A

the project civil engineer. The performance of erosion control measures should be routinely monitored and areas where the geosynthetic has been exposed should be repaired and replanted.

In other areas of the backflush pit expansion where there is low potential for undermining adjacent improvements consideration should be given to constructing side slopes at gradients no steeper than 2:1 horizontal to vertical. Where site constraints preclude these gradients the Owner should be made aware of the potential for erosion, sloughing and long term instability requiring continued maintenance. As a minimum, erosion control measures should be considered for oversteepened pond slopes.

Pipelines or other utility improvements should be setback a minimum of 15 feet horizontally from the outboard edge of all unreinforced slopes. We note that 30" RW line may be in close proximity to the backcut for a RSS slope below the chemical loading rack pad and this will need to be considered when planning backfill methods for the utility trench. Care should be taken not to damage the reinforcing layers when performing earthwork adjacent to RSS slopes.

The proposed CMU wall may be designed and constructed using the lateral earth pressures and foundation design criteria provided in the 2009 geotechnical report for fully drained conditions.

The following updated CBC design criteria should be used in the design of structural improvements for this project. Structural improvements should be designed and constructed in accordance with the recommendations of the 2009 geotechnical report and the most recent CBC requirements as outlined below.

Table No. 1 - 2016 CBC Seismic Design Parameters¹

Seismic Design Parameter	ASCE 7-10 Value
Site Class	D
Spectral Acceleration for Short Periods	$S_s = 1.471g$
Spectral Acceleration for 1-second Period	$S_1 = 0.529g$
Short Period Site Coefficient	$F_a = 1.0$
1-Second Period Site Coefficient	$F_v = 1.5$
MCE Spectral Response Acceleration for Short Period	$S_{MS} = 1.471g$
MCE Spectral Response Acceleration for 1-Second Period	$S_{M1} = 0.794g$
Design Spectral Response Acceleration for Short Period	$S_{DS} = 0.981g$
Design Spectral Response Acceleration for 1-Second Period	$S_{D1} = 0.529g$
Seismic Design Category ²	D

Note 1: Design values have been obtained by using the Ground Motion Parameter Calculator available on the USGS website at <http://earthquake.usgs.gov/hazards/designmaps/usdesign.php>.

Note 2: The Seismic Design Category assumes a structure with Risk Category I, II or III occupancy as defined by Table 1604.5 of the 2016 CBC. Pacific Crest Engineering Inc. should be contacted for revised Table 1 seismic design parameters if the proposed structure has a different occupancy rating than that assumed.



EXHIBIT 16-A

Santa Margarita Well Site ASR Pond Expansion
February 4, 2018
Revised February 23, 2018

Project No. 0922.1-M242-E12

This report is issued as an addendum to our April 30, 2009 geotechnical report and should be reviewed in conjunction with that document. Except as modified herein, all recommendations of the April 2009 geotechnical report remain applicable to the design and construction of the project.

We respectfully request an opportunity to review the project plans and specifications during preparation and before bidding to ensure that the recommendations of this report have been included and to provide additional recommendations, if needed. These plan review services are also typically required by the reviewing agency. Misinterpretation of our recommendations or omission of our requirements from the project plans and specifications may result in changes to the project design during the construction phase, with the potential for additional costs and delays in order to bring the project into conformance with the requirements outlined within this report. Services performed for review of the project plans and specifications are considered "post-report" services and billed on a "time and materials" fee basis in accordance with our latest Standard Fee Schedule.

We appreciate the opportunity to be of service. If you have any questions regarding this update letter, please contact our office.

Sincerely,

PACIFIC CREST ENGINEERING INC.



Elizabeth M. Mitchell, GE
President/Principal Geotechnical Engineer
GE 2718, Expires 12/13/18

Copies: 2 to Client



EXHIBIT 16-A

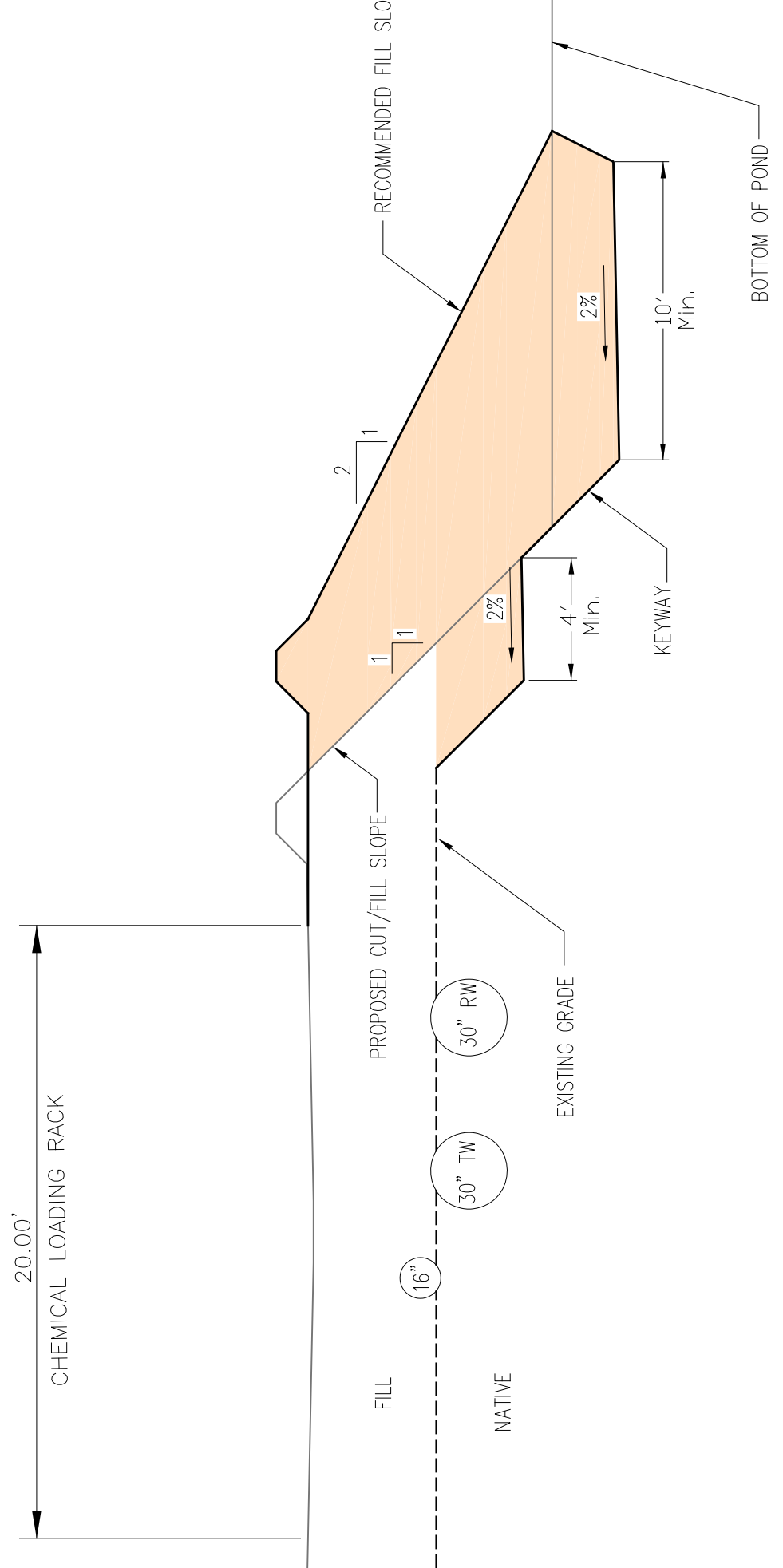

Pacific Crest Engineering Inc.
 444 Airport Blvd., Suite 106
 Watsonville, CA 95076
 Ph: (831) 763-6191
 Fax: (831) 763-6195

SANTA MARGARITA WELL SITE
 ASR SITE EXPANSION
 CROSS SECTION A-A'

Scale: 1"=5'
 Drawn By: MJM 2/5/18
 Project No: 0922.1
 PM: EM
 Rev: 0

Drawing No:
FIGURE 1

EXHIBIT 16-A

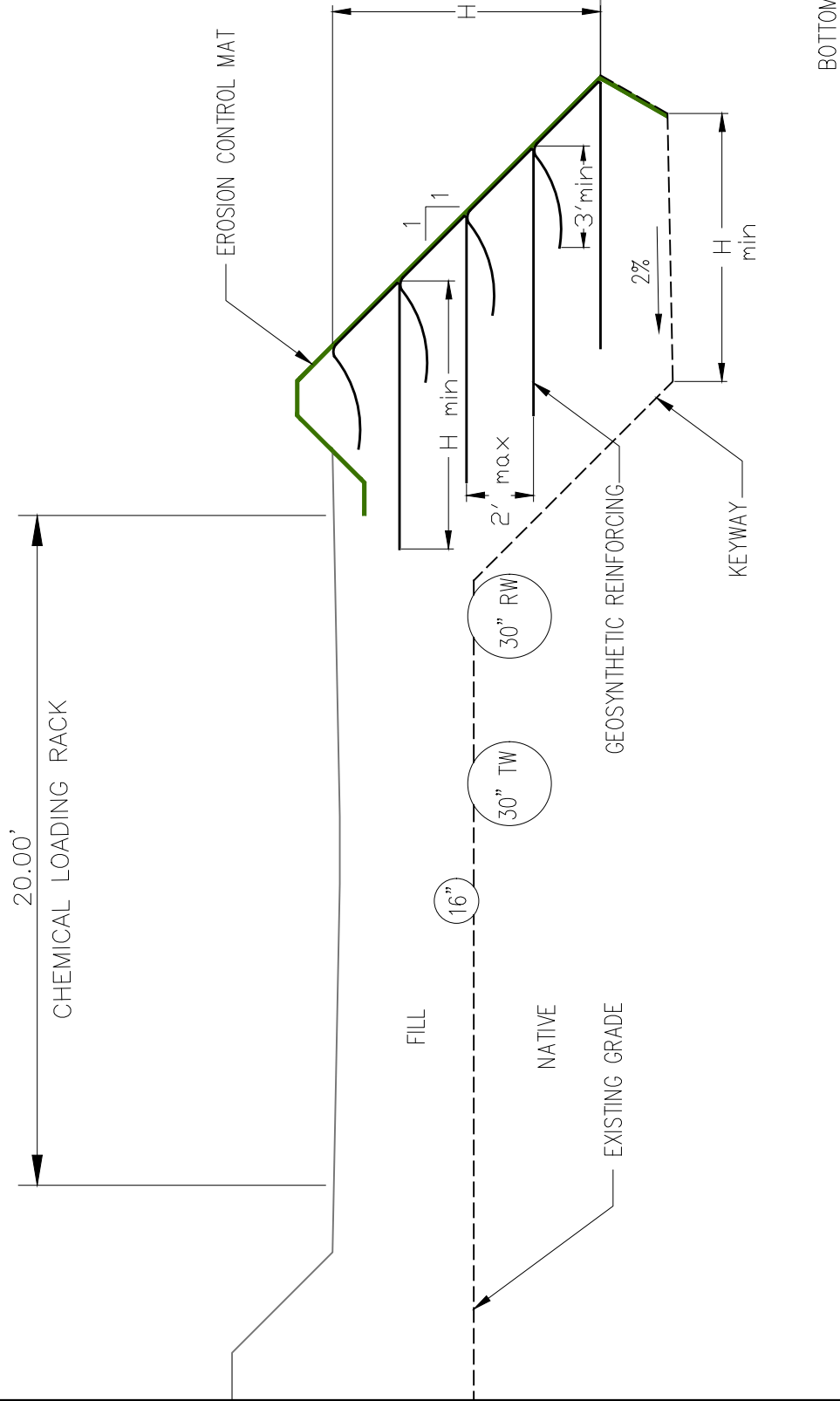

Pacific Crest Engineering Inc.

444 Airport Blvd., Suite 106
 Watsonville, CA 95076
 Ph: (831) 763-6191
 Fax: (831) 763-6195

SANTA MARGARITA WELL SITE
 ASR SITE EXPANSION

CROSS SECTION A-A'

Scale:
 1"=5'

Drawn By:
 MJM 2/23/18

Project No:
 0922.1

PM: EM
 Rev: 0

Drawing No:

FIGURE 2

EXHIBIT 16-A

Backflush Basin Expansion

ATTACHMENT 4

APPROVED MMRP FOR THE AQUIFER STORAGE AND RECOVERY PROJECT

EXHIBIT 16-A

Backflush Basin Expansion

This page is intentionally blank.

Revised Mitigation Monitoring Plan

CEQA requires that when a lead agency makes findings of significant effects identified in an EIR, it must also adopt a program for reporting and monitoring mitigation measures that were adopted or made conditions of project approval. NEPA requires that the lead agency must include a monitoring and enforcement program for each mitigation measure identified in an EA or Environmental Impact Statement. The objectives of the monitoring are to:

- ensure that mitigation measures are properly implemented,
- provide feedback to agency staff and decision makers about the effectiveness of their actions,
- provide learning opportunities for improving mitigation measures on future projects, and
- identify the need for enforcement action before irreversible environmental damage occurs.

This Mitigation Monitoring Plan (MMP) is designed to ensure that the mitigation measures identified in the EIR/EA are fully implemented. The MMP contains each mitigation measure found in the EIR/EA and is organized by topic in the same order as the contents of the EIR/EA. The agency responsible for monitoring is identified for each measure. The MMP will be considered by the MPWMD in conjunction with project review.

Vegetation and Wildlife

Mitigation Measure BIO-1: Minimize or Prevent Disturbance to Adjacent NRMA

To prevent disturbance of the adjacent NRMA, management measures will be carried out during project construction and operation to minimize construction effects and the potential for introducing invasive nonnative species. The construction contractor will implement BMPs to prevent the spread outside the construction area of construction materials, oil and fuel, sidecast soil, dust, or water runoff. All invasive nonnative plants, such as iceplant or pampas grass, will be removed from the construction area prior to site disturbance to avoid the spread of plant fragments or seeds. A firebreak consistent with the requirements of the Presidio of Monterey Fire Department and acceptable to the City of

Seaside Fire Department will be located and maintained by MPWMD between the well site and the adjacent NRMA.

Monitoring: MPWMD is responsible for ensuring that this mitigation measure is implemented. MPWMD will conduct on-site monitoring during construction.

Mitigation Measure BIO-2: Remove Trees and Shrubs during the Nonbreeding Season for Most Birds (September 1 To February 15)

Clearing of the site for inspection, maintenance and cleaning, and construction of the well and associated facilities and the pipeline, and subsequent inspection and maintenance and cleaning activities will result in the removal of trees and shrubs that provide suitable nesting habitat for migratory birds. To avoid the loss of active migratory bird nests, tree and shrub removal will be conducted only during the nonbreeding season for migratory birds (generally September 1 to February 15). Removing woody vegetation during the nonbreeding season will ensure that active nests will not be destroyed by removal of trees supporting or adjacent to active nests.

Monitoring: Prior to initiation of construction activities, MPWMD will ensure that this mitigation measure is implemented. MPWMD is responsible for ensuring compliance for the duration of the project.

Aquatic Resources

Mitigation Measure AR-1: Conduct Annual Survey Below River Mile 5.5 and Monitor River Flow in January–June Period.

Even though the project impact is beneficial and no mitigation is required, the following mitigation is proposed to ensure adequate monitoring of the lower Carmel River. At the beginning of each diversion season and following each storm with a peak flow greater than 3,000 cfs, MPWMD shall conduct a survey of the river channel below RM 5.5 and identify five specific locations where low flows or the channel configuration could potentially block or impair upstream migration of adult steelhead.¹ During the period from December 1 through May 31 when water is being diverted from the Carmel River and injected into the Seaside Groundwater Basin, MPWMD shall monitor flow at the Highway One Bridge, and water currents, depths, and channel configuration at each of the five sites previously identified. If evidence of impairment or blockage is found, MPWMD shall cease diverting until flow increases or until the channel configuration is modified so as to alleviate the blockage or impairment. In the event that channel conditions improve or deteriorate for more than two seasons, the bypass flow criteria shall be reexamined and may be modified by among between NOAA Fisheries, CDFG, and the MPWMD.

¹ Potential impairment or blockage shall be monitored by measuring water depths at the shallowest points at 2-foot intervals along the crest of riffles. For the purpose of monitoring and assessing the need for channel modifications, the potential for impairment and/or blockage shall be based on the following criteria: **blockage**, if the width and depth of a continuous section is less than 5 feet wide and ≥ 0.6 feet deep; **impaired**, if the width and depth of a continuous section is five to ten feet wide and ≥ 0.6 feet deep, and **no impairment**, if the width and depth of a continuous section is ≥ 10 feet wide and ≥ 0.6 feet deep.

Monitoring: MPWMD is responsible for ensuring that this mitigation measure is implemented. MPWMD will conduct on-site monitoring during project operation.

Mitigation Measure AR-2: Cooperate to Help Develop a Project to Maintain, Recover, or Increase Storage in Los Padres Reservoir and If Needed, Continue Funding Program to Rescue and Rear Isolated Juveniles

To ensure the continued benefit of the Proposed Project to the Carmel River and dependent resources during future low-flow periods, MPWMD will encourage and work with Cal-Am, CDFG, and NOAA Fisheries to investigate and develop a project to improve summer flows and the quality of releases by maintaining, recovering, or increasing storage capacity in the existing Los Padres Reservoir. MPWMD will provide staff expertise and data, as requested. Cal-Am, as owner and operator of Los Padres Dam and Reservoir, is responsible for maintenance of the dam and compliance with existing regulations, including water right conditions. MPWMD will request that Cal-Am develop an updated elevation-capacity curve for Los Padres Reservoir that provides current estimates of the amount of storage capacity available at various elevations in the reservoir area.

In the meantime, MPWMD will continue funding and operation of its program to rescue and rear juvenile steelhead that are stranded downstream of the USGS gaging station at Robles del Rio (RM 14.4). This program is part of MPWMD's mitigation program that was adopted in 1990 when the MPWMD Board certified the MPWMD Water Allocation Program EIR. Without significant progress in maintaining storage capacity in Los Padres Reservoir, the rescue program will be needed in most years.-

Monitoring: Cal-Am is responsible for ensuring that this mitigation measure is implemented. Cal-Am will conduct on-site monitoring of Los Padres Reservoir during project operation. MPWMD will provide staff expertise and data, as requested, and continue funding and operation of its program to rescue and rear juvenile steelhead.

Cultural Resources

Mitigation Measure CR-1: Stop Work If Buried Cultural Deposits Are Encountered during Construction Activities

If buried cultural resources such as chipped stone or groundstone, historic debris, building foundations, or human bone are inadvertently discovered during ground-disturbing activities, the construction contractor will stop work in that area and within a 100-foot radius of the find until a qualified archaeologist can assess the significance of the find and, if necessary, develop appropriate treatment measures. Treatment measures typically include avoidance strategies or mitigation of impacts through data recovery programs such as excavation or detailed documentation.

Monitoring: MPWMD is responsible for ensuring that this mitigation measure is implemented. MPWMD will conduct on-site monitoring during construction.

Mitigation Measure CR-2: Stop Work If Human Remains Are Encountered during Construction Activities

If human skeletal remains are encountered, the construction contractor will notify MPWMD and the county coroner immediately. MPWMD will ensure the construction specifications include this order.

If the county coroner determines that the remains are Native American, the coroner will be required to contact the Native American Heritage Commission (pursuant to Section 7050.5 [c] of the California Health and Safety Code) and the County Coordinator of Indian Affairs. A qualified Jones & Stokes archaeologist will also be contacted immediately.

If human remains are discovered in any location other than a dedicated cemetery, there will be no further excavation or disturbance of the site or any nearby area reasonably suspected to overlie adjacent human remains until:

- the coroner of the county has been informed and has determined that no investigation of the cause of death is required; and
- if the remains are of Native American origin:
 - the descendants of the deceased Native Americans have made a recommendation to the landowner or the person responsible for the excavation work for means of treating or disposing of with appropriate dignity the human remains and any associated grave goods as provided in Public Resources Code Section 5097.98; or
 - the NAHC was unable to identify a descendent or the descendent failed to make a recommendation within 24 hours after being notified by the commission.

According to the California Health and Safety Code, six or more human burials at one location constitute a cemetery (Section 8100), and disturbance of Native American cemeteries is a felony (Section 7052). Section 7050.5 requires that construction or excavation be stopped in the vicinity of discovered human remains until the coroner can determine whether the remains are those of a Native American. If the remains are determined to be Native American, the coroner must contact the NAHC.

Monitoring: MPWMD is responsible for ensuring that this mitigation measure is implemented. MPWMD will conduct on-site monitoring during construction.

Surface and Groundwater Hydrology and Water Quality

Mitigation Measure GWH-1: Comply with Performance Standards in NPDES Permits

All construction activities, vehicle storage, and discharges associated with project construction and operation, including well discharges, shall be accomplished in accordance with NPDES permits from the RWQCB to ensure no degradation of surface or groundwater quality. All performance standards contained in the permit will be met.

Monitoring: MPWMD is responsible for ensuring that this mitigation measure is implemented. MPWMD will conduct on-site monitoring during construction.

Mitigation Measure GWH-2: Operate Project in Compliance with SWRCB and DHS Policies

MPWMD shall operate the Proposed Project in compliance with the SWRCB's Anti-Degradation Policy (Resolution 68-16), and applicable DHS regulations regarding drinking water quality.

Monitoring: MPWMD is responsible for ensuring that this mitigation measure is implemented. MPWMD will conduct on-site monitoring during project operation.

Mitigation Measure GWH-3: Modify Project Operations as Required by Results of Monitoring

Groundwater conditions shall be tracked via the MPWMD's existing monthly monitoring program. In the event that any adverse impacts to groundwater conditions occur, MPWMD shall halt operations and consult with the RWQCB to determine appropriate operational changes.

Monitoring: MPWMD is responsible for ensuring that this mitigation measure is implemented. MPWMD will conduct on-site monitoring during project operation.

Mitigation Measure GWH-4: Operate Project in Compliance With NOAA Fisheries Recommendations and to Reduce Unlawful Diversions

MPWMD shall operate the Proposed Project in accordance with all of the bypass terms recommended by NOAA Fisheries in its 2002 report, *Instream Flow Needs for Steelhead in the Carmel River, Bypass Flow Recommendations for Water Supply Projects Using Carmel River Waters*. In addition, Cal-Am shall, to the maximum extent feasible, be required to utilize water that is available from the Seaside Basin due to the Proposed Project during the low-flow season from June 1 through November 30 to help reduce unlawful diversions from the Carmel River.

Monitoring: MPWMD is responsible for ensuring that this mitigation measure is implemented. MPWMD will conduct on-site monitoring during project operation.

Noise

Mitigation Measure NZ-1a: Prohibit Ancillary and Unnecessary Equipment During Nighttime Well Drilling Activities.

The project applicant shall ensure that the construction contractor prohibit the use of all ancillary and unnecessary equipment during nighttime hours. The only equipment that will be allowed to operate during nighttime activities would be the drilling and well construction equipment; cleanup and other activities will occur only during daytime activities.

Monitoring: MPWMD is responsible for ensuring that this mitigation measure is implemented. MPWMD will conduct on-site monitoring during construction.

Mitigation Measure NZ-1b: Employ Noise-Reducing Construction Practices to Meet Nighttime Standards.

The construction contractor will employ noise-reducing construction practices such that nighttime standards (Table 10-3) are not exceeded. Measures that will be used to limit noise include, but are not limited to:

- using noise-reducing enclosures around noise-generating equipment;
- constructing barriers between noise sources and noise-sensitive land uses or taking advantage of existing barrier features (terrain, structures) to block sound transmission; and
- enclosing equipment.

Monitoring: MPWMD is responsible for ensuring that this mitigation measure is implemented. MPWMD will conduct on-site monitoring during construction.

Mitigation Measure NZ-1c: Prepare a Noise Control Plan.

The construction contractor will prepare a detailed noise control plan based on the construction methods proposed. This plan will identify specific measurement that will be taken to ensure compliance with the noise limits specified above. The noise control plan will be reviewed and approved by City of Seaside staff before any noise-generating construction activity begins.

Monitoring: Prior to initiation of construction activities, MPWMD will ensure that this mitigation measure is implemented. MPWMD is responsible for ensuring compliance for the duration of the project.

Mitigation Measure NZ-1d: Disseminate Essential Information to Residences and Implement a Complaint/Response Tracking Program.

The construction contractor will notify residences within 500 feet of the construction areas of the construction schedule in writing prior to construction.

The construction contractor will designate a noise disturbance coordinator who will be responsible for responding to complaints regarding construction noise. The coordinator will determine the cause of the complaint and will ensure that reasonable measures are implemented to correct the problem. A contact telephone number for the noise disturbance coordinator will be conspicuously posted on construction site fences and will be included in the written notification of the construction schedule sent to nearby residents.

Monitoring: Prior to initiation of construction activities, MPWMD will ensure that this mitigation measure is implemented. MPWMD is responsible for ensuring compliance for the duration of the project.

Mitigation Measure NZ-2: Design Pump Stations to Meet Local Noise Standards.

MPWMD will design the new pump station and chemical/electrical building so that noise levels do not exceed applicable City of Seaside noise standards and ordinances. Prior to field acceptance, MPWMD will retain an acoustical consultant to measure noise levels from the operating facility. If project-generated noise exceeds the noise ordinance performance standards, additional noise attenuation measures will be implemented to meet the standards. The proposed facility will not receive final acceptance until the required noise standards are met. This measure will be made a condition of the final design review.

Monitoring: Prior to initiation of construction activities, MPWMD will ensure that this mitigation measure is implemented. MPWMD is responsible for ensuring compliance for the duration of the project.

Hazards and Hazardous Materials

Mitigation Measure HAZ-1: Implement MEC Safety Precautions during Grading and Construction Activities at the Project Site.

Because of the proposed well site's location, the following safety precautions are required for on-site activities. The requirements may be modified upon completion of the Munitions Response Remedial Investigation/Feasibility Study (MR RI/FS) process for the munitions response sites.

- All personnel accessing the proposed well site will be trained in MEC recognition. This safety training is provided by the U.S. Army at no cost to the trainee. Training may be scheduled by contacting Fort Ord BRAC Office, Lyle Shurtleff at 831-242-7919.
- If an item is discovered that is or could be MEC, it shall not be disturbed. The item shall be reported immediately to the Presidio of Monterey Police Department at 831-242-7851 so that appropriate U.S. military explosive ordnance disposal personnel can be dispatched to address such MEC as required under applicable law and regulations at the expense of the army.

- Ground disturbing activities, including perimeter fence installation, will be coordinated with USACE Unexploded Ordnance Safety Specialist so that appropriate construction-related precautions may be provided (Fisbeck pers. comm.). The USACE Pamphlet EP 75-1-2 entitled *Munitions and Explosives of Concern (MEC) Support During Hazardous, Toxic and Radioactive Waste (HTRW) and Construction Activities*, dated August 1, 2004, which can be found at <http://www.usace.army.mil/inet/usace-docs/eng-pamphlets/ep75-1-2/toc.htm> shall be followed by the USACE Safety Specialist to determine the type of construction oversight that will be needed based on the type of construction activities to be performed.
- Construction activities at the project site are subject to Monterey County Code, Ordinance 5012, Subsection 1 dated 2005, Title 16 “Environment,” Chapter 16.1 “Digging and Excavating on the Former Fort Ord,” which can be found at <http://municipalcodes.lexisnexis.com/codes/montereyco>. This ordinance prohibits excavation, digging, development, or ground disturbance unless an excavation permit is obtained and the permit requirements are followed.

Monitoring: MPWMD is responsible for ensuring that this mitigation measure is implemented. MPWMD will conduct on-site monitoring during construction.

Public Services and Utilities

Mitigation Measure PS-1: Coordinate Relocation and Interruptions of Service with Utility Providers during Construction

The construction contractor will contact Underground Service Alert (800/642-2444) at least 48 hours before excavation work begins in order to verify the nature and location of underground utilities. In addition, the contractor will notify and coordinate with public and private utility providers at least 48 hours before the commencement of work adjacent to any utility, unless the excavation permit specifies otherwise. In addition, the service provider will be notified in advance of all service interruptions and will be given sufficient time to notify customers. The timing of interruptions will be coordinated with the providers to ensure that the frequency and duration of interruptions are minimized.

Monitoring: MPWMD is responsible for ensuring that this mitigation measure is implemented. MPWMD will conduct on-site monitoring during construction.

Mitigation Measure PS-2: Protect All Existing Utilities Slated to Remain

The construction contractor will be responsible for ensuring protection of all utilities slated to remain. All buried lines will be tape-coated in accordance with the requirements of American Water Works Association C214. All new water services, fire services, and water mains will be cathodically protected, in accordance with contract documents. In addition, the contractor will be required to comply with State Department of Health Services criteria for the separation of water mains and sanitary sewers, as set forth in Section 64630, Title 22, of the

California Administrative Code. MPWMD will ensure this measure is included in the contract specifications.

Monitoring: MPWMD is responsible for ensuring that this mitigation measure is implemented. MPWMD will conduct on-site monitoring during construction.

Visual Resources

Mitigation Measure VIS-1: Incorporate Light-Reduction Measures into the Plan and Design of Exterior Lighting at Well Site.

Where lighting is required or proposed, MPWMD will incorporate the following light-reduction measures into the lighting design specifications to reduce light and glare. The lighting design will also meet minimum safety and security standards.

- Luminaires will be the minimum required for property security to minimize incidental light.
- Luminaires will be cutoff-type fixtures that cast low-angle illumination to minimize incidental spillover of light onto adjacent properties and open space. Fixtures that project light upward or horizontally will not be used.
- Luminaires will be focused only where needed (such as building entrances) and should not provide a general “wash” of light on building surfaces.
- Luminaires will be directed away from habitat and open space areas adjacent to the project site.
- Luminaires will provide good color rendering and natural light qualities. Low-pressure sodium and high-pressure sodium fixtures that are not color-corrected will not be used.
- Luminaire mountings will be downcast and the height of poles minimized to reduce potential for backscatter into the nighttime sky and incidental spillover of light onto adjacent properties and open space. Light poles will be no higher than 20 feet. Luminaire mountings will have nonglare finishes.

Monitoring: Prior to initiation of construction activities, MPWMD will ensure that this mitigation measure is implemented. MPWMD is responsible for ensuring compliance for the duration of the project.

Cumulative Impacts

Mitigation Measure Cume-1: Coordinate with Relevant Local Agencies to Develop and Implement a Phased Construction Plan to Reduce Cumulative Traffic, Air Quality, and Noise Impacts

MPWMD will contact local agencies that have projects planned in the same area (i.e., project sites within 1 mile or projects that affect the same roadways) and that have construction schedules that overlap with construction of the Proposed

Project. MPWMD (or their contractor) will coordinate with local agencies responsible for said projects to develop a phased construction plan that includes the following components.

- Evaluate roadways affected by construction activities and minimize roadway and traffic disturbance (e.g., lane closures and detours) and the number of construction vehicles using the roadways. This may involve scheduling some construction activities simultaneously or phasing.
- Prepare compatible traffic control plans for construction projects. If one traffic control plan cannot be prepared, the construction contractor for the Proposed Project and the relevant local agencies (or their construction contractors) will ensure that the traffic control plans for projects affecting the same roadways are compatible. The traffic control plan can be modeled after that required for the Proposed Project in Chapter 2.
- Phase construction activities so NO_x and PM10 emissions remain below MPUAPCD thresholds. For medium and large projects (defined as projects that involve construction on a 1-acre site or larger because there is a reasonable likelihood it could contribute to exceeding the MBUAPCD NO_x and PM10 emissions thresholds) that will be constructed during the same timeframe, MPWMD and the agencies will develop a phased construction plan so the cumulative NO_x emissions remain below 137 pounds per day and the cumulative PM10 emissions remain below 82 pounds per day (or less than 2.2 acres per day is disturbed). The phased construction plan will identify planned construction activities and equipment, anticipated emissions, and a schedule that can be used to estimate daily emissions. The phased construction plan will be reviewed and approved by the MPUAPCD. It will likely be necessary for proponents of other projects to implement NO_x -reducing construction practices, as well as dust reduction measures, to ensure NO_x and PM10 emissions are at acceptable levels. The dust reduction measures should include all feasible measures contained in Table 8-2 of MBUAPCD's CEQA Air Quality Guidelines (Getchell pers. comm.), which include the following.
 - Limit grading to 8.1 acres per day and grading and excavation to 2.2 acres per day.
 - Water graded / excavated areas at least twice daily. Frequency should be based on the type of operations, soil and wind exposure.
 - Prohibit all grading activities during periods of high wind (over 15 mph).
 - Apply chemical soil stabilizers on inactive construction areas (disturbed lands within construction projects that are unused for at least four consecutive days).
 - Apply nontoxic binders (e.g., latex acrylic copolymer) to exposed areas after cut and fill operations, and hydro-seed area.
 - Haul trucks shall maintain at least 2'0" of freeboard.
 - Cover all trucks hauling dirt, sand, or loose materials.

- Plant tree windbreaks on the windward perimeter of construction projects if adjacent to open land.
- Plant vegetative ground cover in disturbed areas as soon as possible.
- Cover inactive storage piles.
- Install wheel washers at the entrance to construction sites for all exiting trucks.
- Pave all roads at construction sites.

Monitoring: Prior to initiation of construction activities, MPWMD will ensure that this mitigation measure is implemented. MPWMD is responsible for ensuring compliance for the duration of the project.

Temporary Pipeline Analysis

Mitigation Measure WLD-1. Comply with U.S. Fish and Wildlife Service Biological Opinion Terms and Conditions. The U.S. Army will require that any contracts let to construct the proposed temporary pipeline include the U.S. Fish and Wildlife Service BO terms and conditions for Reasonable and Prudent Measures numbers 5, 6, and 7 (U.S. Fish and Wildlife Service 2005, pages 63–65).

Monitoring: Prior to initiation of construction activities, Cal-Am will ensure that this mitigation measure is implemented. Cal-Am is responsible for ensuring compliance for the duration of the project.

Mitigation Measure WLD-2: Remove Trees and Shrubs during the Nonbreeding Season for Most Birds (September 1 To February 15)

The placement and removal of the temporary pipeline may result in the trimming of trees and shrubs that provide suitable nesting habitat for migratory birds. To avoid the loss of active migratory bird nests, tree and shrub removal, if necessary, will be conducted only during the nonbreeding season for migratory birds (generally September 1 to February 15). Removing woody vegetation during the nonbreeding season will ensure that active nests will not be destroyed by removal of trees supporting or adjacent to active nests.

If shrub and tree trimming cannot be accomplished before the breeding season, a qualified wildlife biologist will conduct focused nest surveys for active nests of migratory bird species. If active nests are found in the project area, and if construction activities must occur during the nesting period, an appropriate “no-disturbance” buffer around the nest sites will be implemented until the young have fledged (as determined by a qualified biologist).

Monitoring: Prior to initiation of construction activities, Cal-Am will ensure that this mitigation measure is implemented. Cal-Am is responsible for ensuring compliance for the duration of the project.

Mitigation Measure CUL-1: Stop Work if Buried Cultural Deposits Are Encountered during Construction Activities

If buried cultural resources such as chipped or ground stone, quantities of bone or shell material, or historic debris or building foundations are inadvertently discovered during ground-disturbing activities, work will be stopped within a 100-foot radius of the find until a qualified archaeologist can assess the significance of the find. If, after evaluation by a qualified archaeologist, an archaeological site or other find is identified as meeting the criteria for inclusion in the NRHP or the CRHR, Cal-Am will retain a qualified archaeologist to develop and implement an adequate program for investigation, avoidance if feasible, and data recovery for the site, with Native American consultation, if appropriate.

If human skeletal remains are inadvertently encountered during construction of the temporary pipeline, the contractor will contact the Monterey County Coroner immediately. If the county coroner determines that the remains are Native American, the coroner will contact the NAHC, as required by Section 7050.5[c] of the California Health and Safety Code, and the County Coordinator of Indian Affairs. A qualified archaeologist will also be contacted immediately.

Monitoring: Cal-Am is responsible for ensuring that this mitigation measure is implemented. Cal-Am will conduct on-site monitoring during construction.

Mitigation Measure HAZ-1: Provide MEC Training to Construction Workers.

All construction workers that will enter the project site will receive training from qualified personnel on the identification and avoidance of MEC prior to beginning work.

Monitoring: Cal-Am is responsible for ensuring that this mitigation measure is implemented. Cal-Am will conduct on-site monitoring during construction.

EXHIBIT 16-A

Backflush Basin Expansion

ATTACHMENT 5

**BID DRAWINGS FOR SANTA MARGARITA ASR FACILITY SITE EXPANSION,
PREPARED BY MAC DESIGN ASSOCIATES AND PUEBLO WATER RESOURCES,
DATED MAY 25, 2018**

EXHIBIT 16-A

Backflush Basin Expansion

This page is intentionally blank.

GENERAL NOTES

- ALL STATIONING & DISTANCES INDICATED ON THE DRAWINGS ARE BASED ON HORIZONTAL MEASUREMENTS IN FEET.
- THE CONTRACTOR SHALL NOTIFY THE MPWMD AND CALIFORNIA AMERICAN WATER REPRESENTATIVES AT LEAST 2 WORKING DAYS IN ADVANCE OF ANY WORK WHICH WILL REQUIRE THE INSPECTION SERVICES.
- "OWNER" SHALL MEAN THE MPWMD. "UTILITY" SHALL MEAN CALIFORNIA AMERICAN WATER COMPANY. "ENGINEER" IS THE MPWMD PROJECT ENGINEER, PUEBLO WATER RESOURCES.
- AT LEAST 2 WORKING DAYS PRIOR TO ANY EXCAVATION WORK THE CONTRACTOR SHALL CALL UNDERGROUND SERVICE ALERT AT 1-800-642-2444 FOR LOCATING AND MARKING UNDERGROUND UTILITIES IN THE AREAS OF WORK.
- THE EXISTING UTILITIES SHOWN AND INDICATED ON THE DRAWINGS ARE APPROXIMATE AND FOR GENERAL INFORMATION ONLY, AND ARE BASED ON AVAILABLE UTILITY INFORMATION PROVIDED BY THE UTILITY OWNER AND SELECTED FIELD LOCATING. THE CONTRACTOR SHALL ASSUME FULL RESPONSIBILITY FOR VERIFICATION OF EXISTING UNDERGROUND UTILITIES, WHETHER INDICATED OR NOT ON THE DRAWINGS, PRIOR TO ANY CONSTRUCTION ACTIVITY. THE CONTRACTOR SHALL PROTECT ALL EXISTING OR NEWLY PLACED UTILITY STRUCTURES AND LINES FROM DAMAGE OR DISRUPTION OF SERVICE DURING CONSTRUCTION. THE CONTRACTOR SHALL PROVIDE NECESSARY TEMPORARY UTILITY SERVICES AND SHALL RESTORE PERMANENT UTILITY SERVICES DISRUPTED BY CONSTRUCTION ACTIVITY.
- THE CONTRACTOR SHALL EXPOSE ALL EXISTING UTILITY LINES AT LEAST ONE WORKING DAY AHEAD OF PIPE LAYING OPERATION TO VERIFY LOCATION AND DEPTH OF EXISTING UTILITIES. ANY CONFLICTS WILL BE RESOLVED BY THE MPWMD REPRESENTATIVE PRIOR TO PIPE INSTALLATION. IF ANY UNDERGROUND UTILITIES ARE DISCOVERED, THE CONTRACTOR SHALL SUBMIT ACCURATE STAMPED, SIGNED AND DATED DOCUMENTS DESCRIBING THE QUANTITY, SIZE, LOCATION, DEPTH, AND TYPE OF MATERIAL OF FOUND BURIED UTILITIES.
- THE CONTRACTOR SHALL BE RESPONSIBLE FOR MONITORING FOR THE PRESENCE OF CONTAMINATED SOIL AND/OR GROUNDWATER DURING THE COURSE OF THE WORK. THE CONTRACTOR SHALL IMMEDIATELY NOTIFY THE MPWMD REPRESENTATIVE IF ANY SUSPECT MATERIALS ARE ENCOUNTERED. CONTACT SHALL BE MADE IMMEDIATELY BY TELEPHONE, WITH WRITTEN NOTIFICATION WITHIN 3 WORKING DAYS.
- ALL TRENCHING OPERATIONS SHALL BE IN ACCORDANCE WITH THE REQUIREMENTS OF TITLE 8 (CAL/OSHA).
- THE CONTRACTOR SHALL BE RESPONSIBLE FOR ANY DAMAGE ON OR OFF THE PROJECT SITE AS A RESULT OF CONSTRUCTION ACTIVITIES INCLUDING THE LACK OF DUST CONTROL AND TRAFFIC CONTROL.
- UPON COMPLETION OF THE WORK, THE CONTRACTOR SHALL CERTIFY THAT ALL WORK WAS PERFORMED IN ACCORDANCE WITH THE REQUIREMENTS OF THE CONTRACT DOCUMENTS, VARIATIONS SHALL BE DECLARED AND PRESENTED TO THE MPWMD IN WRITING UPON COMPLETION OF CONSTRUCTION, IN THE FORM OF MARKED UP PLANS SHOWING ALL CHANGES.
- THE ENGINEER AND/OR THE MPWMD REPRESENTATIVE WILL NOT DIRECTLY CONTROL THE PHYSICAL ACTIVITIES OF THE CONTRACTOR OR ANY SUBCONTRACTORS. CONTRACTOR WILL BE SOLELY AND COMPLETELY RESPONSIBLE FOR WORKING CONDITIONS ON THE JOB SITE, INCLUDING SAFETY OF ALL PERSONS AND PROPERTY DURING PERFORMANCE OF THE WORK. THIS REQUIREMENT WILL APPLY CONTINUOUSLY AND NOT BE LIMITED TO NORMAL WORKING HOURS.
- THE CONTRACTOR SHALL VERIFY WORK IN THE FIELD AND SHALL SATISFY HIMSELF AS TO THE ACCURACY BETWEEN WORK SET FORTH ON THESE PLANS AND THE WORK REQUIRED IN THE FIELD. ANY DISCREPANCIES SHALL BE BROUGHT TO THE ATTENTION OF THE MPWMD REPRESENTATIVE PRIOR TO THE START OF CONSTRUCTION.
- THE CONTRACTOR SHALL SUBMIT A TRAFFIC CONTROL PLAN TO THE PROJECT ENGINEER FOR APPROVAL AND SHALL COORDINATE ALL WORK TO ALLOW VEHICLE ACCESS TO RESIDENCES AND/OR BUSINESSES NEAR THE PROJECT AREA. EXCEPT WHEN A LANE CLOSURE IS IN EFFECT IN ACCORDANCE WITH THE CONTRACTOR'S APPROVED TRAFFIC CONTROL PLAN, NO VEHICLES, EQUIPMENT OR MACHINERY ARE ALLOWED TO PARK ON THE SHOULDER OF GENERAL JIM MOORE BOULEVARD AT ANY TIME.
- ANY AREAS DISTURBED BY THE CONTRACTOR'S OPERATIONS SHALL BE RESTORED TO ORIGINAL CONDITIONS AND HYDROSEEDED SO AS TO RESTORE NATURAL GROWTH, THIS INCLUDES ALL CUT OR FILL SLOPES. HYDROSEED MIX BE NATIVE MIX IN ACCORDANCE WITH REQUIREMENTS ON THE FORMER FORT ORD. A LAYER OF CRETIPEF WEED FREE MULCH, WEED FREE RICE, STERILE BARLEY STRAW, OR OTHER SIMILAR FUNCTIONING PRODUCT SHALL BE INSTALLED FOR EROSION CONTROL. CLEARED DELETERIOUS MATERIAL MUST BE WOODCHIPPED AND USED ON THE SITE AS MULCH.
- THE CONTRACTOR IS RESPONSIBLE FOR OBTAINING A TEMPORARY CONSTRUCTION WATER APPLICATION FOR WATER USE AND METERING FROM MARINA COAST WATER DISTRICT PHONE NUMBER IS (831) 384-6131.
- CONSTRUCTION SHALL COMPLY WITH THE 2006 STANDARD PLANS AND SPECIFICATIONS OF THE CALIFORNIA DEPARTMENT OF TRANSPORTATION, STATE OF CALIFORNIA, AND THE CITY OF SEASIDE STANDARD DETAILS AS NOTED ON THE CONSTRUCTION PLANS. THE CONTRACTOR SHALL BE RESPONSIBLE FOR OBTAINING COPIES OF SAID DOCUMENTS AND SHALL HAVE THEM AVAILABLE ON THE PROJECT SITE AT ALL TIMES DURING CONSTRUCTION.
- WATER LINES, VALVES, AND WATER APPURTENANCES SHALL CONFORM TO THE 2017 STANDARD SPECIFICATIONS AND STANDARD PLANS OF THE CALIFORNIA AMERICAN WATER COMPANY.
- ALL CONCRETE, REGARDLESS OF USE, SHALL HAVE A MINIMUM COMPRESSIVE STRENGTH OF 3,000 PSI.
- ALL EARTHWORK AND FOUNDATION CONSTRUCTION SHALL BE PERFORMED IN ACCORDANCE WITH THE REQUIREMENTS AND SPECIFICATIONS OF THE GEOTECHNICAL INVESTIGATION. CONTACT THE GEOTECHNICAL ENGINEER AT LEAST 48 HOURS PRIOR TO REQUESTING ON-SITE OBSERVATION OR TESTING SERVICES.
- THE CONTRACTOR'S WORK SHALL CONFORM TO THE CITY OF SEASIDE'S ORDINANCE REGARDING MUNITIONS & EXPLOSIVES OF CONCERN (MEC).
- ELECTRICAL AND/OR COMMUNICATIONS CONDUITS SHALL BE NONMETALLIC SCHEDULE 40 P.V.C. PLASTIC RATED 90° C WITH GLUE ON P.V.C. COUPLINGS AND FACTORY MADE ELBOWS AND SWEEPS: CARLON "PLUS40".
- "OWNER" IS THE MONTEREY PENINSULA WATER MANAGEMENT DISTRICT (MPWMD), 5 HARRIS COURT BUILDING G, MONTEREY, CA. 94940. MPWMD SHALL REFER TO MPWMD OR MPWMD REPRESENTATIVE.

GENERAL WATER FACILITIES NOTES

CALIFORNIA-AMERICAN WATER COMPANY STANDARD DRAWINGS NO. A, B, C, D)

APPLICABLE TO CONSTRUCTION OF WATER MAIN AND APPURTENANCES FOR MONTEREY, MONTARA FELTON AND EAST PALO ALTO SERVICE TERRITORIES.

- DEFINITIONS: IN THE FOLLOWING NOTES, UTILITY SHALL MEAN CALIFORNIA-AMERICAN WATER COMPANY, 511 FOREST LODGE ROAD, SUITE 100, MONTEREY, CA. 93950 AND INSTALLER SHALL MEAN ANY DEVELOPER, CONTRACTOR PROPERTY OWNER, FIRM OR PERSON WHO HAS BEEN DULY AUTHORIZED BY MPWMD AND CALIFORNIA-AMERICAN WATER COMPANY TO PERFORM WORK ON THE WATER SYSTEMS AND FACILITIES OWNED AND/OR OPERATED BY CALIFORNIA-AMERICAN COMPANY.
- PROJECT CONTACT PERSON: FOR MATTERS RELATED TO WORK TO BE PERFORMED BY INSTALLER, PLEASE CONTACT MPWMD, 5 HARRIS COURT, BLDG. "G", ATTN:MAUREEN HAMILTON, MPWMD AT MHamilton@mpwmd.net .
- INSTALLER REPRESENTATIVE. INSTALLER SHALL ASSIGN AND PROVIDE UTILITY WITH THE NAME AND CONTACT INFORMATION OF A REPRESENTATIVE (JOB FOREMAN) AT THE JOB SITE WHERE THE WORK WILL BE PERFORMED ON UTILITY FACILITIES. INSTALLER'S REPRESENTATIVE IS REQUIRED TO ATTEND ANY PRE-CONSTRUCTION WALK-THROUGH MEETINGS. INSTALLER REPRESENTATIVE IS REQUIRED TO BE ON THE JOBSITE DURING ALL PHASES OF WORK, INCLUDING INSPECTIONS, AND INSTALLER SHALL NOT REPLACE THE REPRESENTATIVE WITHOUT PRIOR APPROVAL FROM UTILITY.
- STATE AND COUNTY ROAD ENCRoACHMENT PERMITS. ANY WORK WITHIN A STATE RIGHT-OF-WAY SHALL COMPLY WITH THE REQUIREMENTS OF THE STATE DEPARTMENT OF TRANSPORTATION (CALTRANS), INCLUDING ENCRoACHMENT PERMITS. WORK WITHIN A COUNTY RIGHT-OF-WAY SHALL COMPLY WITH COUNTY REQUIREMENTS, INCLUDING ENCRoACHMENT PERMITS. IT SHALL BE INSTALLER'S RESPONSIBILITY TO BE THOROUGHLY FAMILIAR WITH THE STATE AND/OR COUNTY STANDARDS OF WORK REQUIRED AND INCLUDE THE FULL COST OF COMPLIANCE INCLUDING TRAFFIC CONTROL, PERMITS, TRENCH FEES, ETC., IN THE RESPECTIVE BIT ITEMS.

UNAUTHORIZED CHANGES & USES CAUTION:
The engineer preparing these plans will not be responsible for, or liable for, unauthorized changes to or uses of these plans. All changes to the plans must be in writing and must be approved by the preparer of these plans.

GENERAL WATER FACILITIES NOTES (CONT.)

- OTHER PERMITS. INSTALLER OR HIS REPRESENTATIVE SHALL BE REQUIRED TO VERIFY THE REQUIRED PERMITS FOR THE WORK TO BE PERFORMED AND OBTAIN AND COMPLY WITH ALL NECESSARY PERMITS FOR CONSTRUCTION OF THE WATER SYSTEM, INCLUDING ENCRoACHMENT PERMITS, DIGGING AND EXCAVATION ON FORMER FORT ORD PERMIT. INSTALLER IS RESPONSIBLE FOR NOTIFICATION TO MPWMD AND ANY JURISDICTIONAL AGENCIES BEFORE COMMENCEMENT OF WORK.
- IDENTIFICATION OF BURIED UTILITIES. BEFORE ANY WORK ON UNDERGROUND FACILITIES, INSTALLER SHALL CONTACT UNDERGROUND SERVICE ALERT (USA) OR IDENTIFYING ANY BURIED UTILITIES NEAR THE WORK AREA. USA (PHONE 1-800-642-2444) MUST BE GIVEN A 48 HOUR ADVANCE NOTICE. MPWMD IS ONLY RESPONSIBLE FOR MARKING THOSE WATER FACILITIES OWNED BY MPWMD AND SHALL NOT BE RESPONSIBLE FOR MARKING NEW FACILITIES UNTIL MPWMD ACCEPTS OWNERSHIP. ANY CALLS TO THE MPWMD REGARDING SUCH FACILITIES WILL BE FORWARDED TO THE INSTALLER. ANY DAMAGES TO WATER FACILITIES TO BE OWNED BY MPWMD MUST BE REPORTED TO MPWMD IMMEDIATELY AND MPWMD MUST BE ALLOWED TO INSPECT THE APPROVED REPAIRS OR REPLACEMENTS.
- WATER SHUTDOWN NOTICES. INSTALLER SHALL NOTIFY UTILITY OR ASSOCIATED COMPANIES 48 HOURS BEFORE COMMENCING CONSTRUCTION AND FOR NOTIFICATION OF WATER SYSTEM SHUT OFF REQUESTS. INSTALLER MUST ENSURE THAT SHUT DOWN TIME WILL NOT EXCEED FOUR (4) HOURS WITHOUT PRIOR UTILITY AUTHORIZATION.
- INSPECTION NOTICES. WHEN APPLICABLE, INSTALLER SHALL GIVE UTILITY AND CITY OF SEASIDE INSPECTORS 48 HOURS NOTICE (MINIMUM) BEFORE SCHEDULING ANY MEETING OR STARTING CONSTRUCTION, AND 24 HOURS NOTICE (MINIMUM) FOR INSPECTION.
- VERIFICATION OF DATA AND INFORMATION PROVIDED BY UTILITY. NOTICE IS HEREBY GIVEN TO THE INSTALLER THAT UTILITY HAS MADE ALL REASONABLE EFFORTS TO IDENTIFY THE TYPES, LOCATIONS, SIZES AND DEPTHS OF EXISTING OR PLANNED UNDERGROUND OR ABOVEGROUND UTILITIES, STRUCTURES, ROADS, PIPELINES, HARD ROCK, STRATA, TOPOGRAPHY, ETC. SUCH ITEMS, WHEN DEPICTED ON THE PLANS, HAVE BEEN OBTAINED FROM SOURCES OF VARYING RELIABILITY. THEREFORE, UTILITY AND ASSOCIATED COMPANIES CANNOT ASSUME RESPONSIBILITY FOR THE COMPLETENESS OR ACCURACY OF SAID INFORMATION. INSTALLER SHALL BE RESPONSIBLE FOR VERIFYING THE LOCATION OF ALL EXISTING FACILITIES BY POT-HOLING ALL WATER LINE CONNECTION POINTS TO CONFIRM SIZE, DEPTH AND MATERIAL TYPE OF EXISTING FACILITIES. IN CASE OF CONFLICT/S, INSTALLER SHALL BRING THE MATTER TO THE ATTENTION OF UTILITY FOR RESOLUTION BEFORE CONTINUING WORK.
- SURVEYING AND LOCATING. INSTALLER IS RESPONSIBLE FOR ALL REQUIRED SURVEYING AND STAKING, SHOWING THE LOCATION AND GRADES FOR INSTALLING THE WATER SYSTEM. INSTALLER IS RESPONSIBLE FOR PROTECTING AND MAINTAINING ALL SURVEY MONUMENTS AND STAKING WHETHER EXISTING OR DISCOVERED DURING CONSTRUCTION.
- JOBSITE SAFETY. INSTALLER IS SOLELY RESPONSIBLE FOR ANY CURRENTLY APPLICABLE SAFETY LAW OF ANY JURISDICTIONAL AGENCY. INSTALLER IS ALSO RESPONSIBLE FOR PROJECT SITE SAFETY AND FOR PUBLIC SAFETY INCLUDING TRAFFIC CONTROL, 24-HOURS PER DAY FOR ALL DAYS FROM THE NOTICE TO PROCEED THROUGH THE NOTICE OF COMPLETION.
- MATERIAL OF CONSTRUCTION. INSTALLER SHALL PROVIDE AND INSTALL ALL MATERIALS AND INSULATION OF THE WATER DISTRIBUTION SYSTEM IN ACCORDANCE WITH THE STANDARDS AND SPECIFICATIONS OF MPWMD AND CALIFORNIA-AMERICAN WATER COMPANY, WHICH ARE INCORPORATED HEREIN BY REFERENCE, UNLESS OTHERWISE NOTED ON THESE PLANS. MPWMD HAS THE FINAL DECISION ON ALL MATERIALS, INCLUDING BACKFILL, PIPE, FITTINGS, AND VALVES, THAT WILL BE USED FOR PLACEMENT OF ALL WATER FACILITIES INCLUDING ANY NEW WATER MAIN.
- WORK COORDINATION. INSTALLER IS RESPONSIBLE FOR COORDINATING THEIR WORK WITH ALL OTHER CONTRACTORS TO AVOID ANY CONFLICTS.
- PIPE AND FITTINGS. UNLESS SURROUNDING GROUND CONDITIONS DICTATE OTHERWISE, ALL HEADER PIPES FROM MAIN TO SERVICE METER SHALL BE 2" PVC, SCHEDULE 80, AND FROM METER TO SERVICE SHALL BE 1" OR 2" TYPE K COPPER. ALL STANDARD WATER MAINS LARGER THAN 12-INCHES SHALL BE CLASS 250, MORTAR LINED, BIT COATED AND POLYWRAPPED DUCTILE IRON. PIPING 12-INCH DIAMETER AND SMALLER SHALL BE AWWA C-900 CLASS 150 OR 200 PVC, UNLESS OTHERWISE NOTED (CLASS 200 PIPE IS REQUIRED WHEN WATER MAIN IS NEAR SEWERS). ALL FITTINGS SHALL BE DUCTILE IRON WITH CEMENT LINED INSIDE AND BITUMINOUS COATED OUTSIDE, WHICH SHALL BE PAINTED WITH POLYGLUE #14 MASTIC. INSTALLER SHALL PROVIDE PIPE AND FITTING MATERIALS SUBMITTAL TO MPWMD FOR APPROVAL BEFORE BEGINNING WORK.
- FLANGED FITTINGS. ALL FLANGED FITTINGS SHALL BE BOLTED TOGETHER WITH ZINC COATED STEEL NUTS AND BOLTS, GRADE 5 OR BETTER.
- MECHANICAL JOINTS. USE EBAA MECHANICAL JOINT MEGA-LUGS ON ALL MECHANICAL JOINT FITTINGS.
- SEPARATION DISTANCE FROM SEWER LINES AND SOURCES OF CONTAMINATION. WATER MAINS SHALL BE LAID IN SEPARATE TRENCHES AS FAR AS POSSIBLE FROM NEARBY SEWER AND STORM DRAIN LINES, C-900 CLASS 200 PVC PIPE OR CLASS 50 DUCTILE IRON PIPE SHALL BE USED (CLASS OR PRESSURE RATING TO BE DETERMINED OR APPROVED BY UTILITY). PLACEMENT OF WATER NEAR OTHER SOURCES OF HYDROCARBON RELATED FACILITIES SHOULD REQUIRE SPECIAL APPROVAL FROM UTILITY. INSTALLER TO IMMEDIATELY INFORM THE UTILITY ENGINEER WHEN INSUFFICIENT SEPARATION CONDITIONS OCCUR (LESS THAN 10- FEET HORIZONTAL OR 1-FOOT VERTICAL).
- UNDERGROUND PIPE IDENTIFIER. ALL INSTALLATION OF MAINS AND SERVICES SHALL HAVE GREEN COATED #10 GA. STANDARD COPPER WIRE FOR LOCATING.
- HOT TAPS. ALL TAPPING SLEEVES TO BE MECHANICAL JOINT TYPE OR ALL STAINLESS STEEL CIRCUMFERENCE SEAL TYPE WITH STAINLESS STEEL FLANGE, BOLTS AND NUTS.
- VALVES. UNLESS OTHERWISE NOTED OR DIRECTED BY UTILITY, INSTALLER SHALL INSTALL GATE VALVES (AWWA C-509) FOR WATER MAINS 12-INCHES OR SMALLER, AND INSTALL BUTTERFLY VALVES (AWWA C504) FOR MAINS LARGER THAN 12-INCHES. ALL VALVES SHALL BE FLANGED TO FITTINGS (CROSS, TEE, ETC.) EXCEPT WHERE MAINS ARE 4- FEET BEHIND SIDEWALK WITH TEES UNDER CORNER RADIUS IN WHICH CASE THE VALVE SHALL BE PLACED IN LINE BEYOND THE RADIUS AND RESTRAINED. GATE VALVES SHALL BE RESILIENT WEDGE, EPOXY COATED WITH S.S. BOLTS. VALVE STEMS SHALL BE PROVIDED FOR VALVES WITH A COVER OF 4- FEET OR GREATER. UNDERGROUND VALVES SHALL HAVE 8" DIAMETER (MINIMUM) VALVE BOX RISER, GRADE VALVE AND METAL LID MARKED "WATER", AS SHOWN ON UTILITY STANDARD DRAWINGS.
- NOT USED
- NOT USED
- CONCRETE THRUST BLOCKS. THRUST BLOCKS SHALL BE INSTALLED WHERE PIPE DEFLECTIONS EXCEED 4 DEGREES PER COUPLING/FITTINGS, AS SPECIFIED BY PIPE MANUFACTURER. USE EBAA MECHANICAL JOINT MEGA-LUGS ON ALL MECHANICAL JOINT FITTINGS. USE EBAA SERIES 1600 PIPE RESTRAINTS IN LIEU OF CONC. THRUST BLOCKS. UTILITY ENGINEER TO ADVISE INSTALLER OF REQUIRED LENGTH OF PIPE TO BE RESTRAINED. CONCRETE THRUST BLOCKS TO BE USED IF RESTRAINTS CANNOT BE UTILIZED.
- TRENCH DEPTH AND COVER. TRENCH DEPTH SHALL BE SUFFICIENT TO ALLOW TOP OF WATER MAINS 12-INCHES OR LESS TO HAVE A MINIMUM OF 36-INCHES OF COVER UNLESS OTHERWISE DIRECTED BY UTILITY ENGINEER. WATER MAINS OVER 12-INCHES SHALL HAVE A MINIMUM OF 42-INCHES OF COVER.
- INSPECTION BEFORE BACKFILLING. ALL WATER FACILITIES, INCLUDING MAINS, FITTINGS, VALVES AND SERVICES SHALL BE INSPECTED AND APPROVED BY MPWMD BEFORE BACKFILLING.
- BACKFILL SOIL COMPACTION TESTING. INSTALLER IS RESPONSIBLE FOR SECURING, COMPENSATING AND MONITORING OF; A STATE CERTIFIED INDEPENDENT SOILS TESTING SERVICE TO PROVIDE COMPACTION TESTING OF ALL BACKFILL WORK. COMPACTION TESTS DOCUMENTING COMPLIANCE WITH MINIMUM COMPACTION REQUIREMENTS WILL BE TAKEN AT 50 FOOT INTERVALS OR PER THE MINIMUM COUNTY REQUIREMENTS, WHICHEVER IS GREATER. ALL TESTING REPORTS SHALL BE SUBMITTED TO UTILITY FOR REVIEW AND APPROVAL AS SOON AS AVAILABLE. TESTING RESULTS FROM A CERTIFIED COUNTY OR CITY REPRESENTATIVE IS PERMITTED WHERE JURISDICTIONAL REQUIREMENTS PROVIDE SUCH COMPACTION TESTING.
- DISINFECTIONS AND FLUSHING. INSTALLER SHALL PERFORM DISINFECTIONS AND FLUSHING OF NEW WATER SYSTEM/S IN ACCORDANCE WITH CAL-AM STANDARDS AND AWWA C651-14. WITH REGARDS TO THE DISPOSAL OF THE FLUSH WATER, INSTALLER SHALL BE REQUIRED TO COMPLY WITH MPWMD, COUNTY AND STATE NPDES DISCHARGE PERMIT REQUIREMENTS AND SHALL PROVIDE NECESSARY DOCUMENTATION ENSURING COMPLIANCE WHERE APPLICABLE.
- INSPECTION BEFORE ACTIVATION. ALL WATER FACILITIES, INCLUDING MAINS, FITTINGS, VALVES AND SERVICES SHALL BE INSPECTED AND APPROVED BY MPWMD BEFORE ACTIVATION. INSTALLER SHALL PROVIDE HYDROSTATIC TEST TO BE WITNESSED BY MPWMD REPRESENTATIVE PER UTILITY STANDARDS. UTILITY SHALL COLLECT SAMPLES FOR BACTERIOLOGICAL TESTING. NEW SADDLES AND SERVICES SHALL BE INSTALLED PRIOR TO BACTERIOLOGICAL AND PRESSURE TESTING OF MAIN.
- AS-BUILT DRAWINGS. INSTALLER SHALL SUBMIT AS-BUILT (RECORD) DRAWINGS OF THE WATER SYSTEM, OR MODIFICATION INSTALLED BY THE INSTALLER. THE AS-BUILT DRAWINGS MUST BE SUBMITTED TO THE MPWMD WITHIN 30 DAYS OF COMPLETION OF CONSTRUCTION, RETENTIONS SHALL BE HELD UNTIL AS-BUILT APPROVAL BY MPWMD.
- WARRANTY. WARRANTY OF NEW FACILITIES TO BE CONVEYED TO MPWMD SHALL BE FOR A MINIMUM PERIOD OF ONE YEAR FROM DATE OF COMMENCEMENT (OR FINAL ACCEPTANCE).
- RETURNING PROPERTY TO ORIGINAL CONDITION. INSTALLER SHALL PHOTOGRAPH OR VIDEOTAPE JOB SITE AREA TO DOCUMENT EXISTING CONDITIONS BEFORE BEGINNING WORK TO MINIMIZE UNDUE CLAIMS. INSTALLER IS RESPONSIBLE TO RETURN ALL PROPERTY TO ORIGINAL OR BETTER CONDITION, INCLUDING TRAFFIC MARKINGS. ALL CLAIMS SHALL BE BORNE AND RESOLVED BY INSTALLER OR MPWMD SHALL ADDRESS SAID CLAIM AND MAY DEDUCT ANY COSTS FRO FINAL PAYMENT/RETENTION. A COPY OF THE CLAIM DOCUMENTS SHALL BE SUBMITTED TO MPWMD WITHIN 48 HOURS AFTER RECEIVING ANY SUCH CLAIMS.

THE CONTRACTOR'S WORK SHALL CONFORM TO THE CITY OF SEASIDE'S ORDINANCE REGARDING MUNITIONS & EXPLOSIVES OF CONCERN (MEC).



DATE SIGNED

GRADING AND PAVING NOTES

- ALL WORK SHALL BE IN CONFORMANCE WITH THE FOLLOWING:
 - PROJECT PLANS AND SPECIFICATIONS
 - STANDARD SPECIFICATIONS AND STANDARD DETAILS, LATEST EDITION OF THE CITY OF SEASIDE.
 - APPLICABLE SECTIONS OF THE CALTRANS STANDARD SPECIFICATIONS, LATEST EDITION.
 - APPLICABLE SWPPP, NOI, AND NPDES REQUIREMENTS FOR THE PROJECT.
 - FORT ORD REUSE AUTHORITY RIGHT OF ENTRY, CITY OF SEASIDE DIGGING AND EXCAVATING ON THE FORMER FORT ORD PERMIT
 - AQUIFER STORAGE AND RECOVERY MITIGATION MONITORING PLAN
 - CONTRACTOR SHALL NOTIFY MPWMD, CAL-AM, & THE CITY OF SEASIDE AT LEAST TWO (2) WORKING DAYS BEFORE STARTING GRADING WORK.
 - WORK SHALL CONSIST OF ALL EARTHWORK RELATED TO THE SITE: ALL CLEARING, GRUBBING, STRIPPING, ROUGH GRADING, PREPARATION OF FOUNDATION AND MATERIALS FOR RECEIVING FILLS, EXCAVATION, IMPORT AND/OR EXPORT OF FILL, PROCESSING, PLACEMENT AND COMPACTION OF FILL MATERIALS, PLACEMENT OF SUBSURFACE DRAINS, PLACEMENT OF AGGREGATE BASE MATERIAL ASPHALT CONCRETE (AC) AND/OR PORTLAND CEMENT CONCRETE (PCC) PAVING, AND ALL SUBSIDIARY WORK NECESSARY TO COMPLETE THE GRADING AND PAVING TO CONFORM TO THE LINES, GRADES AND SLOPES, AS SHOWN ON THESE PLANS.
 - SITE CONDITIONS: THE CONTRACTOR SHALL VISIT THE SITE, EXAMINE AND NOTE ALL CONDITIONS AS TO THE CHARACTER AND EXTENT OF WORK INVOLVED.
 - CONTRACTOR SHALL OBTAIN ALL NECESSARY PERMITS OR CERTIFICATES AS REQUIRED BY THE CITY.
 - ALL EARTHWORK SHALL BE CONSTRUCTED PER THE GRADING SPECIFICATIONS IN THE GEOTECHNICAL REPORT. ALL SOIL SHALL BE COMPACTED TO A MINIMUM OF 90% RELATIVE COMPACTION, AS REQUIRED BY THE ASTM TEST DESIGNATIONS D1557, D1556 AND D2992, EXCEPT THE PAVEMENT SUB-GRADE. THE UPPER LAYER OF SUBGRADE SHALL BE COMPACTED TO 95% RELATIVE COMPACTION, THE EXACT DEPTH SHALL BE DETERMINED BY THE GEOTECHNICAL ENGINEER AND/OR AS SHOWN ON THESE PLANS.
 - BACKFILL FOR UNDERGROUND UTILITIES PLACED ON THE SITE SHALL CONSIST OF CLEAN SAND MATERIAL (MINIMUM S.E. = 30) TO A MINIMUM OF 12 INCHES OVER THE CONDUIT, UNLESS SHOWN OTHERWISE ON THE PLAN. BACKFILL FOR UNDERGROUND UTILITIES PLACED IN EXISTING STREETS SHALL CONSIST OF CLEAN, IMPORTED SAND MATERIAL (MINIMUM S.E. = 30) AND MEETING THE REQUIREMENTS OF SECTION 19-306C(1) FOR THE FULL TRENCH DEPTH TO THE PAVEMENT SUBGRADE, UNLESS SHOWN OTHERWISE ON THE PLAN. A SAMPLE SHALL BE SUBMITTED FOUR (4) DAYS BEFORE INTENDED USE, FOR REVIEW BY THE ENGINEER. BACKFILL WITHIN THE UTILITY TRENCHES SHALL BE COMPACTED TO A MINIMUM RELATIVE COMPACTION OF 90% OR 95% DEPENDING UPON THE LOCATION AND BASED UPON THE ASTM TEST DESIGNATIONS D1557, D1556 AND D2992.
 - AT ALL TIMES DURING CONSTRUCTION AND UNTIL FINAL COMPLETION, THE CONTRACTOR, WHEN HE OR HIS SUBCONTRACTORS ARE OPERATING EQUIPMENT ON THE SITE, SHALL PREVENT THE FORMATION OF AN AIRBORNE DUST NUISANCE BY WATERING AND/OR TREATING THE SITE OF THE WORK IN SUCH A MANNER THAT WILL CONFINE DUST PARTICLES TO THE IMMEDIATE SURFACE OF THE WORK. THE CONTRACTOR WILL BE RESPONSIBLE FOR ANY DAMAGE DONE BY THE DUST FROM HIS OR HER SUBCONTRACTOR'S ACTIVITIES IN PERFORMING THE WORK UNDER THIS CONTRACT. THE PRICES FOR THE VARIOUS ITEMS OF WORK SHALL COVER THIS DUST CONTROL.
 - ALL AGGREGATE SUBBASE AND AGGREGATE BASE MATERIAL AND THE HANDLING AND PLACEMENT THEREOF, SHALL BE IN CONFORMANCE WITH CALTRANS STANDARD SPECIFICATIONS. AGGREGATE SUBBASE SHALL BE CLASS 1. AGGREGATE BASE SHALL BE CLASS 2. (RECLAIMED MATERIAL IS NOT APPROVED FOR USE IN THE CITY). COMPACT TO A MINIMUM OF 95% RELATIVE COMPACTION.
 - A PRIME COAT OF LIQUID ASPHALT, GRADE MC-70, CONFORMING TO CALTRANS STANDARD SPECIFICATIONS, MAY BE APPLIED AT THE APPROXIMATE TOTAL RATE OF 0.25+ GALLONS PER SQUARE YARD TO THE SURFACE OF AGGREGATE BASE PRIOR TO PLACEMENT OF ASPHALT CONCRETE, IF THERE IS TO BE A DELAY IN PLACING THE ASPHALT CONCRETE PAVEMENT.
 - ASPHALT CONCRETE (AC) SHALL CONSIST OF A MIXTURE OF SAND, MINERAL AGGREGATE, AND LIQUID ASPHALT, DESIGNATED AS CALTRANS STANDARD SPECIFICATIONS, TYPE B, 1/2" MAXIMUM, MEDIUM GRADING, MIXED IN SUCH PROPORTIONS THAT THE PERCENTAGE BY WEIGHT WILL BE WITHIN:

SIEVE SIZES	OPERATING RANGE (% PASSING)
3/4"	100%
1/2"	95%
3/8"	80-95%
NO.4	59-66%
NO.8	43-49%
NO.30	22-27%
NO.200	3-8%

PLUS PAVING ASPHALT, VISCOSITY GRADE AR4000 AT 5 TO 6-1/2% OF THE COMBINED DRY AGGREGATES.

ACTUAL MIX DESIGN SHALL BE SUBMITTED TO THE OWNER'S CIVIL ENGINEER FOR APPROVAL AT LEAST 10 WORKING DAYS PRIOR TO STARTING ANY PAVING WORK.
 - PAINT BINDER OF ASPHALT EMULSION, GRADE CRS-1, CONFORMING TO CALTRANS STANDARD SPECIFICATIONS, SHALL BE APPLIED TO EXISTING ASPHALT CONCRETE SURFACES AND VERTICAL CONCRETE SURFACES TO RECEIVE ASPHALT CONCRETE.
 - MATERIALS AND INSTALLATION OF PORTLAND CEMENT CONCRETE CURB, GUTTER AND SIDEWALK SHALL CONFORM TO THE APPLICABLE SECTIONS OF THE CALTRANS STANDARD SPECIFICATIONS AND THE CITY STANDARD SPECIFICATIONS AND DETAILS.
 - EXISTING A.C. SURFACE SHALL BE SAW CUT TO A NEAT STRAIGHT LINE PARALLEL WITH THE STREET CENTERLINE AND THE EXPOSED EDGE SHALL BE TACKED WITH EMULSION PRIOR TO PAVING, WHEN TRENCHING THROUGH CURB, GUTTER AND SIDEWALK. A SAW CUT WILL BE USED, WHERE EXISTING PAVEMENT IS TRENCHED, REPLACE WITH 3" A.C. AND A.B. MINIMUM OR MATCH THE EXISTING SECTION PLUS 2", WHICHEVER IS GREATER. THE EXPOSED BASE MATERIAL SHALL BE GRADED, RECOMPACTED AND RESEALED PRIOR TO REPAVING.
 - ALL VALVE BOXES AND MANHOLES TO BE SET FLUSH WITH FINISHED GRADE, UNLESS OTHERWISE NOTED.
 - APPROVAL OF THE CITY ENGINEER OR HIS AUTHORIZED REPRESENTATIVE, IS REQUIRED ON COMPLETED WORK PRIOR TO (A) PLACING OF ANY CONCRETE, (B) PLACING OF AGGREGATE BASE, (C) PLACING OF ASPHALTIC CONCRETE, (D) BACK FILLING TRENCHES FOR PIPE, WORK DONE WITHOUT SUCH APPROVAL, SHALL BE AT THE CONTRACTOR'S RISK. SUCH APPROVAL SHALL NOT RELIEVE THE CONTRACTOR FROM THE RESPONSIBILITY OF PERFORMING THE WORK IN AN ACCEPTABLE MANNER. REVIEW MAY INCLUDE SURVEY OF SUBBASE, BASE, AND AC/PCC FINISHED GRADE TO VERIFY GRADES.
- GRADING TOLERANCES SHALL BE AS FOLLOWS:
- | AREA | TOLERANCE |
|-----------------|-----------|
| CURB & GUTTER | 0.01 FEET |
| PAVEMENT | 0.02 FEET |
| BASE OR SUBBASE | 0.05 FEET |
- PRIOR TO PERFORMING THE FINAL GRADING AND SUB-GRADE COMPACTION FOR THE PAVED AREAS, THE CONTRACTOR SHALL REVIEW THE PROPOSED GRADES WITH THE MPWMD'S ENGINEER AND COMPLY WITH HIS REQUESTS FOR ANY MINOR GRADE CHANGES.
 - NOT USED
 - PAVEMENT MARKERS SHALL CONFORM TO SECTION 85 OF THE CALTRANS STANDARD SPECIFICATIONS AND THE SUPPLEMENTARY CONDITIONS.
 - ALL GRADING SHALL CONFORM TO APPROVED SPECIFICATIONS PRESENTED HEREON OR ATTACHED HERETO IN THE SPECIAL PROVISIONS. ALL GRADING WORK SHALL BE OBSERVED AND APPROVED BY THE GEOTECHNICAL ENGINEER. THE GEOTECHNICAL ENGINEER SHALL BE NOTIFIED AT LEAST TWO (2) WORKING DAYS BEFORE BEGINNING ANY GRADING. UNOBSERVED AND UNAPPROVED GRADING WORK SHALL BE REMOVED AND REPLACED UNDER OBSERVATION.
 - QUALITY ASSURANCE: FIELD OBSERVATION AND TESTING OF THE EARTHWORK CONSTRUCTION SHALL BE COORDINATED BY THE OWNER'S CIVIL ENGINEER. EARTHWORK THAT IN THE OPINION OF THE ENGINEER, DOES NOT CONFORM TO THE PLANS, SHALL BE REMOVED AND REPLACED OR REWORKED UNTIL, IN THE OPINION OF THE ENGINEER, SATISFACTORY EARTHWORK CONSTRUCTION HAS BEEN OBTAINED. REWORKING, OR REMOVAL AND REPLACEMENT OF EARTHWORK CONSTRUCTION AS DISCUSSED IN THIS PARAGRAPH SHALL BE AT THE SOLE EXPENSE OF THE CONTRACTOR.
 - CAPE SEAL SHALL BE INSTALLED PER CAL TRANS SPECIFICATIONS FOR "DOUBLE SEAL COAT" PER SECTION 37-1.

0451FGF.DWG 04/17/18 08:30:21 AM PDT

REV	DATE	BY	DESCRIPTION
B	5/25/18	MAC	ISSUED FOR BID
A	4/05/18	MAC	1ST SUBMITTAL

SCALE:
HOR. N/A
VER. N/A

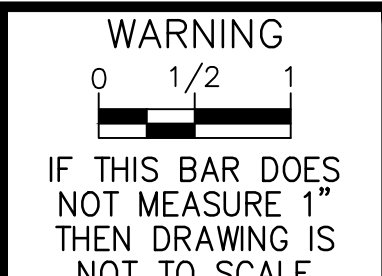

DESIGNED MAC
DRAWN TLA
CHECKED SPT

MAC Design Associates
CIVIL ENGINEERING * LAND PLANNING * BRIDGE DESIGN
1933 CLIFF DRIVE, SUITE 6, SANTA BARBARA, CALIF. 93109 (805) 957-4748



Pueblo Water Resources
4478 Market St., Suite 705
Ventura, CA 93003
(805) 644-0470

GENERAL INFORMATION
MONTEREY PENINSULA WATER MANAGEMENT DISTRICT
SANTA MARGARITA ASR FACILITY SITE EXPANSION
1910 GENERAL JIM MOORE BOULEVARD

PROJECT NO. W.O. 0451
1 of 9

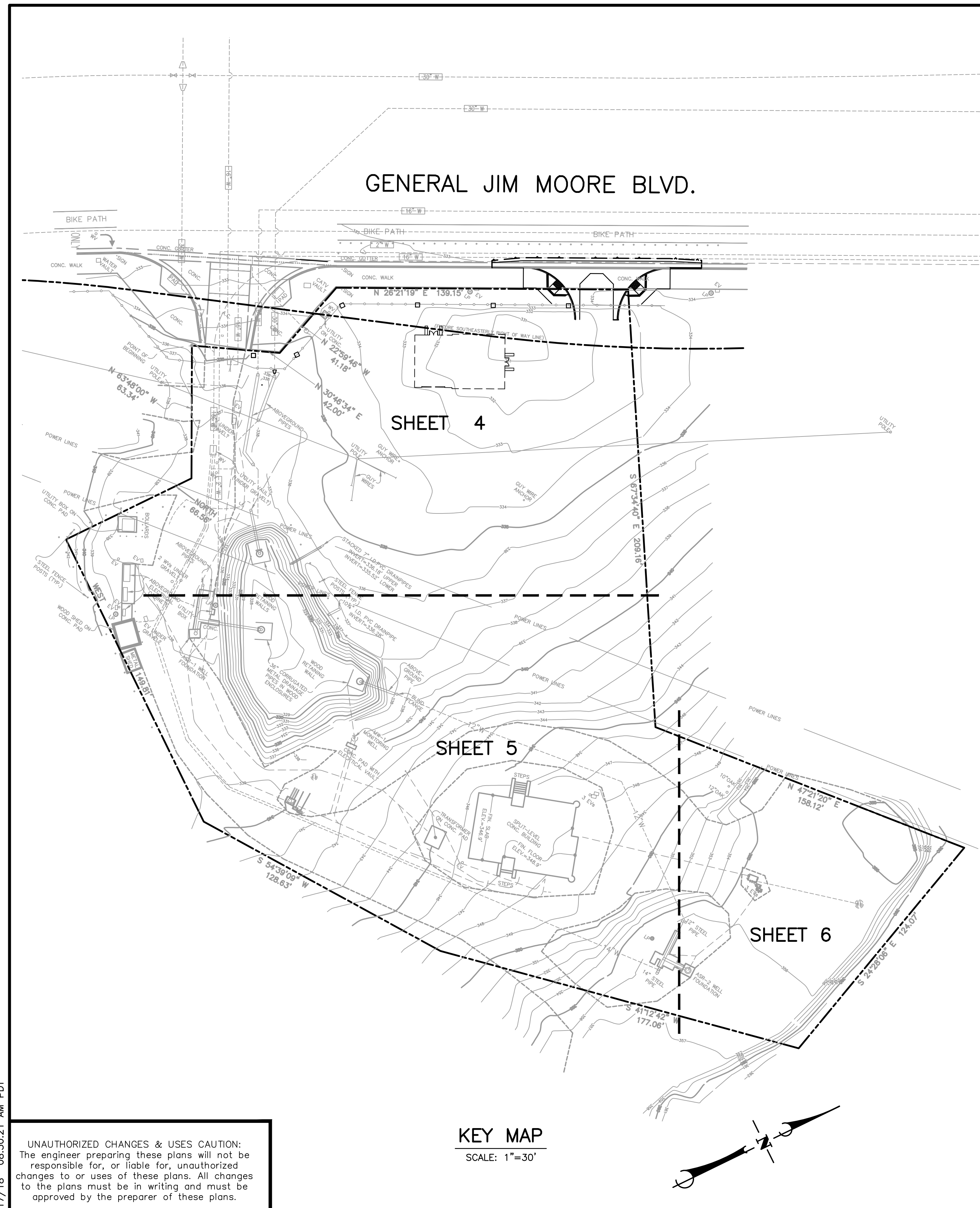

PIPE MATERIAL TABLE

UTILITY	MATERIAL
WATER	12" - D.I.P. C250 16" - D.I.P. C250 30" - D.I.P. C250 w/RESTRAINED LOCKING GASKETS ALL D.I.P. MORTAR LINED & BITUMINOUS COATED w/RESTRAINED LOCKING GASKETS.
WATER VALVE	GATE VALVE - MAINS 12" & SMALLER BUTTERFLY VALVE - MAINS 12" & LARGER
FITTINGS	M.J. FITTINGS, DUCTILE IRON, CM LINED, W/EBBA IRON MEGALUG RESTRAINTS.

NOTE:
PIPE AND FITTINGS PRE-PURCHASED AND PROVIDED BY OWNER;
SEE MATERIALS LIST. ALL MISCELLANEOUS FITTINGS AND APPURTENANCES TO BE PROVIDED BY CONTRACTOR.

EARTHWORK

ESTIMATED EARTHWORK QUANTITIES:	CUT	FILL
SITE GRADING	2570 C.Y.	2175 C.Y.
TRENCH GRADING	10 C.Y.	5 C.Y.
SUBTOTAL	2580 C.Y.	2180 C.Y.
SHRINKAGE @ 15%	-400 C.Y.	
TOTAL	2180 C.Y.	2180 C.Y.

IMPORT = 0 C.Y.
EXPORT = 0 C.Y.

- (1) ESTIMATED QUANTITIES SHOWN ABOVE ARE COMPUTED FROM EXISTING GROUND ELEVATIONS TO THE PROPOSED ELEVATIONS ON THIS PLAN.
- (2) MATERIAL GENERATED THROUGH CLEARING & GRUBBING OPERATIONS WILL BE USED FOR EMBANKMENT AND NOT BE REMOVED FROM THE SITE.
- (3) FOR THE PURPOSE OF THESE EARTHWORK CALCULATIONS, THE PAVEMENT STRUCTURAL SECTION IS ASSUMED TO BE 0.75'.
- (4) NO MATERIAL WILL BE EXPORTED OR IMPORTED FROM THE SITE. THE BERMS LOCATED EASTERLY OF GENERAL JIM MOORE BOULEVARD AND NORTHERLY OF THE PROPOSED POND EXPANSION WILL BE ADJUSTED AS REQUIRED TO ENSURE EARTHWORK WILL BALANCE ONSITE.

LEGEND

--- 16"W ---	EXIST. WATER LINE	BLDG	BUILDING
□ EV	EXIST. ELECT. VAULT	C.L.	CENTERLINE
○	EXIST. WATER VALVE	CONT	CONTINUOUS
---	EXIST. FENCE LINE	CTR	CENTER
---	PROPERTY LINE	CMP	CORRIGATED METAL PIPE
---	PROPOSED 30" RAW W.L.	CMU	CEMENT MORTOR UNIT
---	PROPOSED 30" TREATED W.L.	DIA.	DIAMETER
---	PROPOSED STORM DRAIN LINE	DET	DETAIL
---	PROPOSED RETAINING WALL	ELEV	ELEVATION
■	PROPOSED CATCH BASIN	FLG	FLANGE
⊗	PROPOSED WATER VALVE	STL	STEEL
● DS	PROPOSED DOWNSPOUT	SHT	SHEET
		TF	TOP OF FOOTING
		TW	TOP OF WALL
		TYP	TYPICAL

INDEX TO DRAWINGS

1. GENERAL INFORMATION
2. KEY MAP
3. DEMOLITION PLAN
4. FINAL GRADING & DRAINAGE PLAN
5. FINAL GRADING & DRAINAGE PLAN
6. FINAL GRADING & DRAINAGE PLAN
7. CROSS SECTION & DETAILS
8. RETAINING WALL PROFILE & DETAILS
9. EROSION CONTROL PLAN

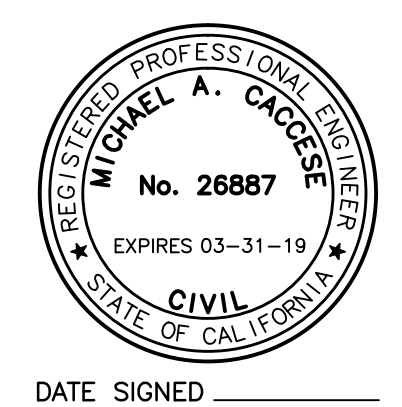

0451FCP.DWG 04/17/18 08:50:21 AM PDT

UNAUTHORIZED CHANGES & USES CAUTION:
The engineer preparing these plans will not be responsible for, or liable for, unauthorized changes to or uses of these plans. All changes to the plans must be in writing and must be approved by the preparer of these plans.

REV	DATE	BY	DESCRIPTION
B	5/25/18	MAC	ISSUED FOR BID
A	4/05/18	MAC	1ST SUBMITTAL

SCALE:
HOR. 1"=30'
VER. N/A

WARNING
IF THIS BAR DOES NOT MEASURE 1" THEN DRAWING IS NOT TO SCALE

DESIGNED MAC
DRAWN TLA
CHECKED SPT

MAC Design Associates
CIVIL ENGINEERING * LAND PLANNING * BRIDGE DESIGN
1933 CLIFF DRIVE, SUITE 6, SANTA BARBARA, CALIF. 93109 (805) 957-4748

PUEBLO water resources

Pueblo Water Resources
4478 Market St., Suite 705
Ventura, CA 93003
(805) 644-0470

KEY MAP
MONTEREY PENINSULA WATER MANAGEMENT DISTRICT
SANTA MARGARITA ASR FACILITY SITE EXPANSION
1910 GENERAL JIM MOORE BOULEVARD

PROJECT NO.
W.O. 0451
2 of 9

LEGEND

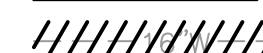
 REMOVE EXIST. UTILITY LINE AND REPLACE AND/OR CONNECT WITH NEW UTILITY PER CONSTRUCTION NOTES ON SHEET 4

DEMOLITION NOTES

- 1** REMOVE AND SALVAGE PORTION OF EXISTING FENCE TO CONSTRUCT SECURITY WALL, COLUMNS AND ROADWAY ENTRANCE SEE SHEET 4 FOR FENCE RECONSTRUCTION.
- 2** REMOVE EXIST FENCE
- 3** REMOVE AND SALVAGE EXISTING GATE SEE SHEET 4 FOR GATE AND FENCE RECONSTRUCTION.

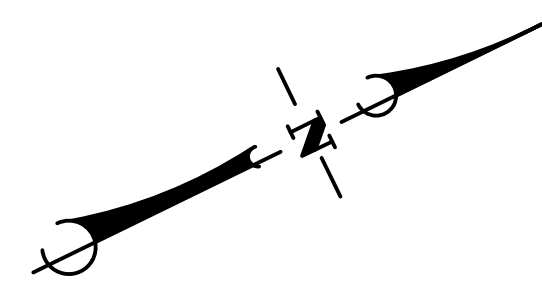
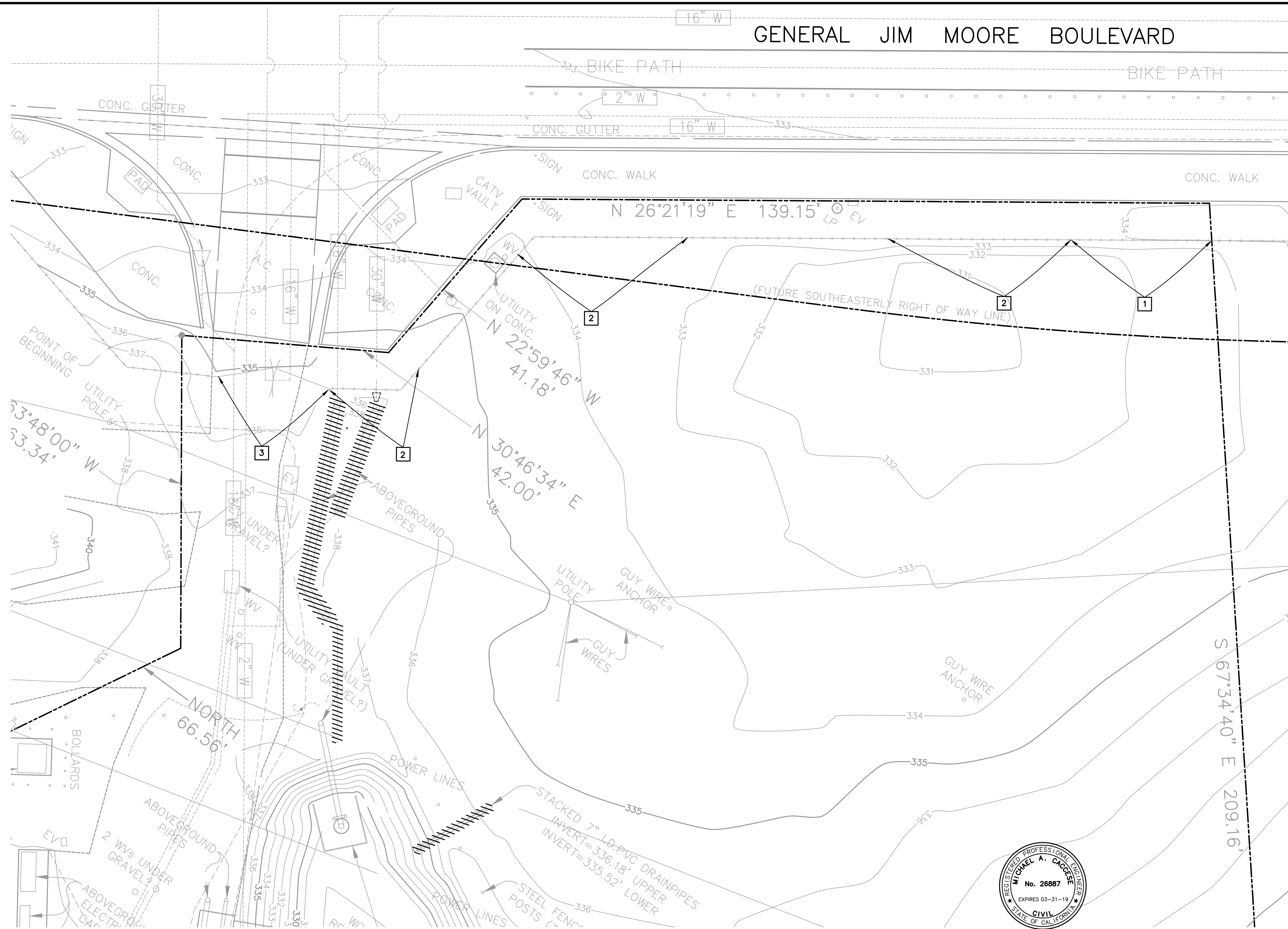

SCALE: 1"=10'
0 10 20 30 40

UNAUTHORIZED CHANGES & USES CAUTION:
The engineer preparing these plans will not be responsible for, or liable for, unauthorized changes to or uses of these plans. All changes to the plans must be in writing and must be approved by the preparer of these plans.



DATE SIGNED _____

0451FGP.DWG 04/17/18 08:50:21 AM PDT

REV	DATE	BY	DESCRIPTION
B	5/25/18	MAC	ISSUED FOR BID
A	4/05/18	MAC	1ST SUBMITTAL

SCALE:
HOR. 1"=10'
VER. 1"=N/A

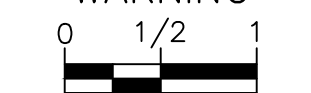
WARNING

IF THIS BAR DOES NOT MEASURE 1" THEN DRAWING IS NOT TO SCALE

DESIGNED MAC
DRAWN TLA
CHECKED SPT

MAC Design Associates
CIVIL ENGINEERING * LAND PLANNING * BRIDGE DESIGN
1933 CLIFF DRIVE, SUITE 6, SANTA BARBARA, CALIF. 93109 (805) 957-4748



Pueblo Water Resources
4478 Market St., Suite 705
Ventura, CA 93003
(805) 644-0470

DEMOLITION PLAN
MONTEREY PENINSULA WATER MANAGEMENT DISTRICT
SANTA MARGARITA ASR FACILITY SITE EXPANSION
1910 GENERAL JIM MOORE BOULEVARD

PROJECT NO.
W.O. 0451
3 of 9

GENERAL JIM MOORE BOULEVARD

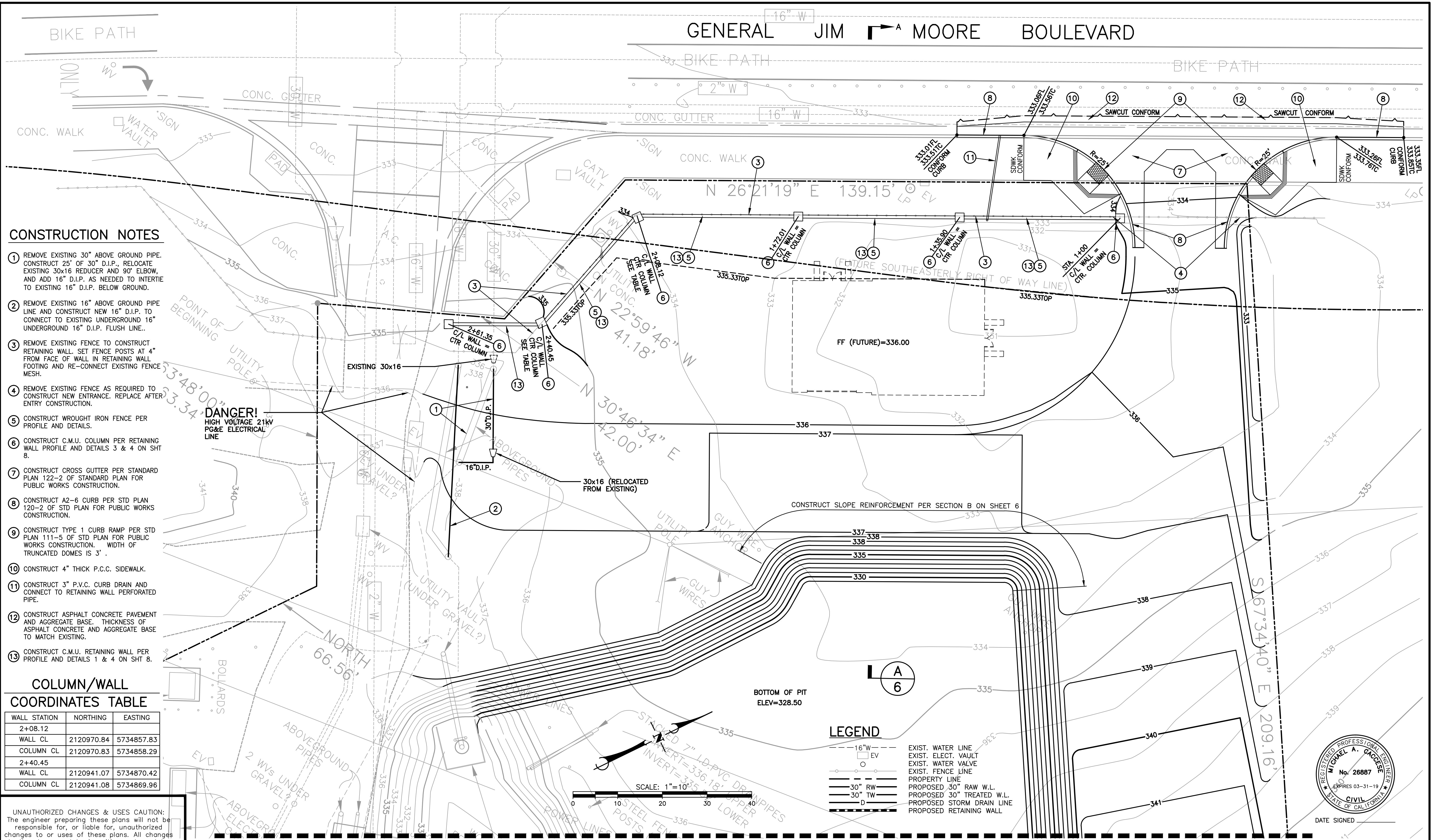

CONSTRUCTION NOTES

- 1 REMOVE EXISTING 30" ABOVE GROUND PIPE. CONSTRUCT 25' OF 30" D.I.P., RELOCATE EXISTING 30x16 REDUCER AND 90° ELBOW, AND ADD 16" D.I.P. AS NEEDED TO INTERTIE TO EXISTING 16" D.I.P. BELOW GROUND.
- 2 REMOVE EXISTING 16" ABOVE GROUND PIPE LINE AND CONSTRUCT NEW 16" D.I.P. TO CONNECT TO EXISTING UNDERGROUND 16" UNDERGROUND 16" D.I.P. FLUSH LINE.
- 3 REMOVE EXISTING FENCE TO CONSTRUCT RETAINING WALL. SET FENCE POSTS AT 4" FROM FACE OF WALL IN RETAINING WALL FOOTING AND RE-CONNECT EXISTING FENCE MESH.
- 4 REMOVE EXISTING FENCE AS REQUIRED TO CONSTRUCT NEW ENTRANCE. REPLACE AFTER ENTRY CONSTRUCTION.
- 5 CONSTRUCT WROUGHT IRON FENCE PER PROFILE AND DETAILS.
- 6 CONSTRUCT C.M.U. COLUMN PER RETAINING WALL PROFILE AND DETAILS 3 & 4 ON SHT 8.
- 7 CONSTRUCT CROSS GUTTER PER STANDARD PLAN 122-2 OF STANDARD PLAN FOR PUBLIC WORKS CONSTRUCTION.
- 8 CONSTRUCT A2-6 CURB PER STD PLAN 120-2 OF STD PLAN FOR PUBLIC WORKS CONSTRUCTION.
- 9 CONSTRUCT TYPE 1 CURB RAMP PER STD PLAN 111-5 OF STD PLAN FOR PUBLIC WORKS CONSTRUCTION. WIDTH OF TRUNCATED DOMES IS 3'.
- 10 CONSTRUCT 4" THICK P.C.C. SIDEWALK.
- 11 CONSTRUCT 3" P.V.C. CURB DRAIN AND CONNECT TO RETAINING WALL PERFORATED PIPE.
- 12 CONSTRUCT ASPHALT CONCRETE PAVEMENT AND AGGREGATE BASE. THICKNESS OF ASPHALT CONCRETE AND AGGREGATE BASE TO MATCH EXISTING.
- 13 CONSTRUCT C.M.U. RETAINING WALL PER PROFILE AND DETAILS 1 & 4 ON SHT 8.

COLUMN/WALL COORDINATES TABLE

WALL STATION	NORTHING	EASTING
2+08.12	2120970.84	5734857.83
WALL CL	2120970.84	5734857.83
COLUMN CL	2120970.83	5734858.29
2+40.45	2120941.07	5734870.42
WALL CL	2120941.07	5734870.42
COLUMN CL	2120941.08	5734869.96

UNAUTHORIZED CHANGES & USES CAUTION: The engineer preparing these plans will not be responsible for, or liable for, unauthorized changes to or uses of these plans. All changes to the plans must be in writing and must be approved by the preparer of these plans.

DANGER!
HIGH VOLTAGE 21KV
PG&E ELECTRICAL
LINE

LEGEND

- - - 16"W - - - EXIST. WATER LINE
- EV EXIST. ELECT. VAULT
- EXIST. WATER VALVE
- EXIST. FENCE LINE
- PROPERTY LINE
- 30" RW PROPOSED 30" RAW W.L.
- 30" TW PROPOSED 30" TREATED W.L.
- - - D - - - PROPOSED STORM DRAIN LINE
- PROPOSED RETAINING WALL

SCALE: 1"=10'

MATCH LINE - SEE SHEET 5

0451FGP.DWG 04/17/18 08:50:21 AM PDT

REV	DATE	BY	DESCRIPTION
B	5/25/18	MAC	ISSUED FOR BID
A	4/05/18	MAC	1ST SUBMITTAL
REV	DATE	BY	DESCRIPTION

SCALE:
HOR. 1"=10'
VER. 1"=N/A

WARNING
IF THIS BAR DOES NOT MEASURE 1" THEN DRAWING IS NOT TO SCALE

DESIGNED MAC
DRAWN TLA
CHECKED SPT

MAC Design Associates
CIVIL ENGINEERING * LAND PLANNING * BRIDGE DESIGN
1933 CLIFF DRIVE, SUITE 6, SANTA BARBARA, CALIF. 93109 (805) 957-4748



Pueblo Water Resources
4478 Market St., Suite 705
Ventura, CA 93003
(805) 644-0470

FINAL GRADING PLAN
MONTEREY PENINSULA WATER MANAGEMENT DISTRICT
SANTA MARGARITA ASR FACILITY SITE EXPANSION
1910 GENERAL JIM MOORE BOULEVARD

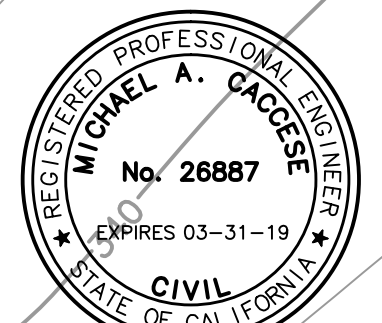

DATE SIGNED

PROJECT NO. W.O. 0451
4 of 9

MATCH LINE - SEE SHEET 4

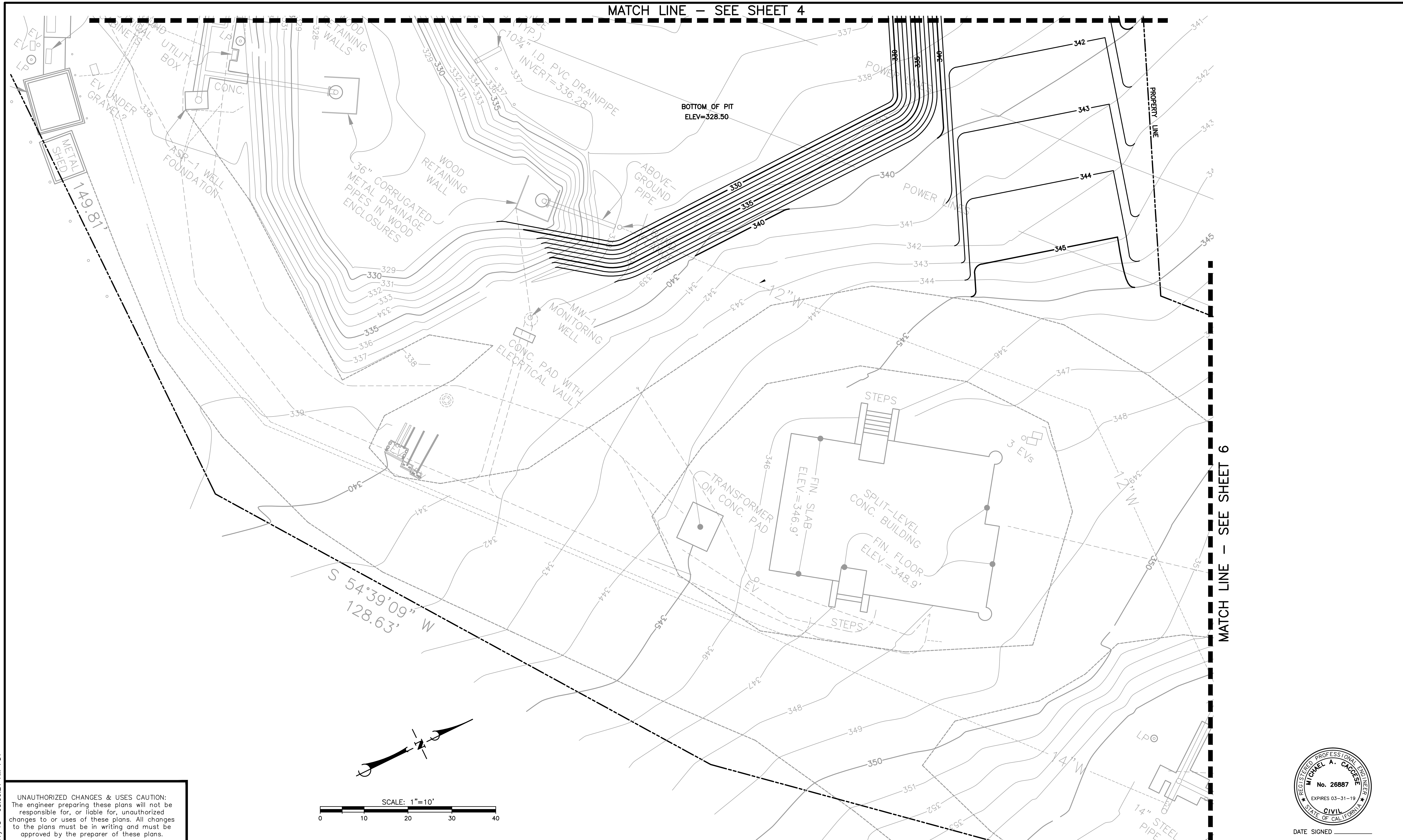

MATCH LINE - SEE SHEET 6

UNAUTHORIZED CHANGES & USES CAUTION:
The engineer preparing these plans will not be responsible for, or liable for, unauthorized changes to or uses of these plans. All changes to the plans must be in writing and must be approved by the preparer of these plans.

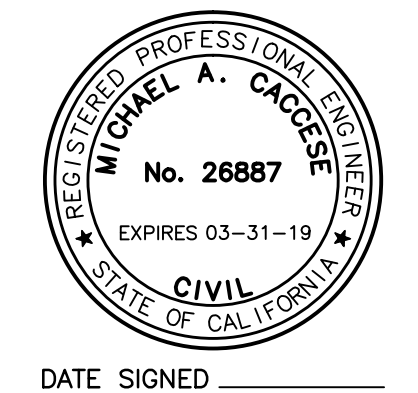
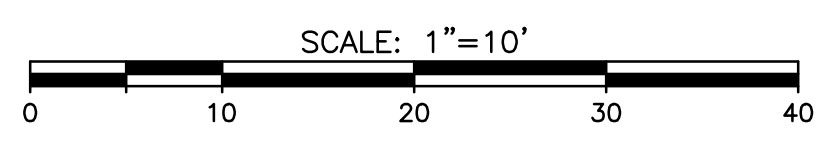

0451FGP.DWG 04/17/18 08:50:21 AM PDT

REV	DATE	BY	DESCRIPTION
B	5/25/18	MAC	ISSUED FOR BID
A	4/05/18	MAC	1ST SUBMITTAL

SCALE:
HOR. 1"=10'
VER. N/A

WARNING
IF THIS BAR DOES NOT MEASURE 1" THEN DRAWING IS NOT TO SCALE

DESIGNED MAC
DRAWN TLA
CHECKED SPT

MAC Design Associates
CIVIL ENGINEERING • LAND PLANNING • BRIDGE DESIGN
1933 CLIFF DRIVE, SUITE 6, SANTA BARBARA, CALIF. 93109 (805) 957-4748



Pueblo Water Resources
4478 Market St., Suite 705
Ventura, CA 93003
(805) 644-0470

FINAL GRADING PLAN
MONTEREY PENINSULA WATER MANAGEMENT DISTRICT
SANTA MARGARITA ASR FACILITY SITE EXPANSION
1910 GENERAL JIM MOORE BOULEVARD

PROJECT NO.
W.O. 0451
5 of 9

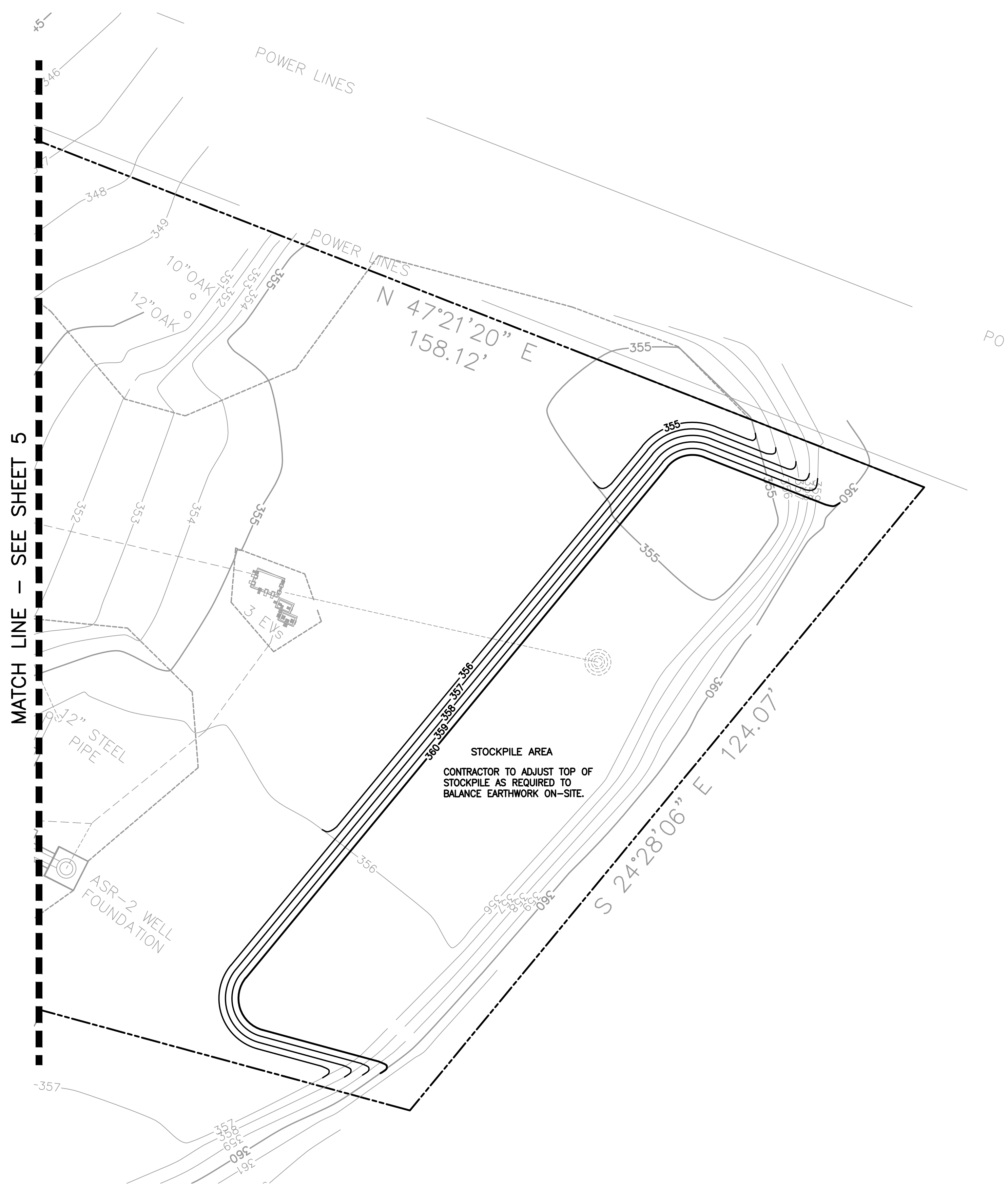

UNAUTHORIZED CHANGES & USES CAUTION:
The engineer preparing these plans will not be responsible for, or liable for, unauthorized changes to or uses of these plans. All changes to the plans must be in writing and must be approved by the preparer of these plans.

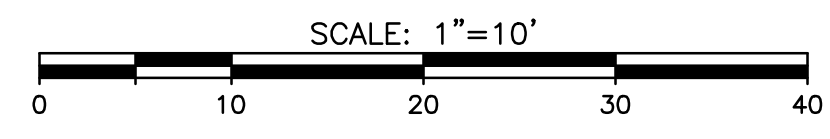

DATE SIGNED _____

0451FGP.DWG 04/17/18 08:50:21 AM PDT

REV	DATE	BY	DESCRIPTION
B	5/25/18	MAC	ISSUED FOR BID
A	4/05/18	MAC	1ST SUBMITTAL

SCALE:
HOR. 1"=10'
VER. N/A

WARNING
IF THIS BAR DOES NOT MEASURE 1" THEN DRAWING IS NOT TO SCALE

DESIGNED MAC
DRAWN TLA
CHECKED SPT

MAC Design Associates
CIVIL ENGINEERING * LAND PLANNING * BRIDGE DESIGN
1933 CLIFF DRIVE, SUITE 6, SANTA BARBARA, CALIF. 93109 (805) 957-4748



Pueblo Water Resources
4478 Market St., Suite 705
Ventura, CA 93003
(805) 644-0470

FINAL GRADING PLAN
MONTEREY PENINSULA WATER MANAGEMENT DISTRICT
SANTA MARGARITA ASR FACILITY SITE EXPANSION
1910 GENERAL JIM MOORE BOULEVARD

PROJECT NO.
W.O. 0451
6 of 9

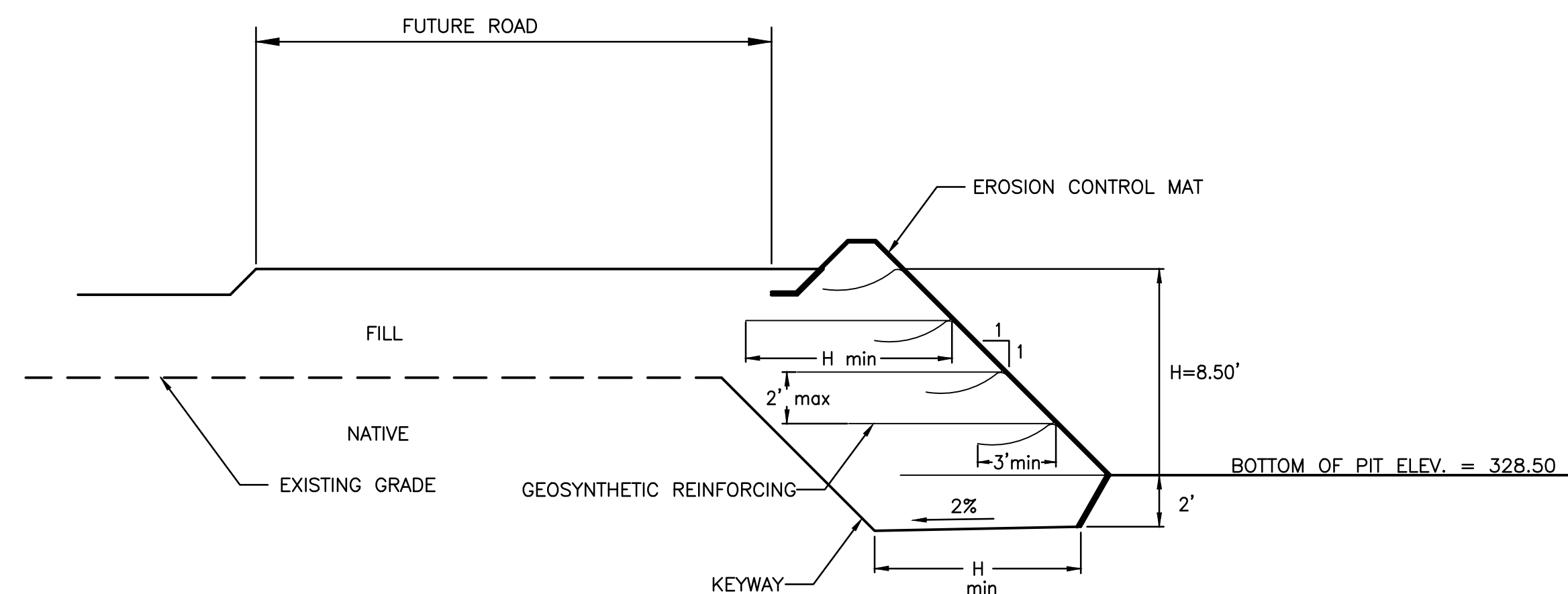

B SECTION B
6 SCALE: 1"=5'

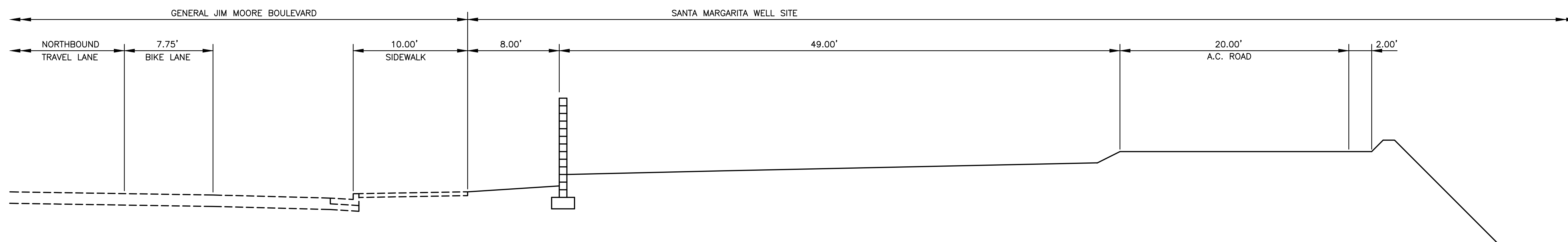

A SECTION A-A
6 SCALE: 1"=5'

UNAUTHORIZED CHANGES & USES CAUTION:
The engineer preparing these plans will not be responsible for, or liable for, unauthorized changes to or uses of these plans. All changes to the plans must be in writing and must be approved by the preparer of these plans.



0451FGP.DWG 04/17/18 08:50:21 AM PDT

REV	DATE	BY	DESCRIPTION
B	5/25/18	MAC	ISSUED FOR BID
A	4/05/18	MAC	1ST SUBMITTAL

SCALE:
HOR. N/A
VER. N/A

WARNING
IF THIS BAR DOES NOT MEASURE 1" THEN DRAWING IS NOT TO SCALE

DESIGNED MAC
DRAWN TLA
CHECKED SPT

MAC Design Associates
CIVIL ENGINEERING * LAND PLANNING * BRIDGE DESIGN
1933 CLIFF DRIVE, SUITE 6, SANTA BARBARA, CALIF. 93109 (805) 957-4748



Pueblo Water Resources
4478 Market St., Suite 705
Ventura, CA 93003
(805) 644-0470

CROSS SECTION AND DETAILS
MONTEREY PENINSULA WATER MANAGEMENT DISTRICT
SANTA MARGARITA ASR FACILITY SITE EXPANSION
1910 GENERAL JIM MOORE BOULEVARD

PROJECT NO.
W.O. 0451

7 of 9

UNAUTHORIZED CHANGES & USES CAUTION:
The engineer preparing these plans will not be responsible for, or liable for, unauthorized changes to or uses of these plans. All changes to the plans must be in writing and must be approved by the preparer of these plans.

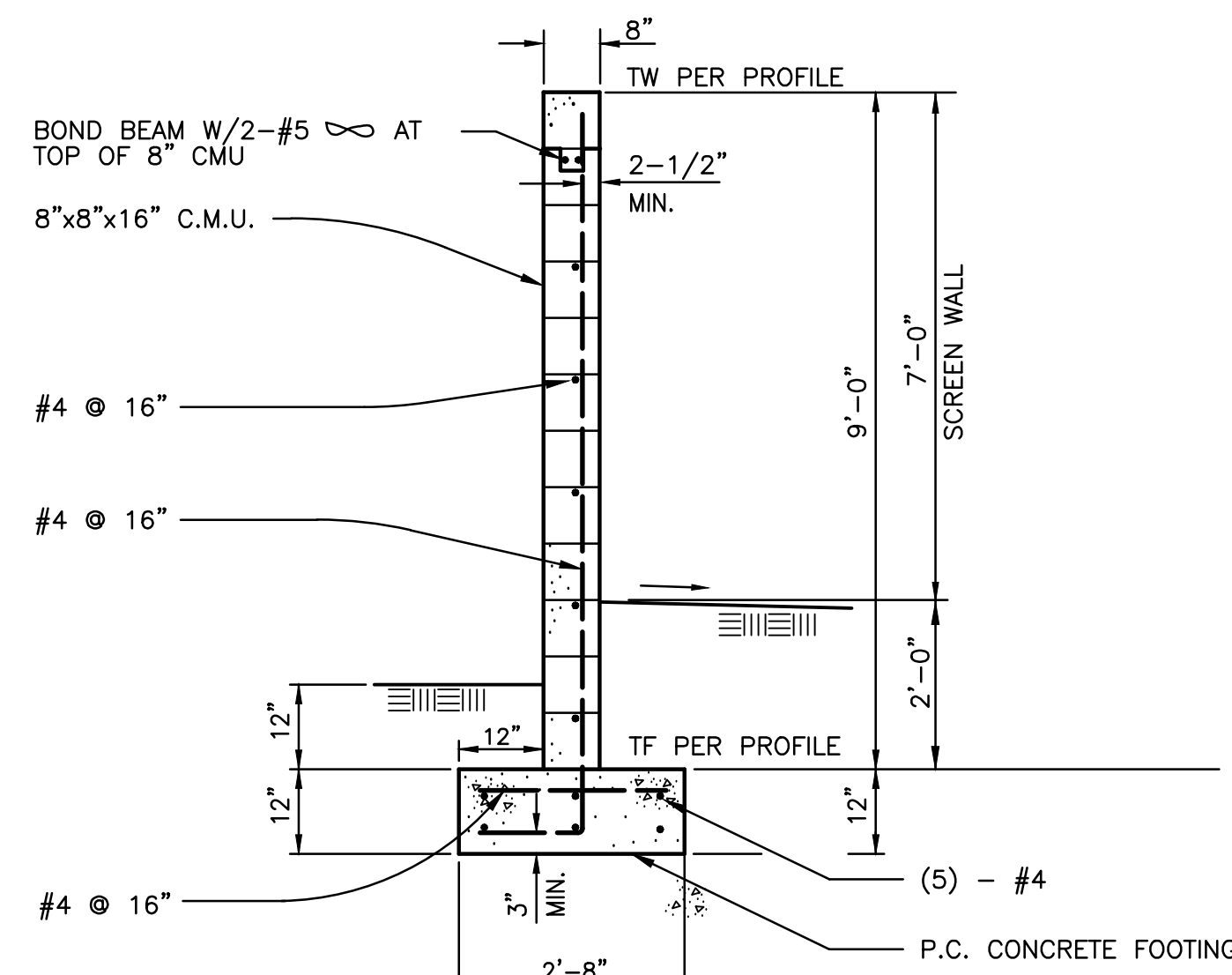

NOTE: SEE ARCHITECTS PLAN FOR PLASTER COATING AND FINISH DETAILS.
1 SCREEN WALL DETAIL
8 NO SCALE

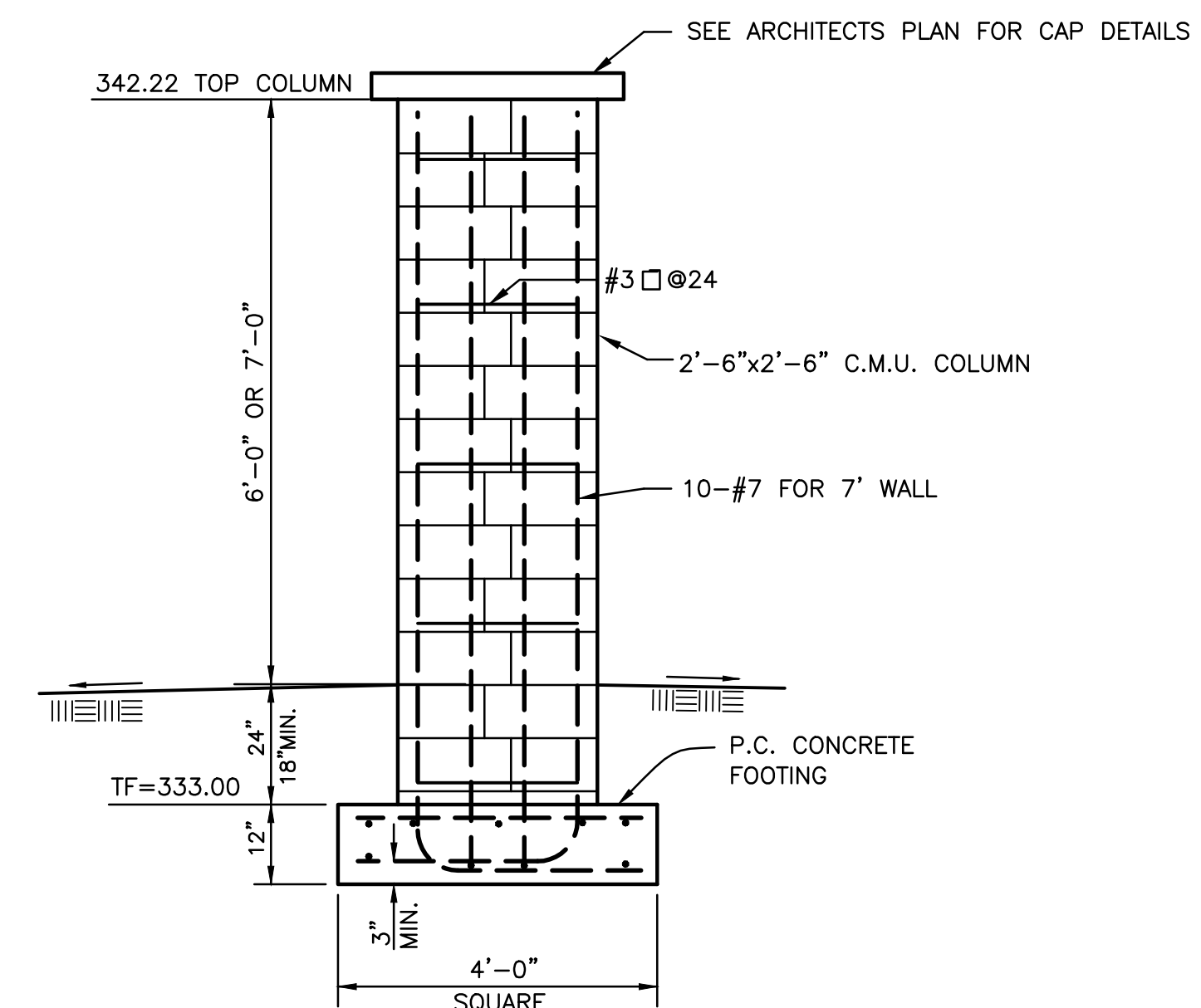

NOTES:
1. HORIZONTAL REINFORCEMENT FOR COLUMN IS NOT SHOWN. SEE COLUMN TYPICAL SECTION (DETAIL "A" THIS SHEET) FOR DETAILS.
2. SEE ARCHITECTS PLAN FOR PLASTER COATING AND FINISH DETAILS.
3 COLUMN DETAIL
8 SCALE: 1" = 2'-0"

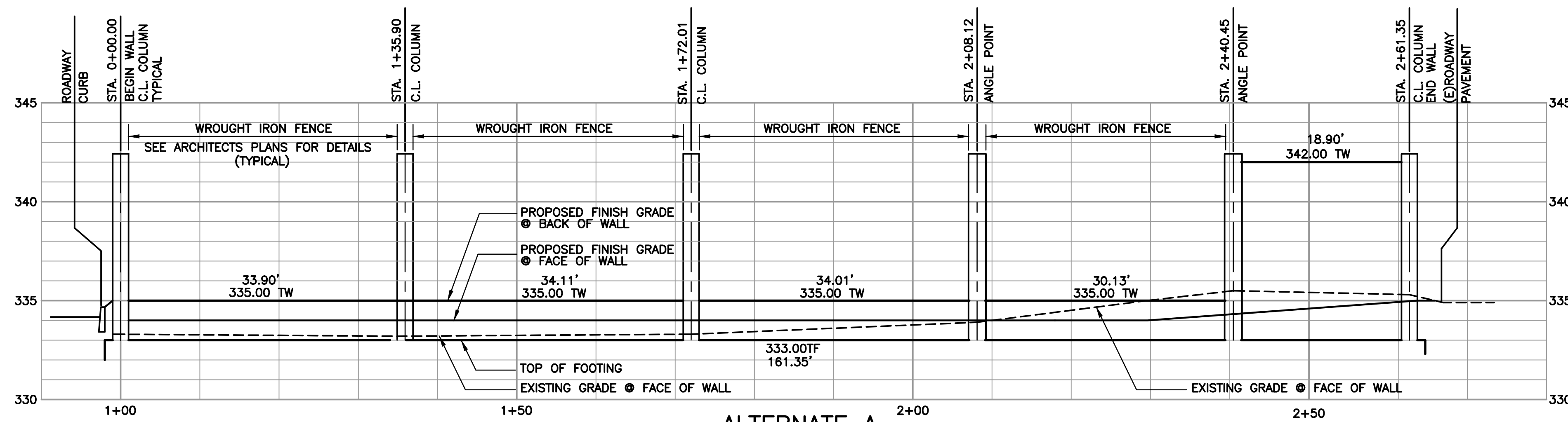

2A SCREEN WALL/WROUGHT IRON FENCE PROFILE
8 SCALE: HORIZ. 1" = 10', VERT. 1" = 4'

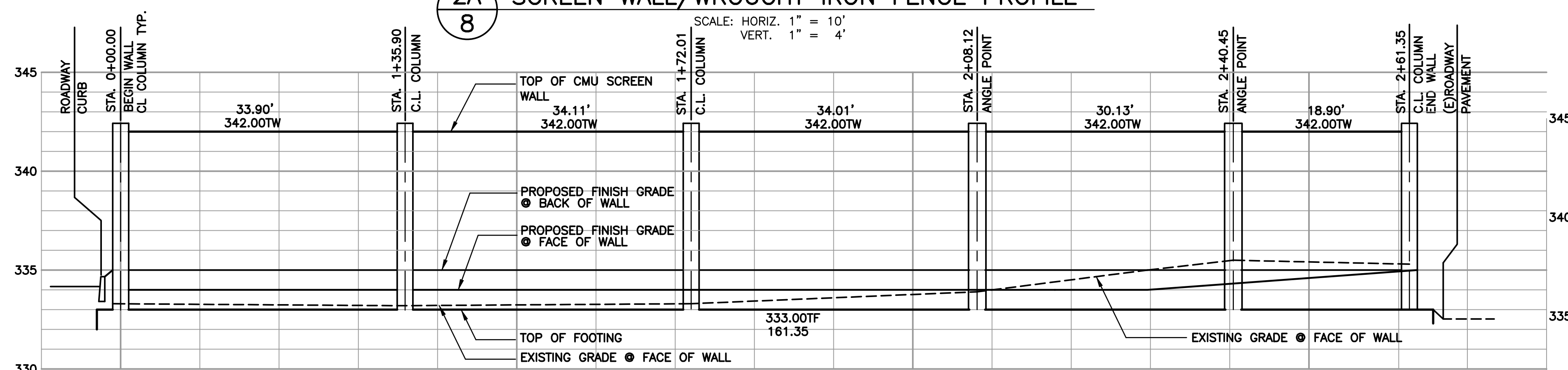

2B SCREEN WALL PROFILE
8 SCALE: HORIZ. 1" = 10', VERT. 1" = 4'

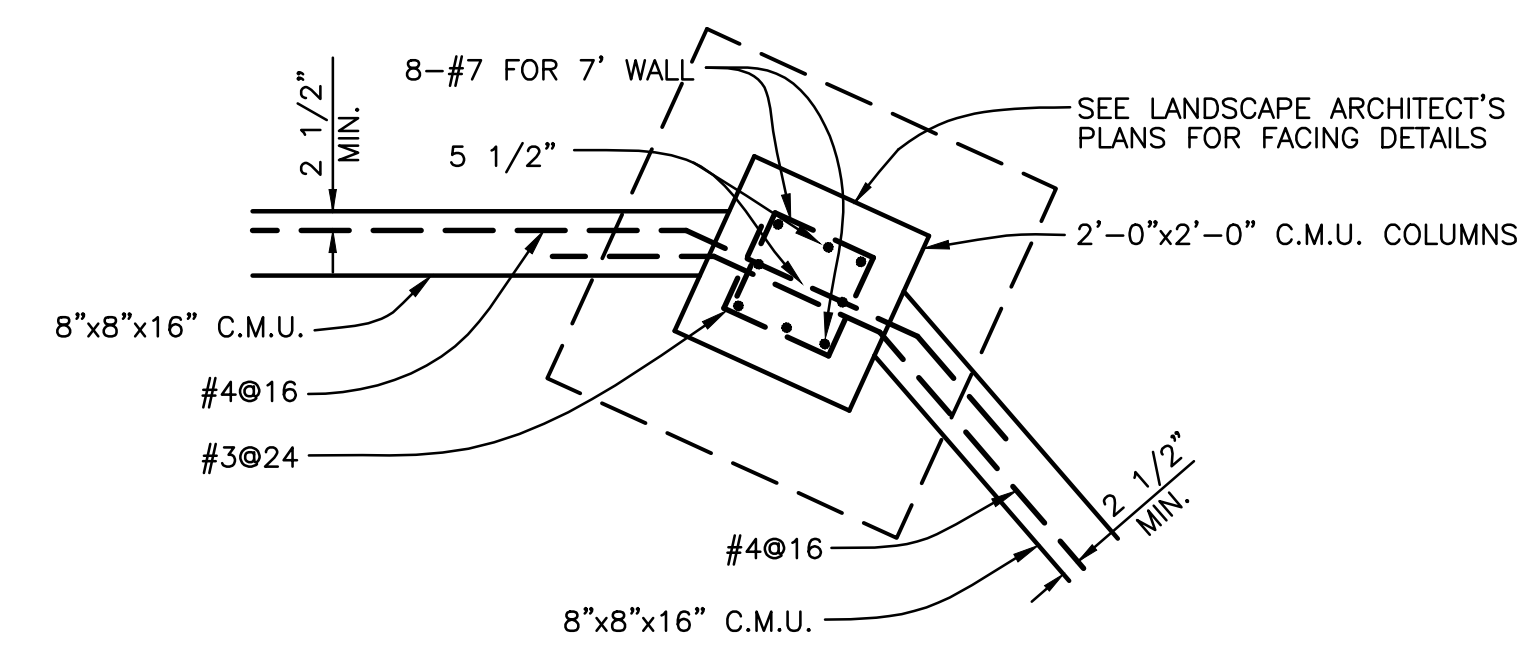

NOTES:
1. HORIZONTAL REINFORCEMENT IN WALL MUST BE CONTINUOUS THROUGH COLUMN. LAP REINFORCEMENT 40 BAR DIAMETERS MINIMUM.
2. VERTICAL REINFORCEMENT IN WALL IS NOT SHOWN. SEE SCREEN WALL DETAILS FOR INFORMATION.
4 COLUMN TYPICAL SECTION
7 SCALE: 1" = 2'-0"

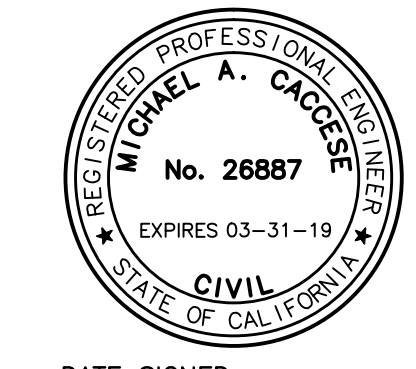

DATE SIGNED _____

0451FGP.DWG 04/17/18 08:50:21 AM PDT

REV	DATE	BY	DESCRIPTION
B	5/25/18	MAC	ISSUED FOR BID
A	4/05/18	MAC	1ST SUBMITTAL

SCALE:
HOR. 1"=10'
VER. 1"=2'

WARNING
0 1/2 1
IF THIS BAR DOES NOT MEASURE 1" THEN DRAWING IS NOT TO SCALE

DESIGNED: MAC
DRAWN: TLA
CHECKED: SPT

MAC Design Associates
CIVIL ENGINEERING * LAND PLANNING * BRIDGE DESIGN
1933 CLIFF DRIVE, SUITE 6, SANTA BARBARA, CALIF. 93109 (805) 957-4748



Pueblo Water Resources
4478 Market St., Suite 705
Ventura, CA 93003
(805) 644-0470

RETAINING WALL PROFILE AND DETAILS
MONTEREY PENINSULA WATER MANAGEMENT DISTRICT
SANTA MARGARITA ASR FACILITY SITE EXPANSION
1910 GENERAL JIM MOORE BOULEVARD

PROJECT NO. W.O. 0451
8 of 9

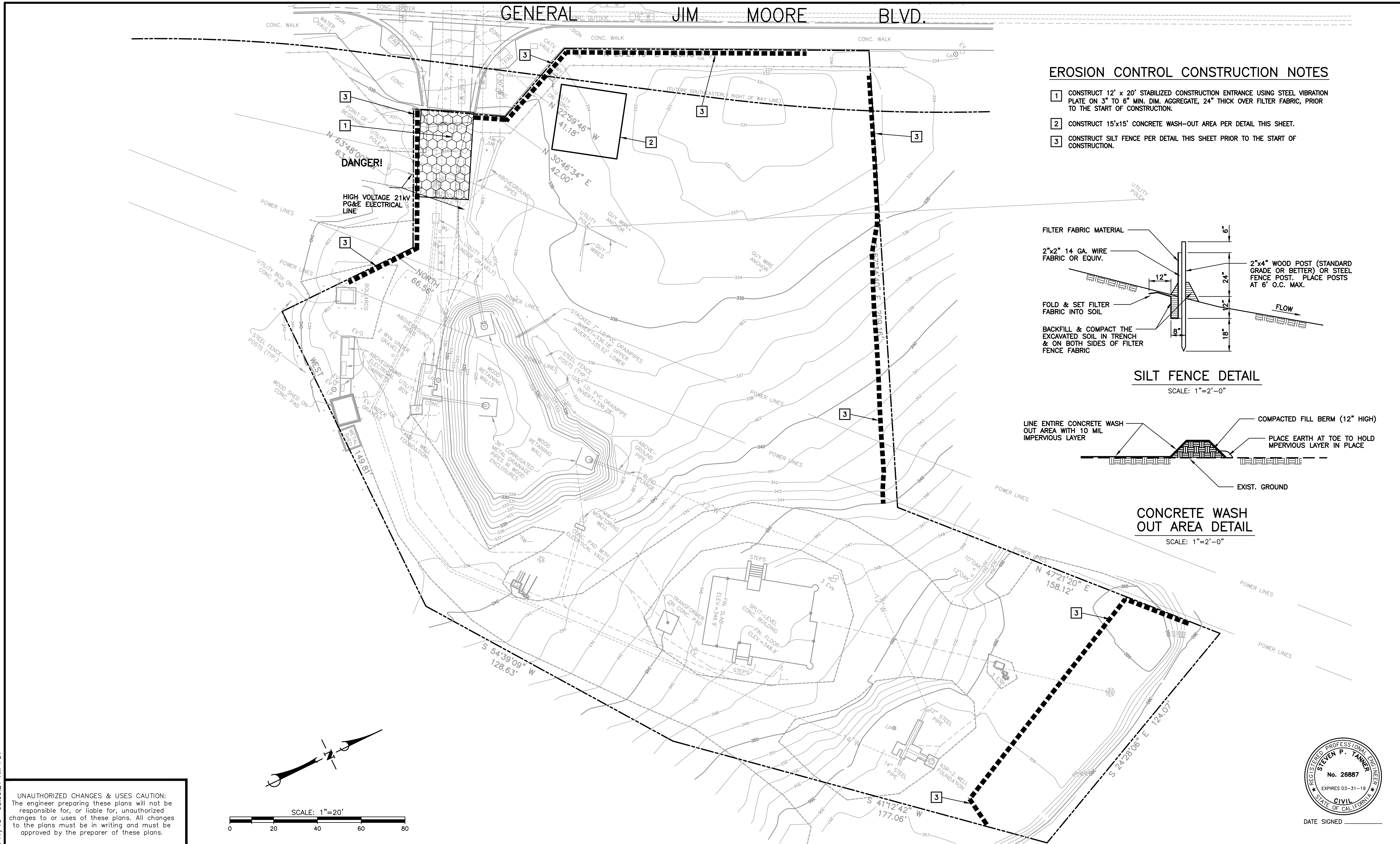

0451FGP.DWG 04/17/18 08:50:21 AM PDT

UNAUTHORIZED CHANGES & USES CAUTION:
The engineer preparing these plans will not be responsible for, or liable for, unauthorized changes to or uses of these plans. All changes to the plans must be in writing and must be approved by the preparer of these plans.

SCALE:	WARNING	DESIGNED	SPT
HOR. N/A	0 1/2 1	DRAWN	TLA
VER. N/A	IF THIS BAR DOES NOT MEASURE 1" THEN DRAWING IS NOT TO SCALE	CHECKED	MAC

MAC Design Associates
CIVIL ENGINEERING * LAND PLANNING * BRIDGE DESIGN
1933 CLIFF DRIVE, SUITE 6, SANTA BARBARA, CALIF. 93109 (805) 957-4748



Pueblo Water Resources
4478 Market St., Suite 705
Ventura, CA 93003
(805) 644-0470

EROSION CONTROL
MONTEREY PENINSULA WATER MANAGEMENT DISTRICT
SANTA MARGARITA ASR FACILITY SITE EXPANSION
1910 GENERAL JIM MOORE BOULEVARD

PROJECT NO.
W.O. 0451

9 of 9

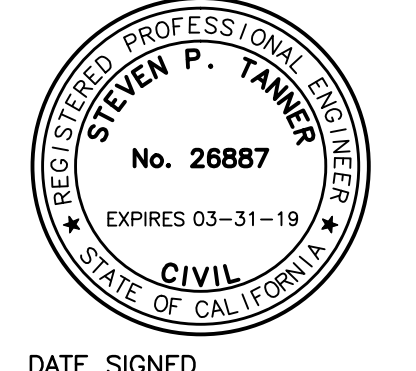

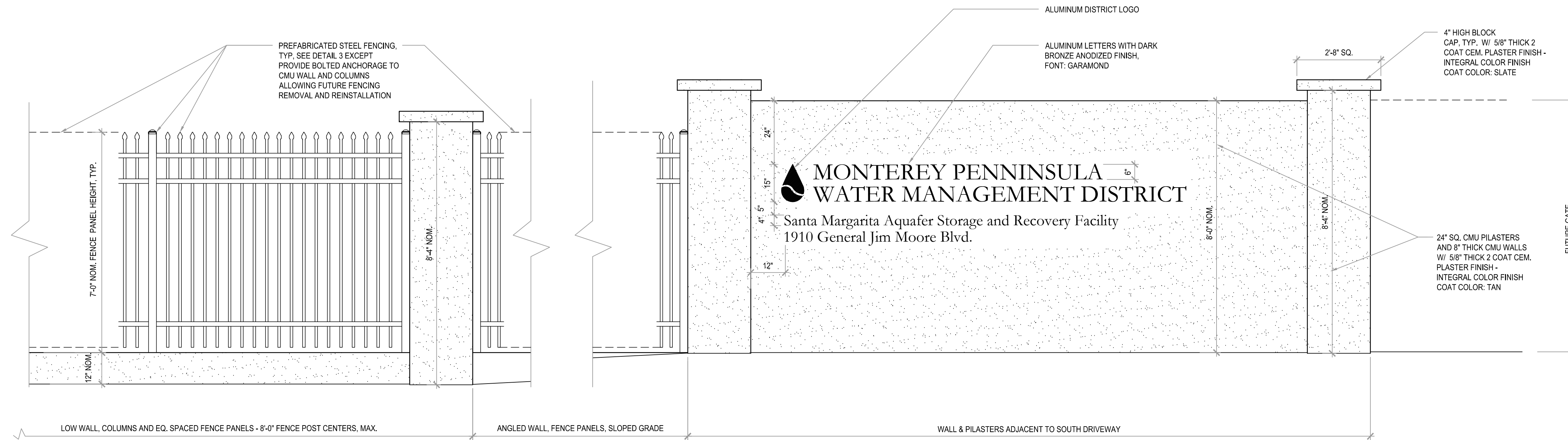

2 COLUMN @ FENCE PANELS
 SCALE: 1/2"=1'-0"

1 PILASTER / WALL @ DRIVEWAY
 SCALE: 1/2"=1'-0"

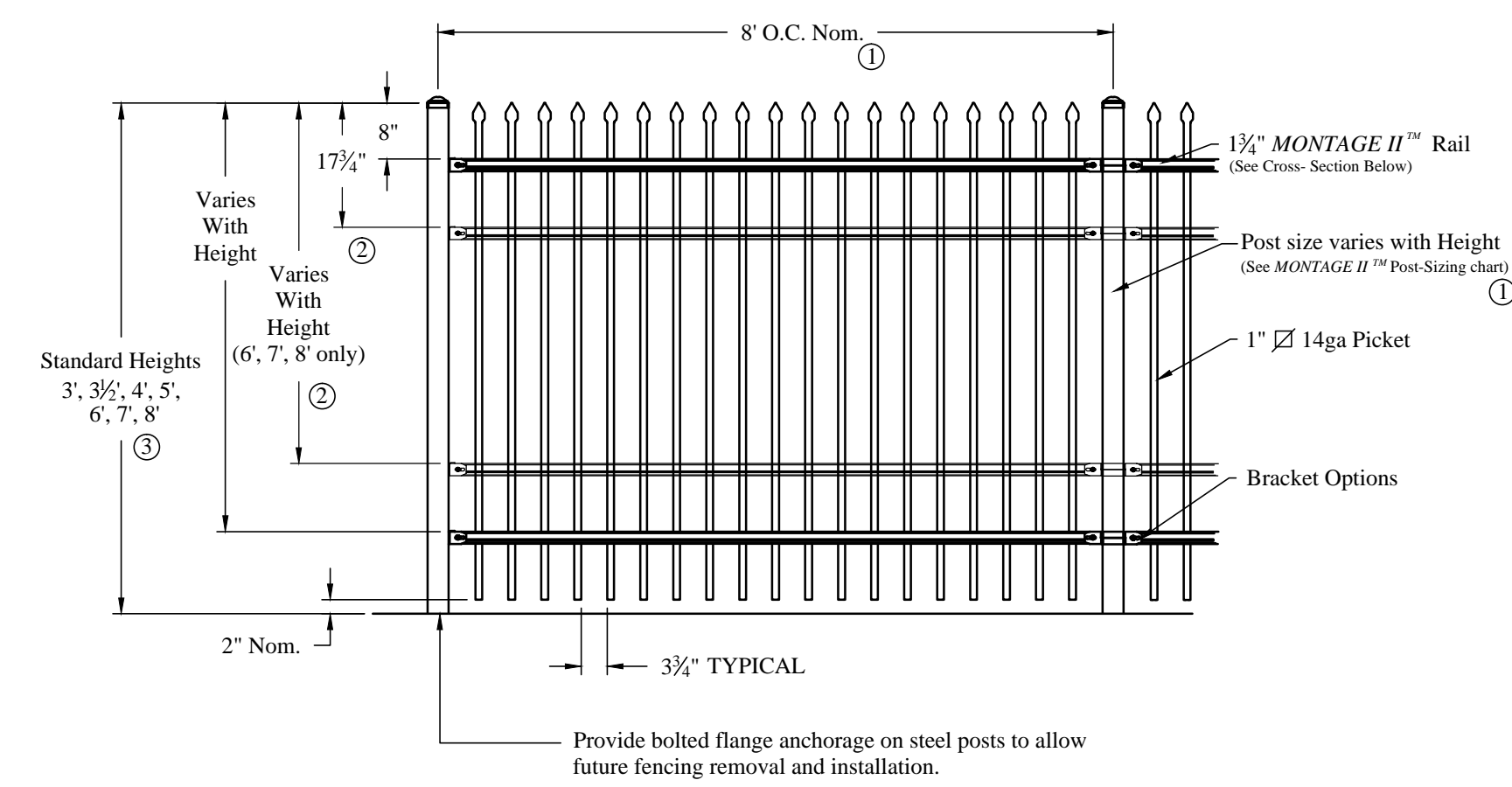
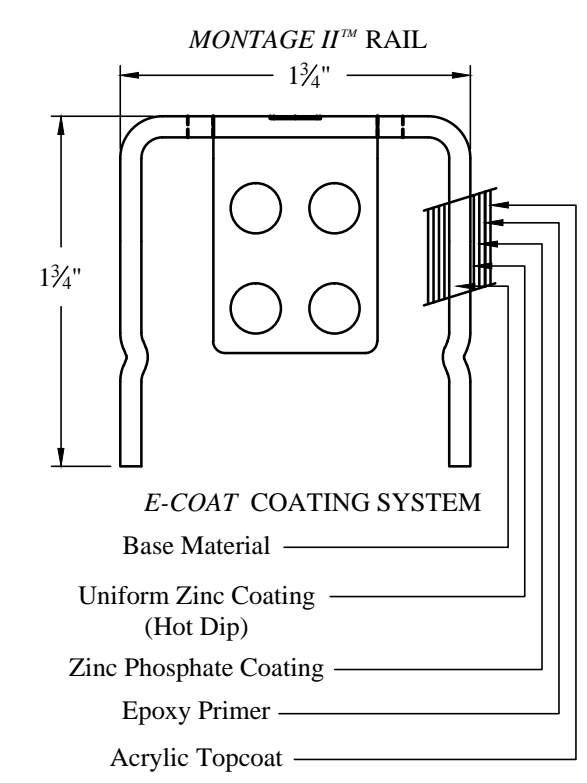

- NOTES:
 1.) Post size depends on fence height and wind loads. See MONTAGE II™ specifications for post sizing chart and setting dimensions.
 2.) Third & Forth rail optional.
 3.) Available in Flush Bottom.

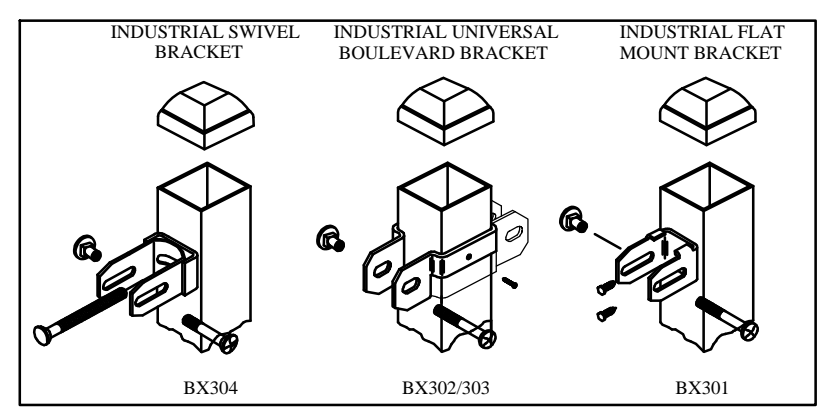

Values shown are nominal and not to be used for installation purposes. See product specification for installation requirements.

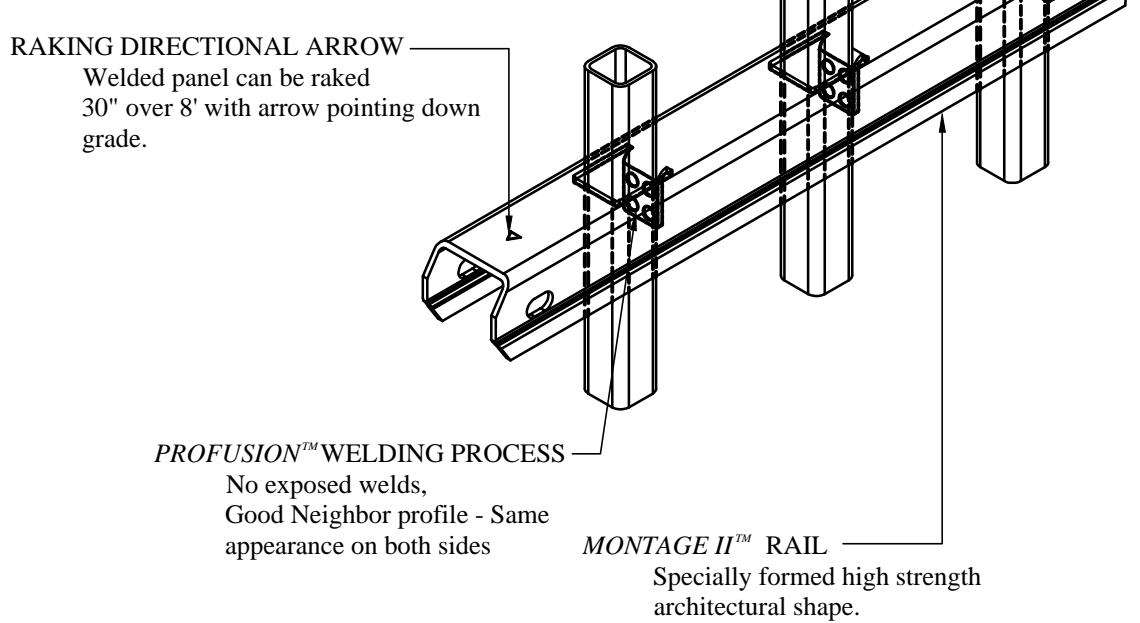

3 STEEL FENCE PANELS
 SCALE: NO SCALE

THE USE OF THE PLANS AND SPECIFICATIONS RESTRICTED TO THE ORIGINAL SITE FOR WHICH THEY WERE PREPARED, AND PUBLIC REPRODUCTION OR PUBLICATION OF ANY METHOD IN WHOLE OR IN PART IS PROHIBITED. TITLE TO THE PLANS AND SPECIFICATIONS REMAINS WITH THE ARCHITECT. VISUAL CONTACT WITH THESE PLANS CONSTITUTES PRIMA FACIE EVIDENCE OF ACCEPTANCE OF THESE RESTRICTIONS.